

## CCE 5220 – RF and Microwave System Design

### Tutorial 1: RF Basic Concepts & Performance Parameters

- (1) For the receiver in Figure 1, calculate:
- The noise figure of the system.
  - The overall gain of the system.
  - The minimum detectable signal at the input of the system.

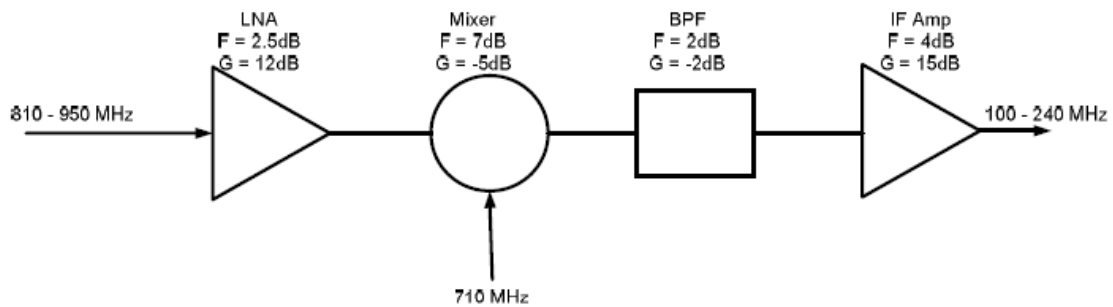

Figure 1

- (2) For the receiver in Figure 2, calculate:
- The noise figure of the system.
  - The overall gain of the system.
  - The minimum detectable signal at the input of the system.

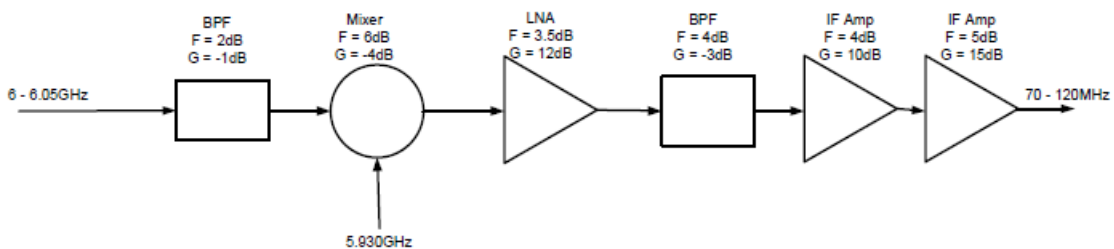

Figure 2

- If the output power at the 1-dB compression point of an amplifier, having a gain of 12 dB over a bandwidth of 1.2 MHz and a noise figure of 2.5 dB, is 10 mW, calculate the dynamic range of the system.
- The intercept point in the transfer characteristic of a nonlinear system is found to be 25 dBm. If a -5 dBm signal is applied to this system, find the intermodulation ratio.

- (5) A receiver operating at 900 MHz with its bandwidth at 1 MHz and noise figure at 16 dB. If its input impedance is  $50 \Omega$  and IP3 is 20 dBm, then find its dynamic range.
- (6) Discuss the following performance parameters:  
 (a) Minimum Detectible signal, (b) Gain compression, (c) Intermodulation Distortion Ratio, (d) Second-order harmonics, (e) Third-order intercept point, (f) Dynamic range
- (7) A nonlinear amplifier has transfer function:

$$v_{OUT} = 5v_{in} - 0.05v_{in}^2 - 0.1v_{in}^3,$$

a noise figure of 3 dB and a bandwidth of 100 MHz. If an input signal

$$v_{in} = 0.1 \cos(1.01 \times 10^6 t) + 0.08 \cos(1.012 \times 10^6 t)$$

is applied to this circuit, calculate:

- (a) The noise of the system.  
 (b) The gain compression.  
 (c) The intermodulation distortion ratio.  
 (d) The third-order intercept point.  
 (e) The dynamic range.
- (8) A  $250 \Omega$  load is to be matched with a  $50 \Omega$  line. Design (a) a resistive network, and (b) a reactive network to match the load. Discuss the performance of the two designs.
- (9) Analyze the heterodyne receiver architecture and compare it with the Image-reject receiver.