

Rural Malta: First Results of the Joint Belgo-Maltese Survey Project

Roald F. Docter, Nicholas C. Vella, Nathaniel Cutajar, Anthony Bonanno,
Anthony Pace

with contributions by Maxine Anastasi, Babette Bechtold, Morgan De Dapper, Alain De Wulf, Guy Dierkens, Soumaya Garsallah, Rudi Goossens, Boutheina Maraoui Telmini, Jihène Nacef, Timothy Nuttens, Xavier Ruiz i Cano, Mevrick Spiteri, Cornelis Stal, Winfred van de Put, Clive Vella, Lieven Verdonck, John Wood, Renata Zerafa

Abstract

The paper presents the first interdisciplinary results of a joint survey project in the north-west of Malta, with finds ranging from the Prehistoric till the Early Modern period. Three permanently inhabited sites were encountered dating to at least the late 6th or early 5th century BCE, with a clearer attestation in the Hellenistic/Roman and Late Antique periods. The resulting reconstructed settlement pattern of the Phoenician/Punic period suggests a managed landscape that seems to be a good reflexion of what is happening in North Africa and elsewhere in the central and western Mediterranean. At least from the Roman period on, these sites seem to have specialised on the production of olive oil.

INTRODUCTION

This paper presents the initial results of the Malta Survey Project.¹ It sets out the aims of the research, the design of the fieldwork, and the provisional results obtained during the first three campaigns (2008-2010). The Malta Survey Project (henceforth, MSP) is a trilateral endeavour of the Department of Archaeology of Ghent University (Belgium), the University of Malta and the Superintendence of Cultural Heritage (Malta). The scope of the MSP is very clear: it is an intensive, systematic field-walking survey in a kilometre-wide transect in the northwest of Malta, beyond the main Phoenician and Punic urban centre on the island, the present-day Rabat/Mdina (*fig. 1*).² The insular landscape is investigated diachronically, even though the MSP's principal interest lies in the Phoenician and Punic periods, that is to say from the late 8th century BCE until at least the period of the Roman occupation of the island, which started in 218 BCE. The particularity of the Maltese situation, as compared to other Phoenician/Punic landscapes in the central and western Mediterranean, is the fact that the main urban centre is not situated on the coast, but is located in the island's interior.³ This may have had an effect upon the way the rural landscape was seen, managed and exploited.

The project was conceived after a meeting that was held in Lisbon in 2005 as part of the 6th

International Congress of Phoenician and Punic Studies. One of the present authors (NCV) took part in a session where he spoke about the lack of data related to Punic rural sites on the Maltese archipelago.⁴ Phoenician and Punic Malta is largely, if not exclusively, known through the considerable number of tombs scattered all over the island;⁵ a lot is available about the distribution of Roman villas on the islands,⁶ but we hardly know anything about rural sites of the pre-Roman period.⁷ In fact, besides an unpublished intensive survey executed on the island of Gozo by an Anglo-Maltese team between 1988 and 1994, and a pilot survey project by a team of the University of Malta in the Xemxija area to the north of Malta in autumn of 2001 (NCV),⁸ the rural landscape of the Maltese islands has never received any systematic attention. In Lisbon, attention was drawn to this lacuna and its ramifications were considered, and in the aftermath a discussion about the subject was held with Roald Docter of Ghent University, who had just been awarded financial support from the Belgian Fund for Scientific Research Flanders in order to investigate the rural landscape of Punic Carthage. Unfortunately, that project got stuck in the Tunisian administrative system and fell through, with the result that in 2008 part of the funds earmarked for the Carthage project could be directed to Malta. The idea of a joint field-walking survey was brought up, a project that could be supported by sufficient funds and

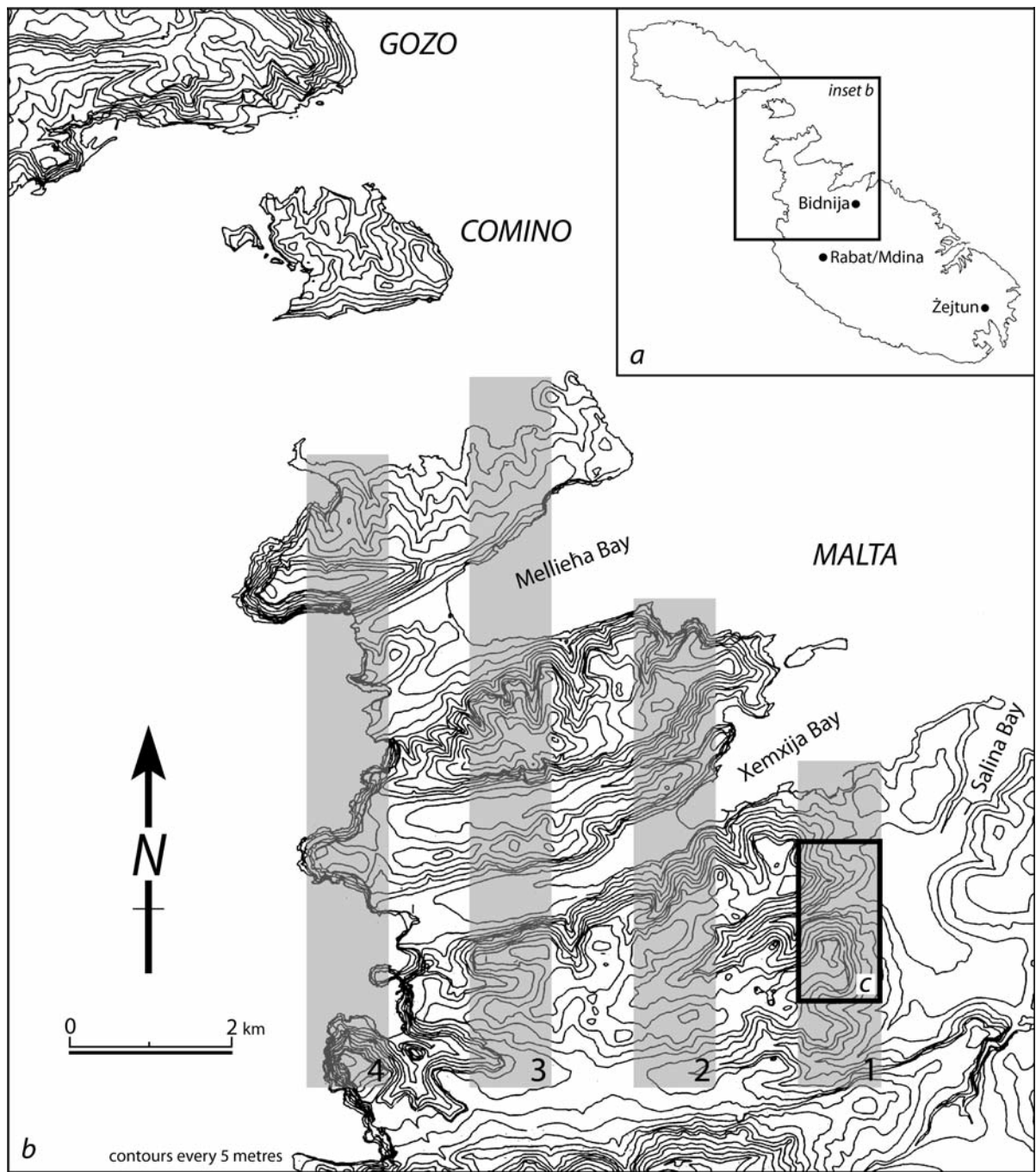

Fig. 1. Map of the Maltese islands with indication of the place names mentioned in the text (a), with inset of the location of the four transects (b), and inset showing the area surveyed in transect 1 (c), corresponding to figs 5-14 (map: MSP, drawn by MA).

backed by an international multi-disciplinary team of specialists. Preparatory work was conducted in Malta with the rest of the team from the Superintendence of Cultural Heritage (AP, NC)

and the University of Malta (AB), and a collaborative agreement covering the period 2008-2012 was drawn up and signed.

RFD, NCV, NC, AB, AP

AIMS

The Malta Survey Project was designed to accomplish three aims:

1. understand the exploitation of an island landscape over the long-term, using different techniques, starting with a geomorphological study, a systematic field-walking survey, geophysical prospection, and excavation if the opportunity arises, with an overall emphasis on the Phoenician/Punic period;
2. create a reference collection of diagnostic sherds and fabrics, which are period-specific in order to facilitate the identification of abraded sherds picked up during the survey;
3. provide undergraduate and graduate students with training in field-walking methods and techniques as well as finds processing, and encourage the sort of interaction between students and specialists that often results in interesting observations and original insights.

RFD, NCV, NC, AB, AP

FIELDWORK DESIGN

The designated area for survey was decided upon after serious deliberation. Initially we had in mind a survey in two areas of the Maltese Islands, one in the South (around Żejtun where the University of Malta had an on-going project at a Roman villa site) and one in the North (beyond Mdina/Rabat) (*fig. 1*). After discussions during a field visit in June 2008 with the geomorphologist, Morgan De Dapper of Ghent University, it was decided that the northern part of Malta would offer us the opportunity of running a series of transects across

different topographic features - including valley slopes, basin, ridge, coastal zone - which characterise the area to the north of the Great Fault (Victoria Lines; *figs 1-2*).⁹ It had the further advantage that it appeared to be a relatively undisturbed 'agro-landscape'.¹⁰ Moreover, in the belief that any study about the mutability of the Maltese landscape is better informed by documentary sources,¹¹ we wanted to concentrate our efforts in an area for which archival material (consisting essentially of property books - *cabrei* - and related papers) was known to be readily available. Of the four, kilometre-wide transects drawn randomly on a map, we decided to opt for the first one, running northwards from the Victoria Lines, crossing the village of Bidnija. Here the terrain appeared to be accessible to field-walking, with no high walls blocking access to fields. Moreover, the Mdina Cathedral had one of its largest territorial possessions - the territory of Ghajn Riĥana - in this area, as readily attested by the 1783 territorial marker built into one of the farmhouses at Bidnija.¹²

The survey took place in the area of Bidnija, 5 km to the north of Rabat/Mdina (*fig. 1*), each year during the end of August and the beginning of September, when some fields had just been ploughed or others were still fallow after the spring harvest (*figs. 2, 8*). The field-walking method is quite straightforward and follows tried and tested recovery practices applied elsewhere in the Mediterranean over the last decades.¹³ In fact, the survey set-up had initially been conceived on the basis of the Ghent-based Potenza Survey Valley Project (Italy), but was adapted to the landscape realities of Malta.¹⁴ Instead of setting up a grid to



Fig. 2. Typical landscape from the Victoria Lines to the north. In the background at the left is the village and church of Bidnija, in the centre the modern town of Buġibba/Qawra with Salina Bay to the right (photograph: MSP, by RFD, 28.8.2009).

demarcate tracts as is sometimes done in surveys, walking in Malta could be carried out within plots of land defined by field boundary walls or terrace walls; these constituted the tracts or collection units. Surface visibility was overall very good but overgrowth in abandoned fields and below ridge escarpments made field-walking difficult and sometimes impeded visibility (*fig. 7*). Two teams of walkers were assigned two separate areas during each campaign, and walker spacing was standardized to 10 metres, a distance which is considered a safe option where inexperienced field-walkers are involved. We collected only what one could see while walking along the line without making any selection of finds in the field. This translates into an area of about a metre to either side. In this manner, an area of 20% within each tract (and within the transect) was sampled and all archaeological material - consisting mostly of pottery sherds but also worked stone, tile, marble, plaster, glass, bone, pebbles and sea shells - was retrieved. Given the limited sizes of most tracts, concentrations of finds could not always be collected separately; in most of these cases the tract as a whole may be considered as a concentration. In those cases where in the field or after finds processing the existence of a site was suspected, additional intensive survey took place in the form of a 'block survey' in grids of 10 x 10 metres. In each grid, two persons collected all the pottery and other artefacts they could in five minutes. These sites were also geophysically investigated with a Ground Penetrating Radar (LV). Data collection was noted in tract record forms, adapted from tried and tested versions, designed to integrate topographic, geological and field-use information with other data related to structural features that may be present within tracts, either natural ones (e.g. caves), built (e.g. apiary huts, bird trapping hides, farmhouses, corbelled huts, threshing floors) or even rock-cut (e.g. tombs, cart-ruts).

Given the size of the island of Malta (ca 245 square kilometres), the total surface that will be covered by the survey at the end of the project amounting to ca 5 square kilometres, though small in itself, gives a fairly representative coverage of 2% of the island. The project was designed to be very intensive and backed by a very detailed study of the finds. The philosophy behind the survey may, hence, be summarised as 'small is beautiful' but the results may be considered to be fairly representative of the archaeology of the Maltese landscape.

RFD, NCV, NC, AB, AP, MDD, MA, MS, LV

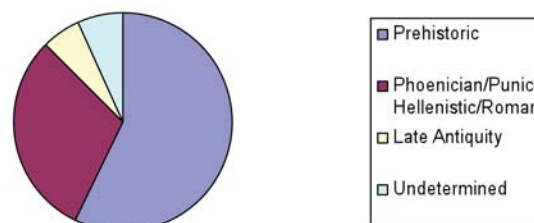

Fig. 3. Chronological division of the archaeological sites recorded from north-west Malta (N=388; diagram prepared by MS).

INVENTORY OF ARCHAEOLOGICAL SITES IN NORTH-WEST MALTA

In 2008, initial studies as part of the Malta Survey Project involved the compilation of an inventory of archaeological sites found in the north-west of Malta. Such a compilation of known archaeological data aims at placing the results attained during the field walking survey in a broader archaeological context. A total of 308 data sheets including Prehistoric, Phoenician/Punic, Hellenistic/Roman and Late Antique archaeological sites were inventoried. A division of these data by period shows that 222 sites belong to Prehistoric times, 117 sites belong to the Phoenician/Punic and Hellenistic/Roman times and 23 sites belong to Late Antiquity. A total of 26 archaeological sites are yet not determined to any period (*fig. 3*).

This desktop study involved an in-depth research where all the known data reported in various bibliographical sources since at least the 1860s were captured onto data sheets designed for the project's inventory. The bibliography includes primary sources reporting archaeological discoveries and observations as well as interventions carried out. These sources include the Museum Annual Reports (M.A.R.), the Archaeological Field Notes of T. Zammit and also other descriptive writings by G.A. Ciantar (1772), J.S. Swann (1866) and A. Mayr (1905). Other detailed studies, such as the preliminary archaeological reports of the Missione Archeologica Italiana (1963-1970) on the San Pawl Milqi villa site as well as the survey of prehistoric antiquities by J.D. Evans (1971), the survey of catacombs by M. Buhagiar (1986), and the survey of Punic antiquities by C. Sagona (2002), were all central to the compilation of this inventory.

The data compiled for this inventory were recorded on Data Capture Sheets. Each data sheet relates to a single archaeological site, which may consist of various archaeological remains, and includes details about its location, the history of

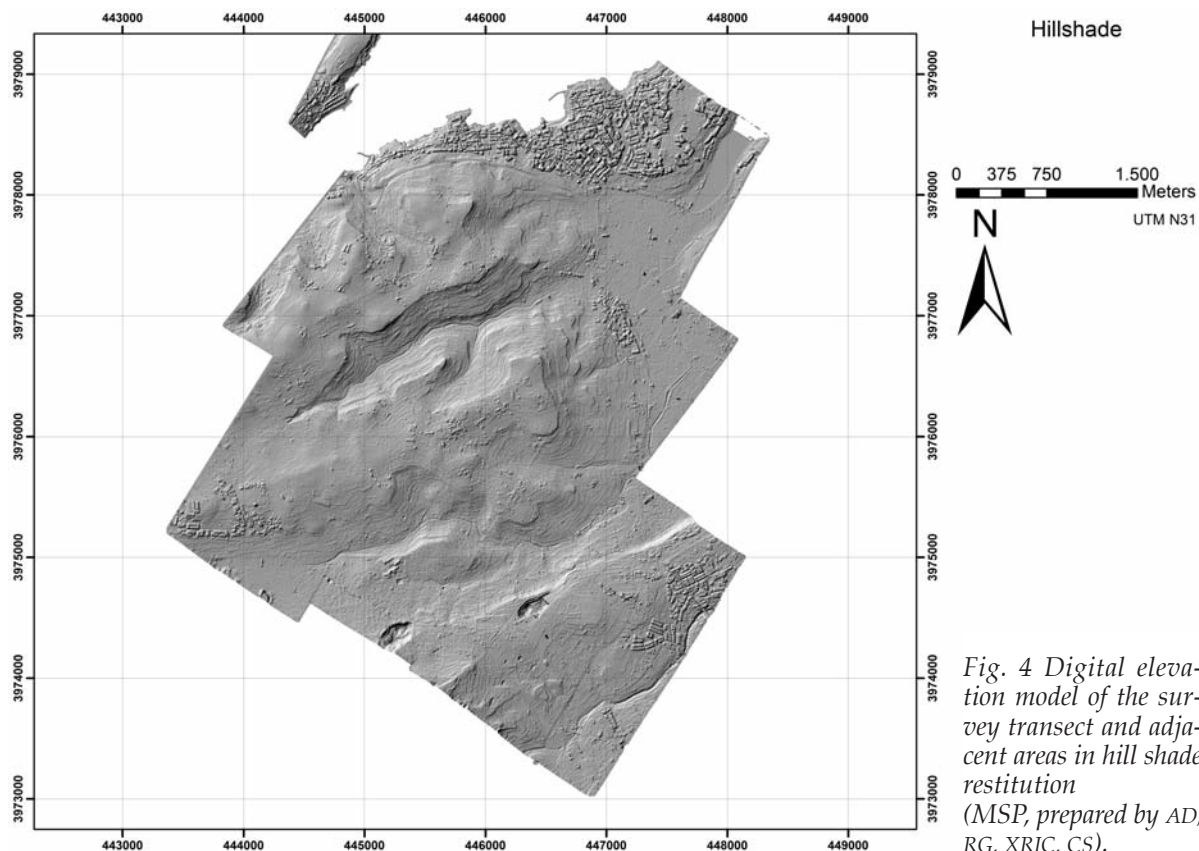

Fig. 4 Digital elevation model of the survey transect and adjacent areas in hill shade restitution (MSP, prepared by AD, RG, XRIC, CS).

archaeological interventions, a description and date, the landscape setting, and bibliographic sources.

The information gathered during this initial phase of the project will be integrated with the results attained from field walking and mapped onto GIS for further studies. Moreover, this inventory of archaeological sites will contribute to the populating of the National Cultural Heritage Inventory Management System (CHIMS).

MS

TOPOGRAPHICAL SURVEY AND DIGITAL ELEVATION MODEL¹⁵

In 2008, a small team of topographers (AD, TN) joined the survey to measure the several features encountered during the field walking process. They were aided in the field by a Maltese archaeology student (RZ). It was decided to focus upon the area of the garigue plateau of the Ġebel Ghawżara site and adjacent areas, because it would constitute the single largest more or less undisturbed and accessible garigue plateau within the 5km² territory covered by the survey.¹⁶ The topo-

graphical measurements were taken with a total station (Trimble S6 Robotic Total Station) and GPS (GNSS) measurements. The accuracy of the angle measurement of the Trimble S6 used for this project is up to 2" and the accuracy of the distance measurement in standard mode is about 3 mm + 2 ppm or in tracking mode about 10 mm + 2 ppm. Features recorded include tombs, edges of quarries, walls and cart-ruts.

Between 2008 and 2010, several Phoenician/Punic, Hellenistic, Roman, Late Antique and Medieval sites and features have been documented within the survey area. In order to facilitate the spatial analysis of these, it was deemed essential to have an orthophoto plan and a digital elevation model (DEM), covering the full survey area and its adjacent landscape. The use of such geo-data has been advantageous in other recent archaeological projects of Ghent University.¹⁷ Therefore, an orthophoto plan and DEM with an accuracy of 25 cm of an area of ca 20 km² in the north-western part of Malta has been constructed by the Geomatics Department of Ghent University.

Since no data with the desired quality (better than 5 meters) had been available for this area,

the orthophoto plan and DEM had to be computed based on a set of 69 reference points in the field, needed for geo-referencing. With a resolution of 25 cm, an accuracy criterion of 0.5 to 2 pixels, or 12.5 cm to 50 cm, should be taken into account for each measured reference point.¹⁸ The 69 points were measured in a one-week field campaign in November 2009 by a small team (ADW, RG, RFD, XRIC) employing a global navigation system (GNSS) using differential correction signals of the StarFire augmentation system. Using the C-NAV 2050 GPS module and 5 minutes of initialization, the accuracy criterion could be respected.¹⁹

The final joined DEM for the whole area (fig. 4) is based on nine photogrammetric stereo couples, with a scale of 1:10,000 and a resolution of 25 cm.²⁰ These stereo couples were processed using the photogrammetric software *VirtuoZo*TM.²¹ The quality analysis of the DEM, based on overlapping zones between different orthophotos, is executed by the point processing software *WinTopo*. Based on this analysis, an altimetric error of 1 metre is calculated within the 50% 'circular error probable' (CEP) and an error of 2 meters within the 76.2% CEP. The arithmetic mean error of the altimetry is 28 cm. Different derivative products from the orthophoto plan and DEM - like contour line maps, 3D models, hill-shade maps and others - will serve to analyse further the sites and archaeological features in this part of Malta.

AD, RG, XRIC, TN, CS, RZ

FINDS AND REGISTRATION

The field survey carried out in 2008, 2009 and 2010 yielded 40,696 finds, consisting mainly of pottery fragments. This is a remarkably high number considering the fact that actual survey on the terrain lasted only 33 working days with two teams of between 8 and 10 persons each. Moreover, such high numbers were not expected given the fact that initial interviews with Maltese farmers gave the impression that pot sherds had often been collected from the fields on a regular basis to be used in the production of *deffun* - a thin waterproof mortar consisting of crushed potsherds mixed with lime applied to flat roofs, a practice that has also been documented in a note published early last century; apparently there was a marked preference for prehistoric potsherds for such a task.²² It should be stated here, that during the survey no preliminary selection was made in the field. All finds picked up during the field walking were brought to the finds' laboratory, where they were washed, counted, bagged and registered in a pre-

liminary manner by the field walking teams.

The collected and counted finds were already during the survey campaigns subject to detailed inventorying operations in the finds' laboratory by several ceramics specialists (*WvdP, MA, RFD, BMT, JN, SG, NC*). Every individual pottery fragment was clipped in order to get a fresh break for detailed fabric study with the aid of magnifying glasses (8 or 10x). Apart from their own expertise on which each individual specialist could rely, a reference collection of the most common fabrics encountered during the survey was created for comparative purposes. By this procedure, a first basic classification could be made of all finds, both of the diagnostic and the 'undiagnostic' finds such as wall fragments. Great effort was taken to distinguish different fabrics within the large body of ceramic finds, especially of the local productions.²³ The study of the largely Punic necropolis material by Sagona had established a fabric typology, but in this case the scholar had to operate under the constraints of a museum collection consisting mostly of near-complete or intact vessels.²⁴ Her fabric typology, therefore, was not based on the study of fresh breaks, but on observations made of the surface of the fabric. The results have a rather limited value and in fact were often difficult to corroborate with the survey material discussed here.

Each find was registered in the database, initially on an EXCEL spread-sheet, with detailed information on the following parameters: survey tract number, pass, feature, wall or concentration number, individual number (if assigned for further study), condition (good, medium, poor), object shape, status (wall, base, rim, handle, etc.), ware (plain, red slip, glazed, etc.), type (if already known), type of non-ceramic find (if applicable: iron, glass, bone, shell, etc.), general date, number of fragments, provenance (local, import or as specific as possible: North Africa, Campania, etc.), additional comments, and the initials of the specialist who made the description. In order to cope with the inevitable backlog ensuing from the detailed study and registration of all the finds, several separate study campaigns were organised. The result is that at present 29,309 finds have been entered in the finds database (i.e. 72%). In Spring 2012 a study campaign is expected to cope with the remaining backlog from the last campaign.

RFD, NCV, NC, MA, BB, GD, SG, BMT, JN, WvdP

CHRONOLOGY

The fact that the survey is investigating human interaction with the landscape diachronically implies the recovery of material remains encompassing an extremely wide chronological range. We started off our work making use of existing chronologies but we decided to fine-tune these as work progressed for several reasons. For instance, in her study of (Phoenician/)Punic antiquities, Sagona established a general, but refined chronological framework for the Phoenician/Punic period, based upon the pottery encountered in the Maltese tomb groups.²⁵ In view of the fact that the extremely fragmented and often very abraded pottery found in the survey may only rarely be compared to the pottery types defined by Sagona, and hence to her phases, it was decided not to use her chronology for the Iron Age, but to work out the following general dating scheme for the survey. In the case of the Phoenician/Punic and Hellenistic periods, we refer to the dating scheme worked out for Carthage in the column 'Definition' of the table below.²⁶

A very pertinent question relates to the apparent overlap between two chronologies: that of the 'Late Punic' period in use for the material culture of Carthage and the rest of the Central Mediterranean and of the 'Roman' or 'Roman Republican'

period used for Malta. After the Romans captured the Carthaginian garrison that guarded Malta in 218 BCE at the start of the Second Punic War and effectively took possession of the Maltese islands, these soon became included in the administration of the Roman province of Sicily. The material culture of Malta and its population, however, may initially at least not have differed much from that of the Late Punic world to which it culturally was still connected. This seems to hold especially for the first half of the 2nd century BCE, during which the Maltese islands would have been open to influences from both the prosperous metropolis of Carthage and its North African territories and the West Sicilian territory, where the population had retained most of its Punic character under Roman administrative domination.²⁷ Since also for Carthage, this period is often referred to as the 'Hellenistic phase', we have chosen to use this more neutral term for this period.

Also with regard to the periods 'Late Antiquity' and 'Early Medieval' the realities of the archaeological record have been the defining factor rather than the historical data. Historically, one would otherwise have considered the passage of Belisarius in Malta in 533 CE as the start of the Byzantine period, and equally the year 870 CE (conquest of Malta) as the start of the Arab period.²⁸

RFD, NCV, NC, AB, AP, MA, BB

Period	Absolute chronology	Definition	Sagona 2002, 2008
Prehistoric	Till mid-8 th century BCE	Prehistoric/Bronze Age	Archaic Phase I (ca 1000-750 BCE)
Phoenician/Punic	Mid-8 th -3 rd century BCE	Phoenician/Early Punic-Late Punic I	Established Phase I (750-620 BCE)
			Late Phase I to Early Phase II (620-600 BCE)
			Phase II (600-500 BCE)
			(Early) Phase III (500-410 BCE)
			Late Phase III to Early Phase IV (410-218 BCE) ²⁹
Hellenistic	2 nd -1 st century BCE	Late Punic II-Early Roman	Phase IV (218-100 BCE)
			Phase V (100 BCE-ca 50 CE)
Roman	1 st -3 rd century CE	Roman Imperial	Phase VI (ca 50 CE onwards)
Late Antiquity	4 th -7 th century CE	Late Roman-Early Byzantine	
Early Medieval	8 th -early 10 th century CE	Late Byzantine-Early Arab	
High Medieval	Late 10 th -early 13 th century CE	Late Arab-Norman	
Late Medieval	Late 13 th -early 16 th century CE	Aragonese-Renaissance	
Early Modern	Late 16 th -20 th century CE	Knights-British Colonial	
Recent	20 th century CE		

FINDS DENSITIES AND DISTRIBUTION

As the Malta Survey Project is still on-going, fig. 5 shows the status of field-walking and finds processing at the end of the 2010 campaign. Field-walking occurs systematically: the transect is covered as completely as possible in its entire width (1 km) in passes of 10 m distance, except for tracts which are not accessible for field-walking because of excessive overgrowth or because access is not

allowed by the owner (tracts shown in red). For the tracts marked in yellow, field-walking took place but finds have not, or only partially, been processed so far. For those tracts marked in green, detailed results from finds processing are available, and some of these are presented in figs 9-14.

The overall finds density map (fig. 6) includes all types of objects: pottery, ceramic and non-ceramic building material, drainage pipes, lithic artefacts, pebbles, bones, glass, metal objects, fossils,

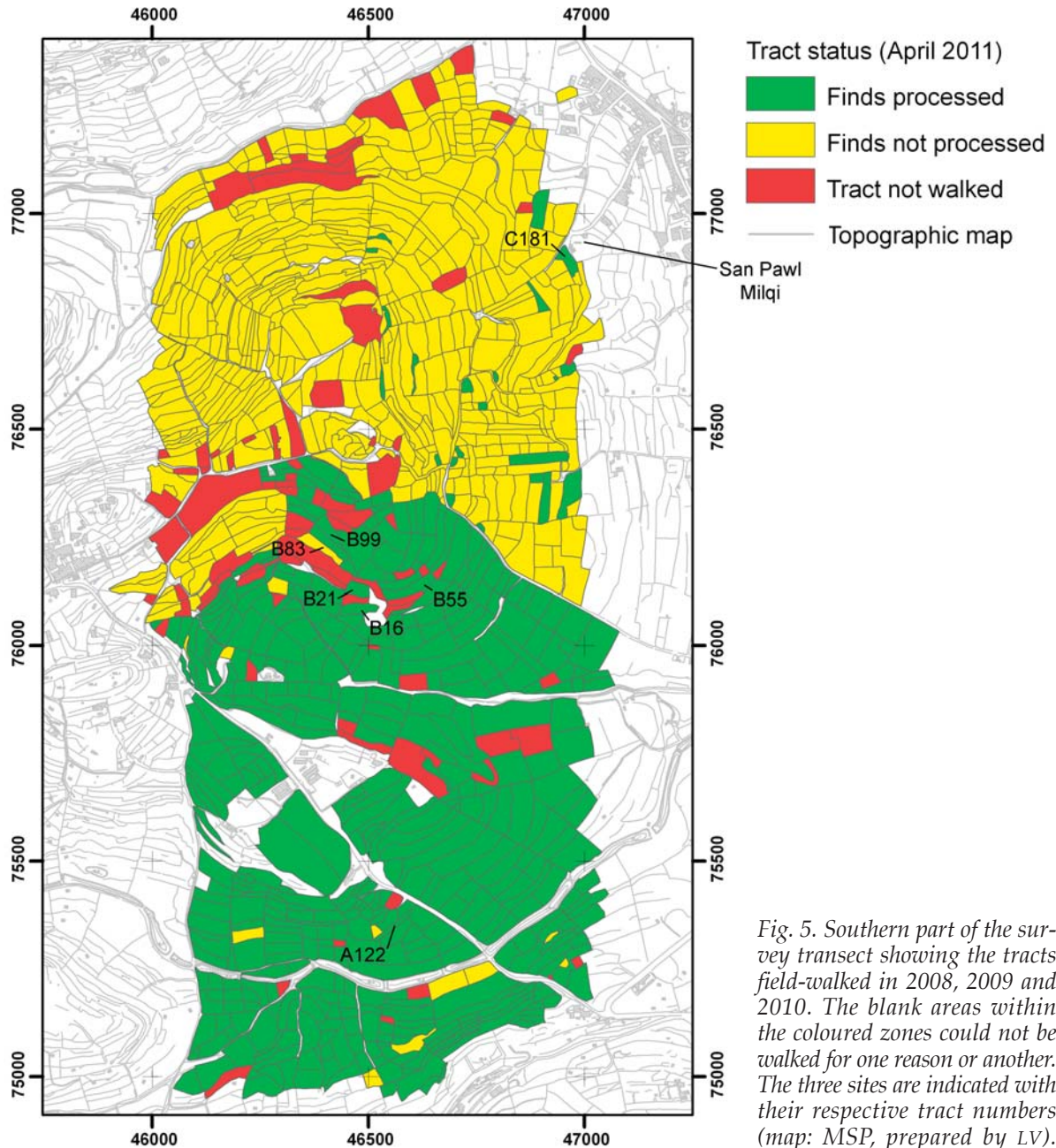

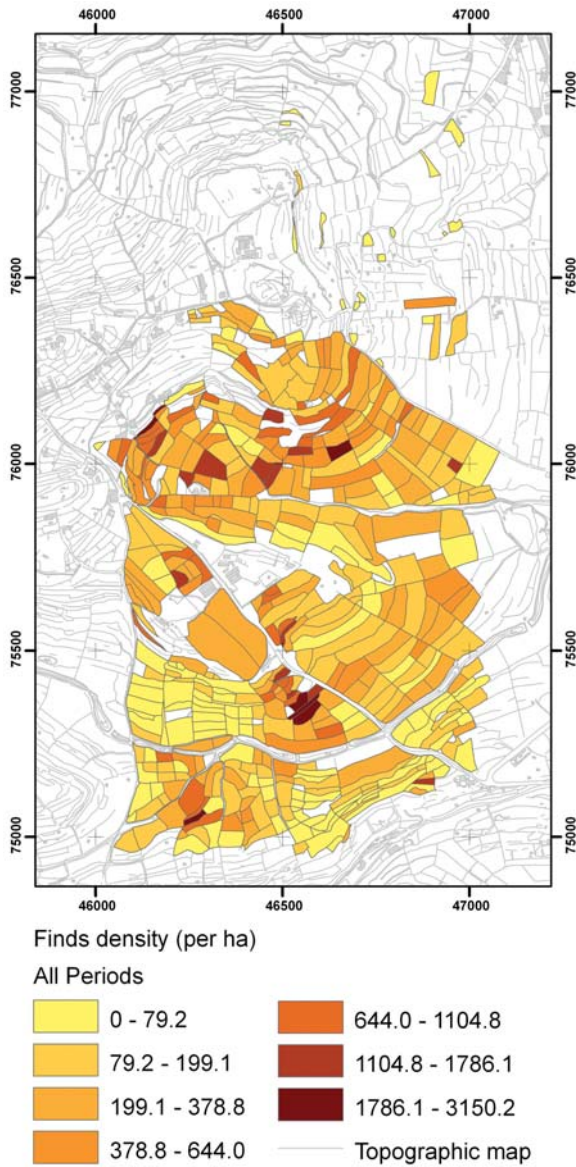

Fig. 6. Finds density (per ha), based upon all material studied and entered in the database of the campaigns 2008-2010 (map: MSP, prepared by LV).

stones, shells and undefined artefacts. Specific maps per period are based on datable finds only (figs 9-14). Often, it proved impossible to assign a precise date to pottery or other artefacts, as when an object was dated from the Hellenistic period to Late Antiquity. The dating of these objects was therefore considered as undetermined, and they were not included in the maps related to one specific period. The distribution maps take account of all finds collected on the passes of the surveyed

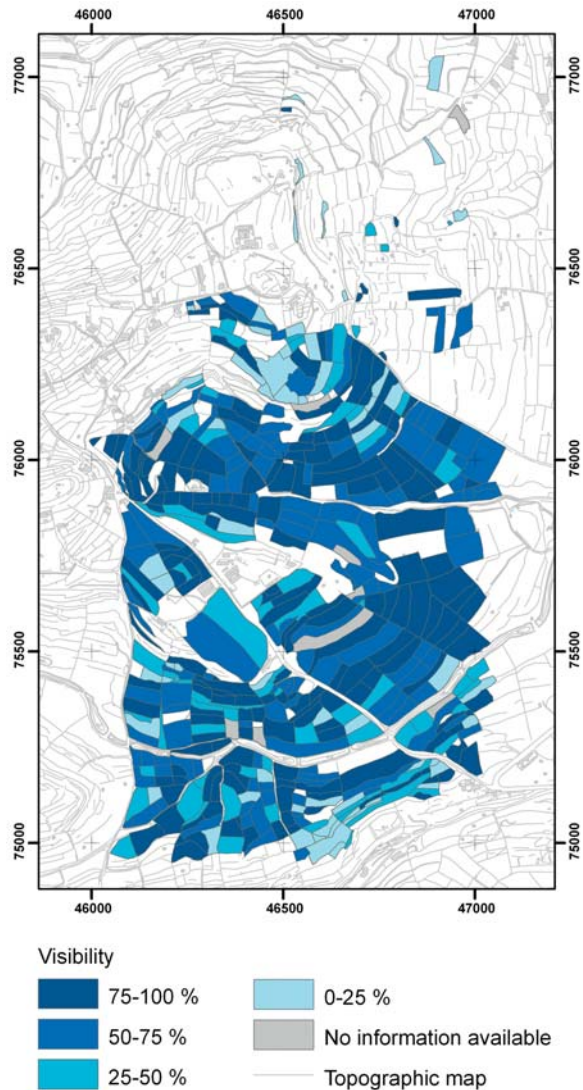
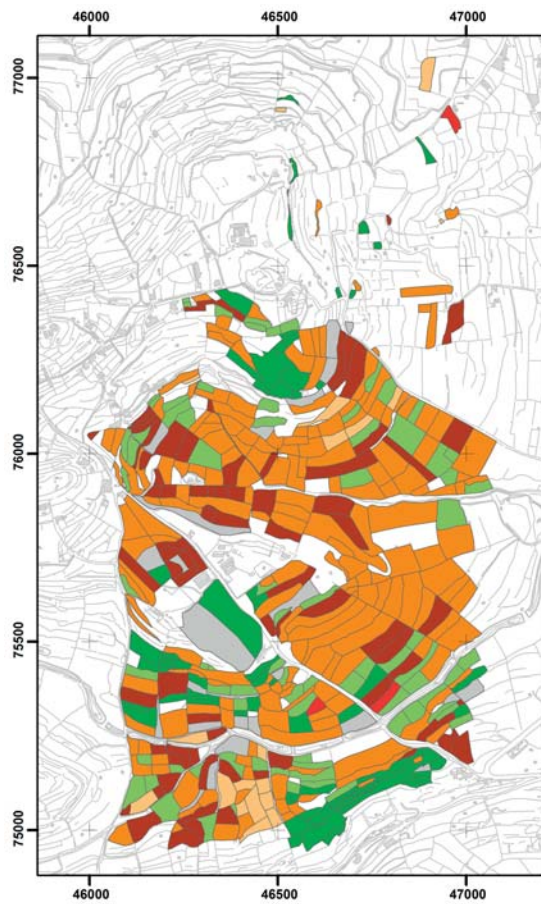

Fig. 7. Visibility of all tracts of which the finds have been studied and entered in the database of the campaigns 2008-2010 (map: MSP, prepared by LV).

tracts, but for reasons of comparability do not include the finds separately collected on (suspected) sites during a 'block survey' (see above).

The finds' quantities were normalized by means of the tract area (densities are given per ha). For each quantity, seven classes were created using the natural breaks function in ESRI ArcGIS 9. Visibility conditions, land use and other factors were different throughout the prospection area. Densities have not been corrected for these dif-



Land Use

- Arable land, fallow
- Arable land, ploughed
- Arable land, sown
- Arable land, abandoned/wasteland
- Horticulture
- Built up area
- Other land use/undetermined
- Topographic map

Fig. 8. Land use of all tracts of which the finds have been studied and entered in the database of the campaigns 2008-2010 (map: MSP, prepared by LV).

ferent field-walking circumstances, but visibility and land use are shown in figs 7-8.³⁰

The picture emerging from the finds distribution of the Phoenician/Punic period (fig. 9) shows a fairly good coverage of the landscape with a tendency to cluster on the terraces just below the

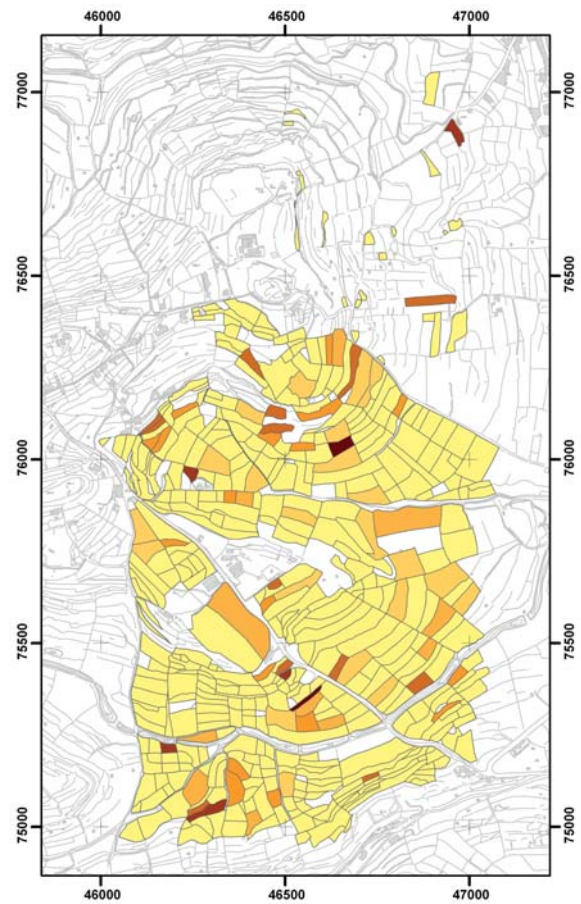

Finds density (per ha)

Phoenician/Punic

- | | |
|---|---|
| 0 - 1.2 | 10.2 - 16.8 |
| 1.2 - 3.9 | 16.8 - 34.9 |
| 3.9 - 6.3 | 34.9 - 94.1 |
| 6.3 - 10.2 | Topographic map |

Fig. 9. Phoenician/Punic period: finds density (per ha), based upon all material studied and entered in the database of the campaigns 2008-2010 (map: MSP, prepared by LV).

garigue escarpments. The planned collocation of these data with the Digital Elevation Model (see above, fig. 4) may highlight this tendency even better. For the Hellenistic/Roman period, the distribution pattern that focuses upon terraces below the escarpments is extremely clear (fig. 10). Especially when extracting the distribution data of ceramic and non-ceramic building material of that period (fig. 11), it is clear that we are dealing with

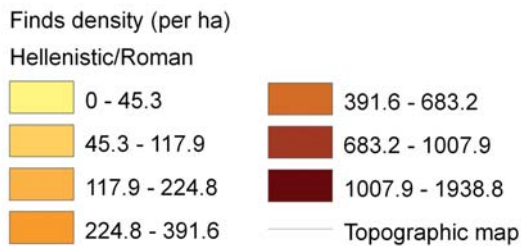
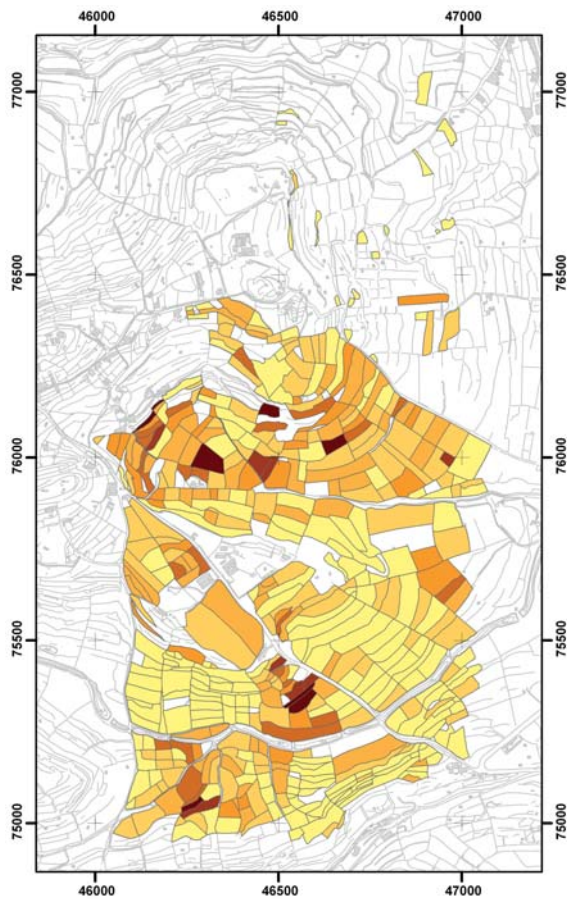

Fig. 10. Hellenistic/Roman period: finds density (per ha), based upon all material studied and entered in the database of the campaigns 2008-2010 (map: MSP, prepared by LV).

two clusters of inhabited sites within the survey area of which the finds have been intensively studied (see below for the characterization of these sites). A cluster in the south-western part of the survey transect (fig. 9), already emerging in the Phoenician/Punic period (fig. 10), is either a site of a less permanent character, in view of the absence of building material (fig. 11) or the result of a recent dump of material brought in from else-

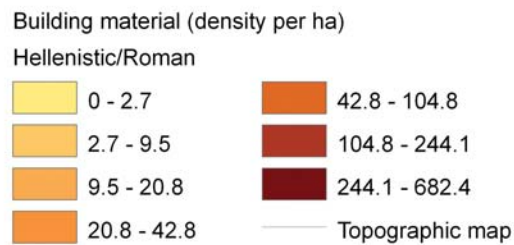
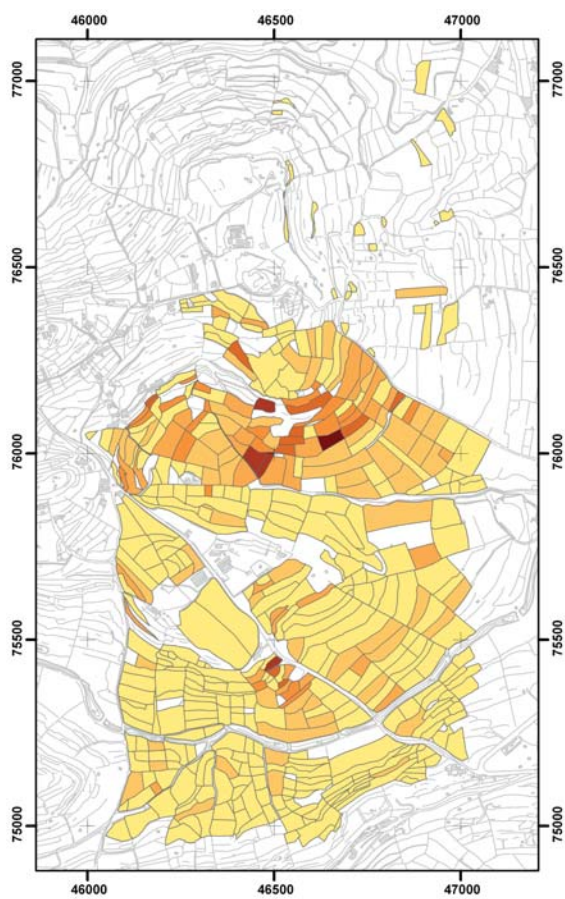

Fig. 11. Building material of the Hellenistic/Roman period: finds density (per ha), based upon all material studied and entered in the database of the campaigns 2008-2010 (map: MSP, prepared by LV).

where on Malta and containing earlier material.³¹ For the Late Antique period (fig. 12) it seems that the finds densities continue along the lines set out in the Phoenician/Punic period, but in the western part of the survey an offspring of the central site within the transect seems to pop up. This is exactly the area where the present town of Bidnija is situated. This emerging site seems to continue into the following Early Medieval (fig. 13) and

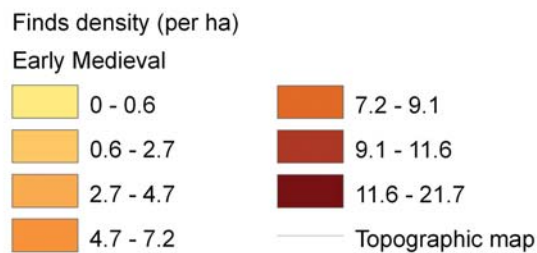
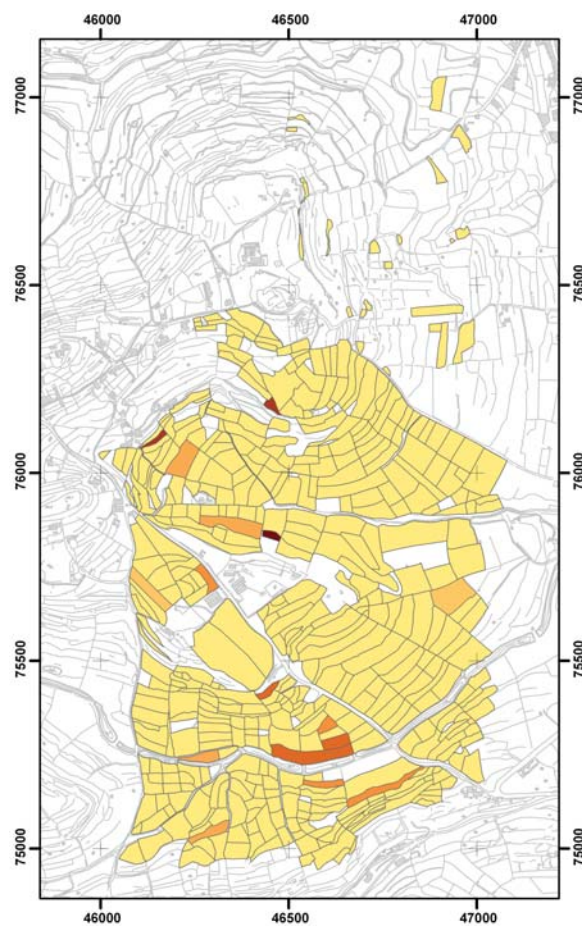
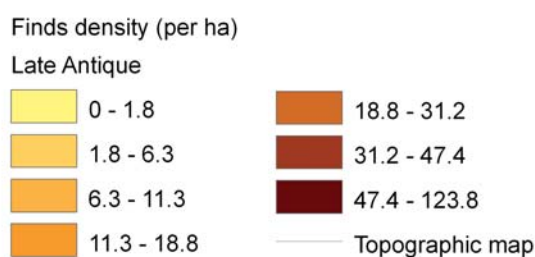
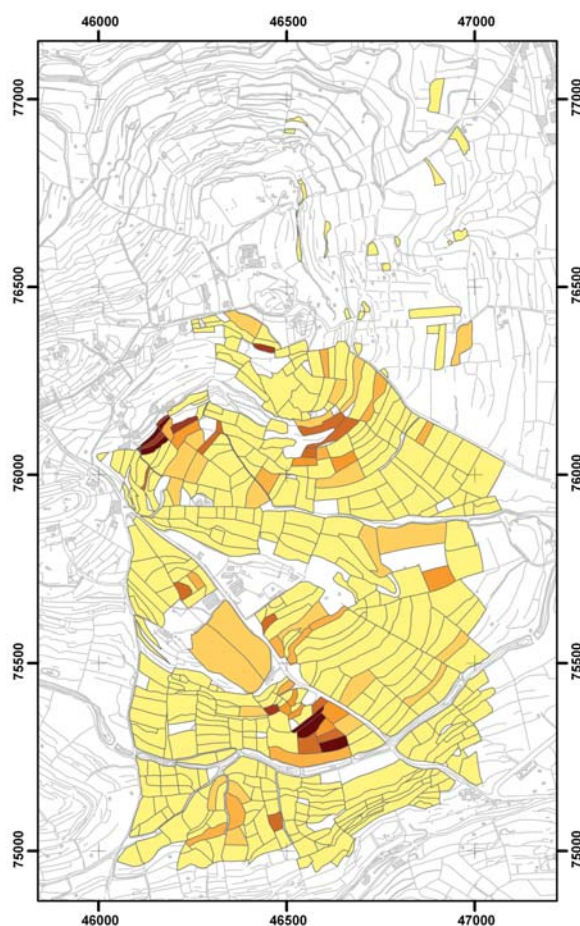

Fig. 12. Late Antique period: finds density (per ha), based upon all material studied and entered in the database of the campaigns 2008-2010 (map: MSP, prepared by LV).

Fig. 13. Early Medieval period: finds density (per ha), based upon all material studied and entered in the database of the campaigns 2008-2010 (map: MSP, prepared by LV).

High Medieval period (fig. 14), whereas the finds densities on the main central site seems to thin out.

LV, NCV, RFD, NC

SITE IDENTIFICATION AND CHARACTERIZATION

In the context of the present preliminary contribution we will limit our discussion to sites of the

1st millennium BCE, since a clear distinction of 'sites' of other periods may only be feasible after the whole survey transect has been covered and the finds of all tracts have been studied in detail (see above). Within the transect, three clear sites dating to the Phoenician/Punic period till at least Late Antiquity were identified and could be (re-) explored: Gebel Ghawzara (pronounced Jebel

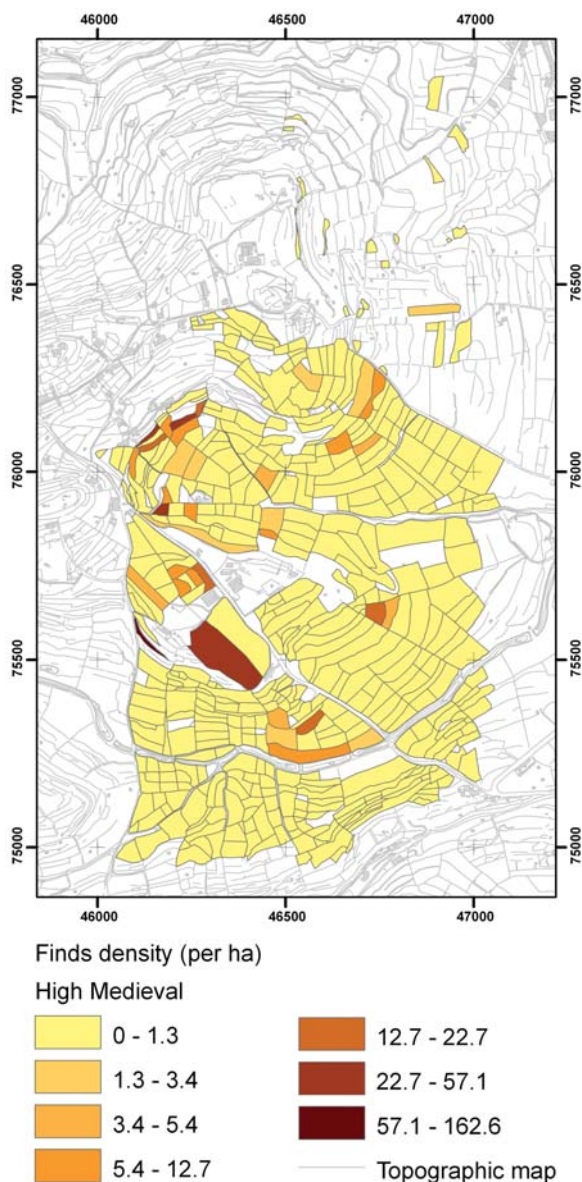

Fig. 14. High Medieval period: finds density (per ha), based upon all material studied and entered in the database of the campaigns 2008-2010 (map: MSP, prepared by LV).

Awzaara), Tal-Għazzi (pronounced Tal-Aatsi), and San Pawl Milqi (see fig. 5).³²

The first site (Gebel Ghawżara), in fact, consists of several contiguous tracts. The site is centred round an area with an old olive grove and an extensive bamboo bush which is indicative of a water source, already shown in an 1838 cadastral map of the area (fig. 5).³³ The site has been known to

be the location of a farmstead, probably of Roman date, for a long time. In 1911 or 1912, stone troughs and fragments of an olive pipper (or *trapetum*) were found here.³⁴ In the brief report of the discovery, it was noted that ‘the whole place deserves further study as traces of foundation walls are visible and potsherds are plentiful in the vicinity’, but the site was left unexplored.³⁵ Sometime in the mid-1970s one of the present authors (AB) accompanied the professor of Latin at the University and monsignor of the Mdina Cathedral, Rev. Edward Coleiro, to the area when farmers reported that a mechanized rotary soil tiller fell into a large hole where large blocks of stone (one of which with painted plaster) could be seen about 40 cm below the surface.

The pottery collected on tract B21 during the survey is predominantly of Roman date but the site must have a pre-Roman, Punic, phase too as the discussion of the finds below shows (*Cat. 44-46, fig. 29, cf. fig. 28*). The GPR survey has revealed evidence of a large rectangular structure at the western end of the field, probably related to the villa.³⁶ Future excavation will have to show whether we are dealing with a Roman/Late Antique or an earlier Phoenician/Punic structure. On the site, just below a large carob tree, a vat cut into a large limestone block was found and documented (fig. 15). It is probably one of the stone troughs reported early last century and it belongs to a type well known from other Roman villa sites in Malta, including the San Pawl Milqi establishment located about a kilometre away on the other, eastern, side of the Gebel Ghawżara slope (fig. 5).³⁷

In 2003, archaeologist Timothy Gambin, found the base of a late 5th- or 4th-century BCE Punic painted amphora (*Cat. 39, fig. 27*) while prospecting the area and surveying the olive grove as part of his doctoral studies. Having remained unpublished, it was decided to have it included in the survey finds, also because its precise find spot could be established by Gambin as tract B16. That tract yielded more material of Phoenician/Punic date (see *Cat. 40-41, fig. 27*).

A related location, corresponding to tracts B83 and B99, was also subjected to a GPR survey. It confirmed that the large rectangular cistern, rock-cut and lined with waterproof mortar, still visible at the surface, extended below the field. The survey also revealed a series of linear anomalies, some of which meet at right angles, which may correspond to a system of channels related to water management or, as appears more likely, limestone quarrying. Pottery counts, on the contrary, were rather low and would otherwise not be indicative of the presence of a site.

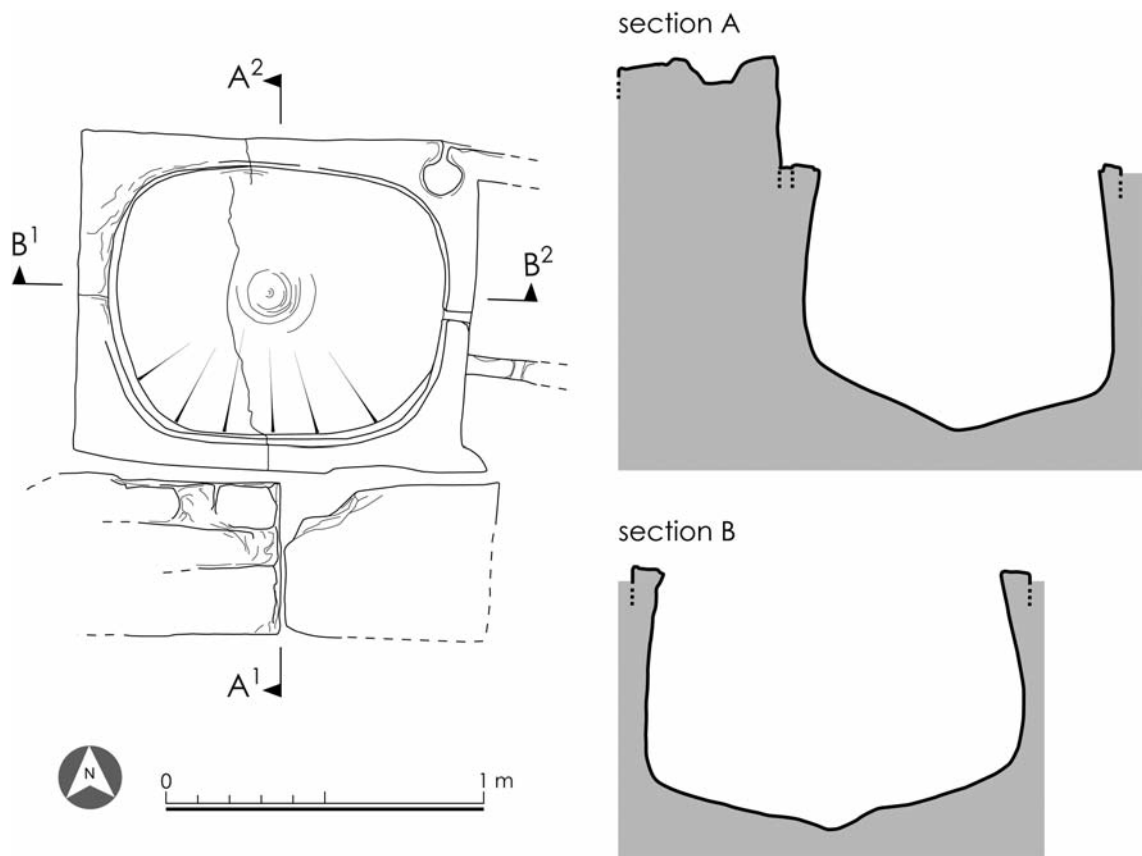

Fig. 15. Limestone vat, probably of Roman date, located in tract B21 – MSP2008/1/B21/F1 (drawing: Malta Survey Project, by RZ, digitised by MA).

A last tract belonging to this larger site or archaeological complex corresponds to a large but rather narrow field (tract B55; *fig. 5*). During the 2009 campaign, the pottery collected by field-walkers the previous year was studied by one of the pottery specialists (*WvdP*). He noticed that the finds were much more typical of a site, in view of the large amount of pottery sherds and building debris (fragments of tiles, brick, cistern lining, and fragments of plaster render), than for the regular background scatter of pottery often associated with past manuring activities.³⁸ The ashlar blocks observed at the base of the rubble retaining wall of the same field on its southern side, which had clear traces of mortar, also suggested that buried remains exist here. Moreover, interviews with tenant farmers suggest that this was in fact the field visited by Coleiro and Bonanno in the early 1970s. The site was therefore chosen for block survey and more than 1,200 artefacts were collected, with pottery dating to the Phoenician/Punic, Roman, Late Antique and Medieval

periods. The GPR survey carried out on this field produced spectacular readings at different depths: a large rectangular building to the east of the field, probably of Late Roman date, a building with two apses in the centre, either ecclesiastical of Medieval date or Roman or Late Antique of a secular nature (possibly a bath), as well as a cluster of buildings and structures towards the west where some Phoenician/Punic pottery was clustered (see also below, *fig. 17*).

The tracts mentioned above are relatively close to each other and are considered as forming part of one extended rural installation. Besides, two more rural sites have been identified in the 2008-2009 seasons. The first consists of a large concentration of building material and pottery fragments of Phoenician/Punic, Roman and Medieval date in tract A122, just off the main road to Bidnija (*fig. 5*) Unfortunately a GPR survey in this field did not yield any architectural remains in the subsoil. The extent of the sherd concentration, covering also adjacent fields, seems to exclude the

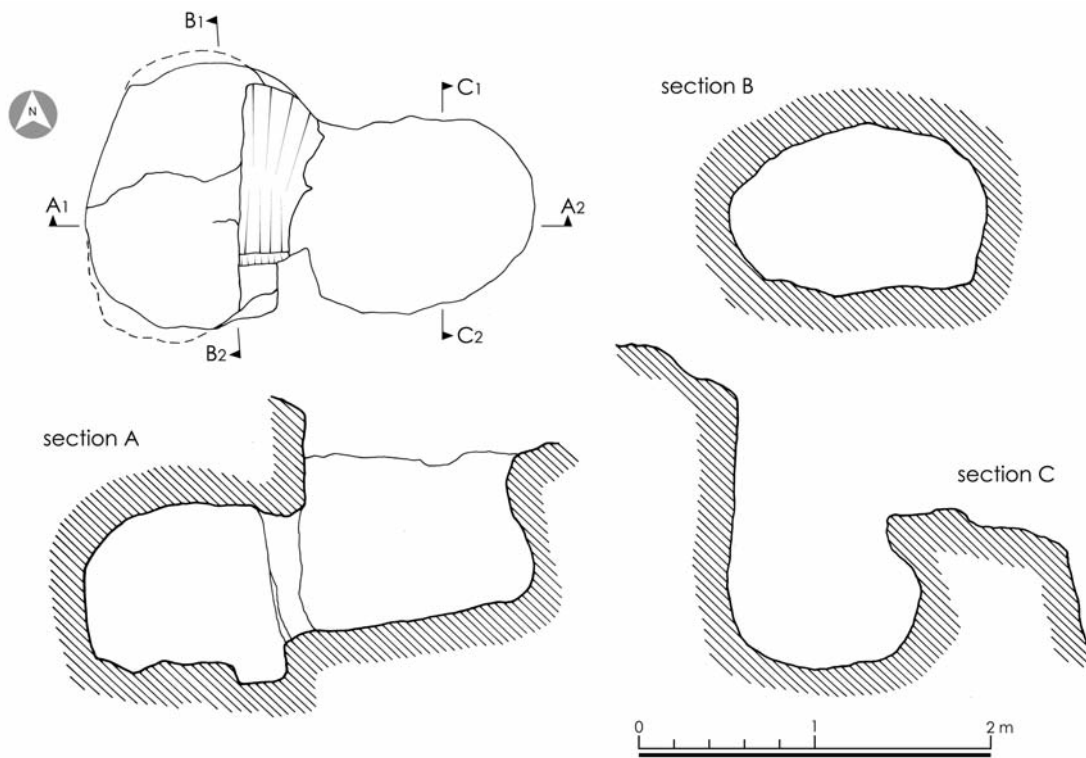

Fig. 16. Rock-cut tomb of Phoenician/Punic period on garigue area in tract B69, above tract B55, dated to the 6th or 5th century BCE – MSP2008/1/B69/F1 (drawing: MSP, by MA and NCV, digitised by MA).

possibility that we are dealing with a localised secondary dump of habitation material brought in from elsewhere. It is more likely that the concentration of pottery is related to an ancient unlocated rural establishment further up the hill, where an 18th-century CE farmstead (Tal-Għażzi) was built near a spring of water reached by a rock-cut gallery.³⁹ Behind the farmstead, in an area of garigue, a rock-cut rectangular feature has been recorded. It is very likely that this is the shaft of a Punic or Roman shaft-and-chamber tomb.

The third and last site encountered during the survey campaigns is the well-known rural villa site of San Pawl Milqi, explored by an Italian Archaeological Mission to Malta in the 1960s.⁴⁰ The villa falls just outside the survey transect but the adjacent fields within the survey transect yielded high concentrations of finds, mainly of Punic and (Late) Roman date (e.g. in tract C181; *Cat.* 9; *fig.* 20, see also *figs* 5, 9). Most of these tracts, however, have not yet received full and detailed study of the finds, so that any further comments - by necessity in relation with the published results of the Italian excavations of the site - will be left for the future.

In all, the MSP has yielded three rural sites, where we have clear evidence for human occupation in the Phoenician/Punic and Roman periods. The position of these rural sites in the landscape is also marked by the presence of no less than four rock-cut tombs, lying in three clusters. It is remarkable that one of these tombs has - up till now - no relation to a recognised site lying nearby. Three of the tombs are rectangular in shape, and may well be of Late Punic or Roman date, but one is of an earlier type. The rock-cut shaft is rounded and gives entrance to an equally rounded burial chamber. This feature is rather typical of rock-cut tombs of the Punic period, perhaps even as early as the 6th or 5th century BCE (*fig.* 16).⁴¹ This particular tomb, lying close to the escarpment, is situated just above tract B55 of the Ġebel Għawżara site just described. To our knowledge, the four tombs have not been previously recorded, although they all seem to have been emptied in the past. An isolated find from higher up the plateau may well have originated in such 'excavation' or grave-robbing activities: this is a fragment of a Punic lamp of Deneauve's type VII or VIII, dated to the 4th or 3rd century BCE (*Cat.* 60, *fig.*



Fig. 17. Horizontal Ground Penetrating Radar (GPR) slice from tract B55 at an estimated depth of 0.80-0.85 m, projected onto an orthophotograph of the area. On the GPR slice, white areas represent strong reflections indicating the presence of buried structures; in the dark areas, radar waves were not reflected or the reflection was weak (Image: MSP, prepared by LV).

33). Also the San Pawl Milqi villa has given excavated evidence of graves pertaining to the Punic period: a rock-cut rectangular chamber tomb T5 was found empty, but containing a fill with material of the 3rd to 2nd century BCE.⁴² It was situated at the north-western perimeter of the villa site and may well have belonged to the preceding Punic occupation of the site. The same site has also yielded a Punic funerary stele with inscription showing a standard funerary formula: 'Banay [or Ba'alay] son of Himilk son of (...)'.⁴³ The stele was found in secondary position, re-used in the foundations of the 17th-century CE church dedicated to St Paul, built over the remains of the villa. Although theoretically it could have been brought in from elsewhere in the area, it is more likely that it stemmed from the villa site itself; given the amount of available building material on the spot, there would

hardly have been any need to bring in more from farther afield.

The fact that the three sites recognised in the survey have given ample and concentrated evidence of architectural remains as floor and roof tiles, flooring, cisterns, etc. (see fig. 11) as well as evidence of graves, is highly suggestive of habitation sites that were permanently inhabited. All these sites lie at very short distances from each other along the escarpments of the garigue plateaux; the intermediate distances were ca 1 km and 700 m respectively. The finds of olive oil processing equipment on two of these sites (Gebel Ghawżara (fig. 15) and San Pawl Milqi) means that we are dealing with agricultural establishments that at least from the Roman period on centred on the (surplus) production of olive oil.⁴⁴

RFD, NCV, NC, AB, AP

As an integral part of the survey strategy it has been foreseen that those tracts where large concentrations of finds suggested the existence of ancient sites, would be investigated with a ground-penetrating radar (GPR). This was essentially done to confirm whether the high concentration of pottery sherds and other artefacts collected from the surface relate to buried structural remains. In so doing, the possibility that the artefact concentration could be the result of secondary soil dumping, often done to improve field depth and soil quality, was considered and eliminated. Moreover, the GPR can produce a good image of any buried remains, particularly structural features, even in Maltese soils as trials carried out between 26 and 30 April 2008 had shown.⁴⁵ Three areas or 'sites', one located along the southern escarpment of the Ġebel Ġhawżara plateau (B55) and two below it (B16 and B21), to the east of the present-day village of Bidnija, were chosen for block and GPR survey; all three produced very promising results and ceramic evidence dating also to the Phoenician/Punic period (see above).

By way of example, the results of the GPR survey on tract B55 are discussed. A Sensors & Software pulseEKKO PRO GPR was used with an antenna of centre frequency 500 MHz. Transects with a separation of 0.25 m were walked in zigzag mode (i.e. the first transect in ENE direction, the second one in WSW direction etc.). Along each transect, measurements were taken every 5 cm by means of an odometer wheel. Transects were materialized by guide ropes, within a grid laid out with a total station. This resulted in a set of vertical sections. These raw data were processed in Matlab. Processing included band-pass filtering (removing very low and high frequencies), amplifying the waves reflected by deeper structures (which are weaker as they have been travelling longer through the soil), removing linear noise caused by the instrument, and migration (a reconstruction of the true geometry of the buried structures by removing diffraction hyperbolae). Finally, the vertical sections were converted to horizontal slices with a thickness of 5 cm. Fig. 17, a horizontal slice at an estimated depth of 0.80-0.85 m, shows several structures probably belonging to a Roman or Late Antique villa and its possible predecessor of the Punic period. One of the rooms has two apses and might be interpreted as baths. The easternmost, long rectangular structure may perhaps be compared with a similar structure found on the San

Pawl Milqi villa site (see below). The remains show slightly different orientations, following the slope.

LV

SELECTED FINDS OF ALL PERIODS⁴⁶

Of the 29,309 finds that have been entered in the database, ca 300 have been studied in a more detailed manner, recorded with profile drawings, photographs and detailed fabric descriptions by several specialists (*BB, RFD, MA, NC*) with a view to final publication; 129 of these have been included in the reference collection. The guiding principle has been the study of all material from sites recognised during the survey. Apart from this context- or site-based study, a selection of diagnostic finds from 'off-site' areas in the survey transect has been studied by individual specialists (*BB, NC, CV, JW*).

As an impression for the range and scope of the finds encountered during the MSP, and in view of the fact that hitherto so little finds have been published from rural Malta (except of course from the San Pawl Milqi excavations), a small diachronic selection is presented and discussed here.

Prehistoric Periods

Cat. 1: MSP2008/1/B155/P2/4, 1 proximal flake, debitage (*fig. 18*).

Flint: very dark gray (2.5 YR N3/), light gray (5 YR 7/1) at and near flaked parts. L 2.6, W 1.9, mid Th 1.1, max. Th 1.2. Complex striking platform.

This un-datable lithic was originally deemed as worked. However, on close inspection, one should leave open the possibility that the micro-detachments evidenced on the margins of this lithic are in fact a by-product of plough soil damage. As such, *Cat. 1* is illustrative of the many 'lithic' fragments found in the survey that are definitely not to be considered as artefacts.

Cat. 2: MSP2008/1/B136/P7/1, 1 exhausted core (*fig. 18*). Flint: pinkish gray (7.5 YR 6/2) to white (10 YR 8/1), with some white and brown streaks. L 4.5, W 2.5, mid Th 2.0, max. Th 2.2. Simple striking platform.

This lithic, seemingly of Neolithic date, is made from a fine imported flint. Probably hailing from the Monti Iblei flint outcrops, this exhausted core fragment is typical of Maltese lithic technology. In particular, Maltese Neolithic cores seem to originate from pebble-sized nodules that are often knapped until the edges become too steep and therefore limiting any further knapping. In this lithic's case, since the material in question is imported and therefore valued, the lithic was rejuvenated repeatedly and abraded to provide new possibilities for flake detachment.

Cat. 3: MSP2008/1/F112/P10/1, 1 bimarginal tool, blade (*fig. 18*).

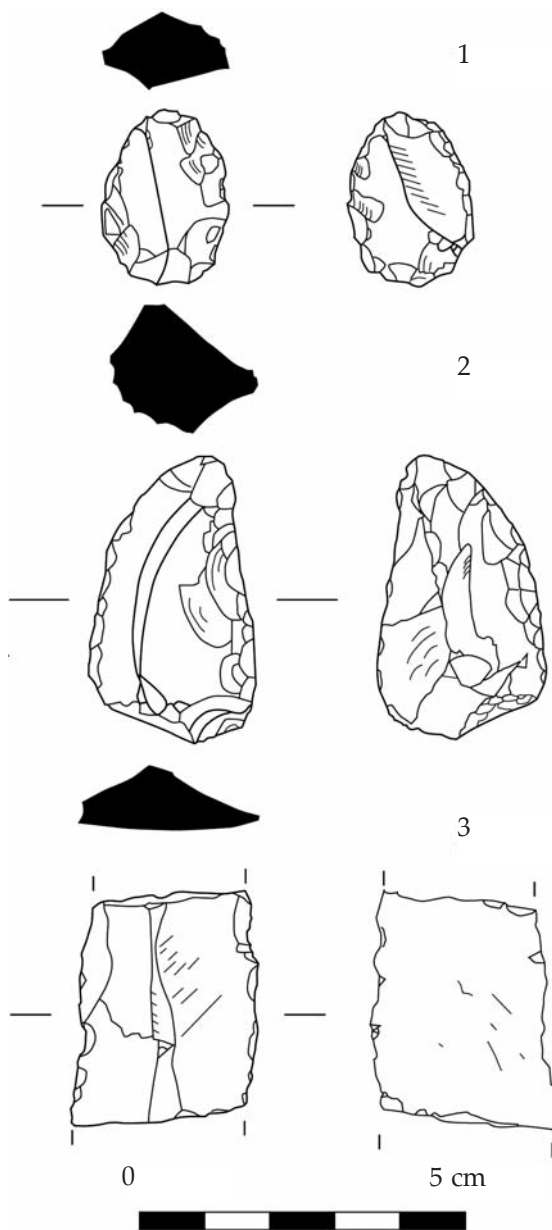

Fig. 18. Selected lithic objects of the Prehistoric period, Cat. 1-3 (drawing: MSP, by MA, digitised by Joris Angenon).

Flint: light gray (10 YR 7/2). PL 2.4, W 1.6, mid Th 0.8, max. Th 0.9.

This lithic fragment is a type of broken unretouched blade found across other Neolithic Maltese sites including Ta' Hagraat.⁴⁷ Currently at 2.4 cm in length, this unretouched blade can be approximated as originally standing at 3.5-4.0 cm. It is also worth noting that this lithic has no proximal or distal end due to use and was probably hand-held. As in other Maltese sites, blades

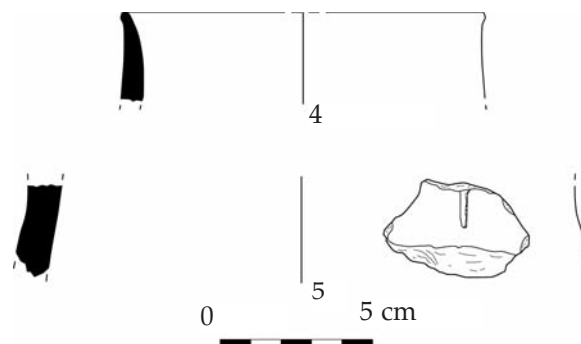

Fig. 19. Selected pottery of the Prehistoric period, Cat. 4 (carinated) bowl of the Tarxien phase; Cat. 5 open vessel in Borġ in-Nadur Ware (drawings: MSP, by RFD, digitised by Joris Angenon).

manufactured from imported stone tend to lack intentional edge retouching. This appears to reflect a preference for imported flints that can be knapped at thinner thicknesses, leading to sharper blade edges that require no further retouching. Furthermore, the lack of intentional retouching also suggest that the lithic was used longitudinally as a cutting and not a serrating implement on soft to medium materials.

Cat. 4: MSP2008/1/B64/W1/1, 1 rim fragment of a (carinated) bowl (fig. 19).

Medium fired, rather thin-walled, fine grayish brown clay (2.5 Y 5/2) tempered with few dark grey particles (0.2-0.3mm) and few white (lime?) particles (0.2mm), gray (5 YR 7/6) on surfaces; lime encrustations all over. Diam. Rim 12, PH 3.0.

The fragment clearly belongs to a grey ware vessel of the Temple period, dating to the Tarxien phase (c. 3000-2500 BCE). The shape probably belongs to the classic carinated offering bowl form classified by Evans as his shape 41/42.⁴⁸ This type of bowl is frequent in most temple sites and funerary hypogea in Malta and Gozo.⁴⁹

Cat. 5: MSP2008/1/D79/P2/1, 1 fragment of large open vessel (fig. 19).

Medium fired, coarse handmade, reddish brown clay (5 YR 4/3) with angular and sub-rounded stone particles (2mm), pink (7.5 YR 7/4) on exterior, burnished, dark gray (5 YR 4/1) on interior, burnished. Vertical scratch before firing. PH 3; max. Diam. 18.

The fragment belongs to the handmade pottery repertoire also known as Borġ in-Nadur Ware, which is dated to the Maltese Middle and Late Bronze Age (ca 1450-850 BCE) and would come close to Tanasi's fabric 5 (Coarse Ware, which has a roughly polished surface);⁵⁰ it is difficult, however, to make out the original shape.

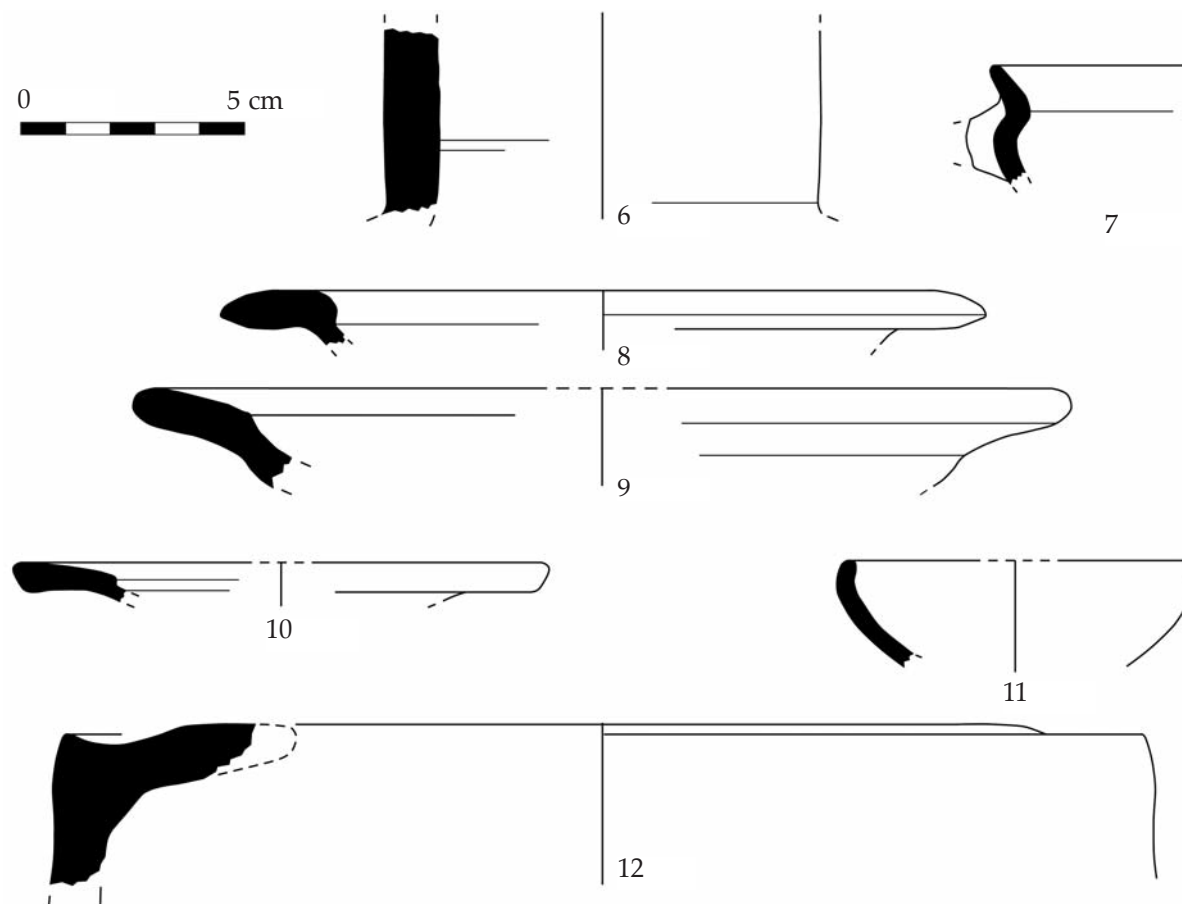

Fig. 20. Selected pottery of the Phoenician/Punic period, Cat. 6 Corinthian A transport amphora; Cat. 7 local skyphos/kylix; Cat. 8-10 local plates; Cat. 11 local bowl; Cat. 12 Carthaginian transport amphora (drawings: MSP, by RFD, digitised by Joris Angenon).

Phoenician/Punic Period

Cat. 6: MSP2008/1/A112/P3/2, 1 neck fragment of Corinthian A transport amphora (fig. 20).

Hard fired light brown (7.5 YR 6/4) clay with light yellowish brown core (10 YR 6/4) containing some dark brown to reddish brown angular mudstone (0.2-3.0 mm), pink (7.5 YR 7/4) surface. PH 4.1; Diam. neck 10. The clay of this fragment is very characteristic of Corinthian A type transport amphorae as defined by C.G. Koehler.⁵¹ These handmade or rather hand-built olive oil containers knew a very wide distribution from the 8th to the 5th century BCE. The rather narrow neck of the present piece is more characteristic of versions of the (last quarter of the) 6th and first quarter of the 5th century BCE, a period in which these vessels were still widely distributed in the Mediterranean and the Black Sea.⁵² Especially Gela and Camerina in southern Sicily seem to have been well served, which is of some interest given their relative closeness to Malta.⁵³ Carthage, on the contrary, has yielded relatively few of such vessels (8 from the settlement and none from the necropoleis).⁵⁴

Thereafter, during most of the 5th and the 4th centuries BCE, Corinthian A type amphorae seem to be confined primarily to Corinth itself.

Cat. 7: MSP2008/1/D2/P2/2, 1 rim fragment with handle root of a local skyphos or kylix (fig. 20).

Medium fired, soft reddish yellow (5 YR 6/8) clay with few small white (lime) and red inclusions, surface very eroded (no trace of slip or other decoration). PH 2.5; Diam. rim ?

The sanctuary site of Tas-Silġ in south-east Malta has provided evidence of several local skyphoi of this type, very comparable to Cat. 7.⁵⁵ For Malta, the shape has been discussed by A. Ciasca,⁵⁶ and Sagona.⁵⁷ These drinking vessels occur also without handles in the Maltese repertoire. Sagona dates the shape to her Late Phase I and Phase II, i.e. to between 620 and 500 BCE. In comparative perspective this is to be considered as a fairly late date for the adaptation of this particular Greek form. Indeed, also from a morphological point of view, the Maltese versions seem to adapt more closely the late 7th- and 6th-century BCE East-Greek kylikes

than the general (Sub-)Geometric skyphoi of the 8th and 7th centuries BCE, whatever this may imply.⁵⁸ The survey has yielded several fragments of such cups.

Cat. 8: MSP2008/1/D70/P6/1, 1 rim fragment of a local plate (*fig. 20*).

Hard fired red (2.5 YR 5/6) clay with grey core, containing some voids (0.1-0.4 mm), some very fine quartz 0.1 mm, isolated foraminifera, surface weak red (2.5 YR 5/4). PH 1.2, Diam. rim 17.

The re-study of older finds from excavations of the Italian archaeological mission in Tas-Silġ ('area nord') by A. Quercia has provided us with the best typological study of the most common pottery types occurring in the sanctuary. Plates figure prominently amongst these finds.⁵⁹ The particular rim shape of *Cat. 8*, however, finds no parallel within the plate typology established by Quercia and it may be suspected that in this case we are dealing with an older type of the 8th, 7th or 6th century BCE. It might have belonged to a plate of A. Peserico's type P1.I, which finds its main distribution in Carthaginian contexts of the second half of the 8th and the first half of the 7th centuries BCE.⁶⁰ Although it can still be found in contexts of the following hundred years, Peserico pleads for a production till the middle of the 7th century BCE. However, the fact that the present fragment is of local Maltese production and, hence, may have been subject to a different morphological development than the Carthaginian plates, should warn for placing too high dates to the fragment.

Cat. 9: MSP2008/1/C181/W101/1, 1 rim fragment of local plate (*fig. 20*).

Hard fired light red (2.5 YR 6/8) clay with many small white and yellowish particles, probably foraminifera (0.2-0.3 mm), and some red particles (1-2 mm) [sample no 59], surface covered with secondary white calcareous deposit (2.5 Y 8/2). PH 2.3, Diam. rim 21.

The rim may be compared to several complete profiles excavated in the sanctuary of Tas-Silġ: two from the 'area sud', with suggested dates of the 5th and 5th/4th centuries BCE, respectively.⁶¹ The first one shows a lesser inclination, though. Also two plates from 'Fossa II' in the 'area nord' are very comparable.⁶² The finds in the context are dated to the last quarter of the 4th century BCE. The recent typology of plates by Quercia, would range this particular rim shape within his type 5, which on the basis of a sound seriation is dated to the 5th but more frequently to the 4th and 3rd centuries BCE.⁶³

Cat. 10: MSP2008/1/D23/P3/1, 1 rim fragment of local plate (*fig. 20*).

Hard fired light red (2.5 YR 6/8) clay with fine foraminifera and lime inclusions, surface fired grey. PH 0.9, Diam. rim 12.

The squarish rim end of *Cat. 10* may be compared to a plate with painted lines excavated in the 'area sud' of the sanctuary of Tas-Silġ, which is tentatively dated to the 5th century BCE.⁶⁴ Another plate with comparable morphology from Tas-Silġ has been published from 'Fossa II', dated to the last quarter of the 4th century BCE.⁶⁵ The rim shape does not find an exact parallel in the plate typology of Quercia, but given the comparatively small rim diameter it may rather have belonged to his class of 'piattelli' or small plates.⁶⁶

Cat. 11: MSP2008/1/A42/P2/1, 1 rim fragment of local bowl (*fig. 20*).

Hard fired light red (2.5 YR 6/8) clay with some limestone inclusions (0.1-0.2 mm and few 0.5-1.0 mm), surface reddish yellow (5 YR 7/8). PH 2.3, Diam. rim 8. The small bowl is a Maltese version of the Attic saltcellar 'later and light', the originals of which occur not earlier than the late 5th and 4th centuries BCE.⁶⁷ These local versions of these Attic bowls with incurved rim (both small and large ones) are fairly common in the ceramic repertoire of Punic Malta, as M.P. Rossignani already observed in 1973. She dates the examples in the sanctuary of Tas-Silġ to the 5th century BCE, those with slip and lighter and more levigated clay to the first half of the 4th century BCE; dates that probably should be corrected for the smaller versions as *Cat. 11*.⁶⁸ Original Greek Black Glaze versions of such bowls have been found in Tas-Silġ too.⁶⁹ The recent typology of Maltese pottery of the Phoenician/Punic period of Quercia also discusses these bowls, with generally lower dates, though.⁷⁰

Cat. 12: MSP2008/1/B99/P3/1, 1 rim fragment of Carthaginian transport amphora (*fig. 20*).

Hard fired red (2.5 YR 5/6) clay with many well-sorted rounded quartz (0.2-0.3 mm), 'KTS', surface reddish yellow 5 YR 6/6). PH 3.7, Diam. rim 24.

The amphora may be attributed to J. Ramón's type T-5.2.3.1, of Carthaginian production.⁷¹ This type of amphora is dated to the last quarter of the 3rd and the first quarter of the 2nd centuries BCE, although the present fragment may still be assigned a date in the 3rd century BCE. A comparable amphora stored at the National Museum of Archaeology in Valletta has been published.⁷² The fabric description ('pinkish-brown fabric') is vague enough to include a Carthaginian production for this amphora too.

Hellenistic Period

Cat. 13: MSP2008/1/A61/P5/1, 1 rim fragment of Carthaginian transport amphora (*fig. 21*).

Hard fired light red (2.5 YR 6/6) clay with many well-rounded quartz (0.2-0.3 mm), 'KTS', surface reddish yellow (5 YR 6/6) and few traces of a yellowish scum. PH 4.8, Diam. rim 20.

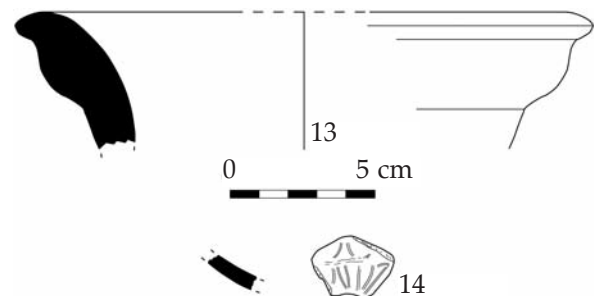

Fig. 21. Selected pottery of the Hellenistic period, Cat. 13 Carthaginian transport amphora; Cat. 14 imported mould-made relief bowl (drawings: MSP, by RFD, digitised by Joris Angenon).

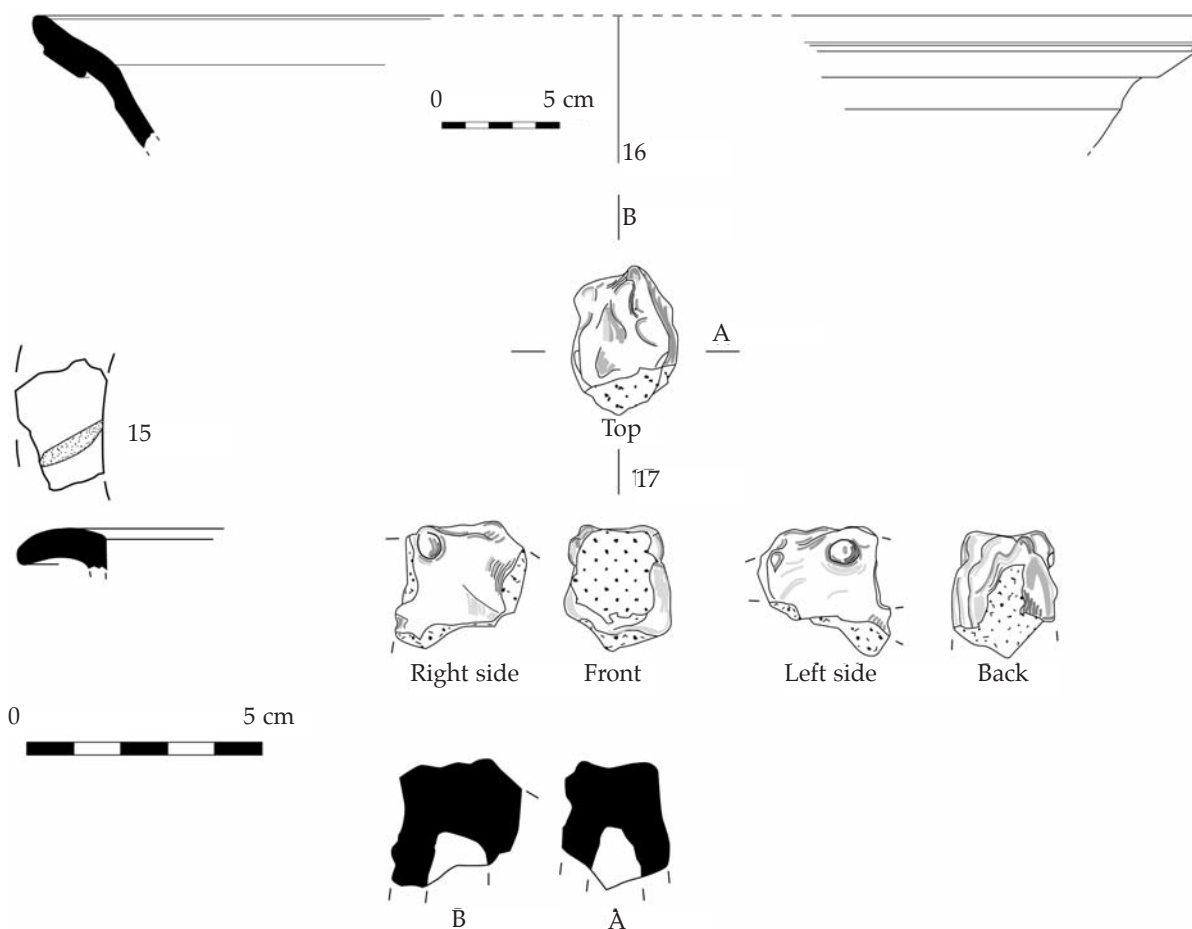

Fig. 22. Selected pottery of the Roman period, Cat. 15 North African dish; Cat. 16 local large platter or dish; Cat. 17 terracotta zoomorphic figurine (drawings: MSP, by RFD and MA, digitised by Joris Angenon).

On the basis of the rather steep inclination of the rim, the amphora fragment may perhaps be attributed to Ramón's type T-7.2.1.1, generally produced in the Tunisian Sahel, and apparently also in the western Tripolitania and western Sicily (Carthage is not mentioned among the possible production places).⁷³ The dating suggested by Ramón sets the type in the last third of the 3rd and the first decades of the 2nd centuries BCE. A more likely candidate, however, will be the first half of the 2nd century BCE amphorae of Ramón's type T-7.4.1.1, produced in the area of Tunisia, or possibly the Sahel and Tripolitania.⁷⁴ The clay of this type is attributed to Ramón's group 'Cartago-Túnez'. The sanctuary of Tas-Silg has yielded another rim fragment of this type of amphora.⁷⁵

Cat. 14: MSP2008/1/E80/P1/1, 1 wall fragment of Attic (?) mould-made relief bowl (fig. 21).

Medium fired gray (10 YR 5/1) clay with isolated grey rounded particle, dark brown subangular particle and void (0.3 mm), traces of Black Glaze on both sides. Surface feels powderish, soft; probably secondarily burnt. The small fragment may belong to an Attic relief bowl,

but the burnt state prohibits the recognition of the typical Attic fabric.⁷⁶ Attic mould-made relief bowls were produced between ca 240 and 80 BCE, perhaps even till the late 1st century BCE. In any case, an attribution to one of the later Italian or Sicilian relief bowl production centres, active between ca 180 and 75 BCE, may be excluded on the basis of the presence of a true Black Glaze. It is difficult to establish the inclination of the present fragment; in fact, the decoration consisting of an egg-and-dart/ovolo above a double horizontal line and floral (?) viz. petal (?) decoration below would suggest a steeper inclination and a portion of the upper wall.⁷⁷ The excavations by Zammit at the Roman Domus of Rabat/Mdina in 1922 yielded fragments of no less than 20 relief bowls.⁷⁸

Roman Period

Cat. 15: MSP2008/1/B156/P2/4, 1 rim fragment of a North African dish ARS 3B (fig. 22).

Hard fired light red (2.5 YR 6/6-8) clay with some small quartz and few blackish inclusions, traces of Red

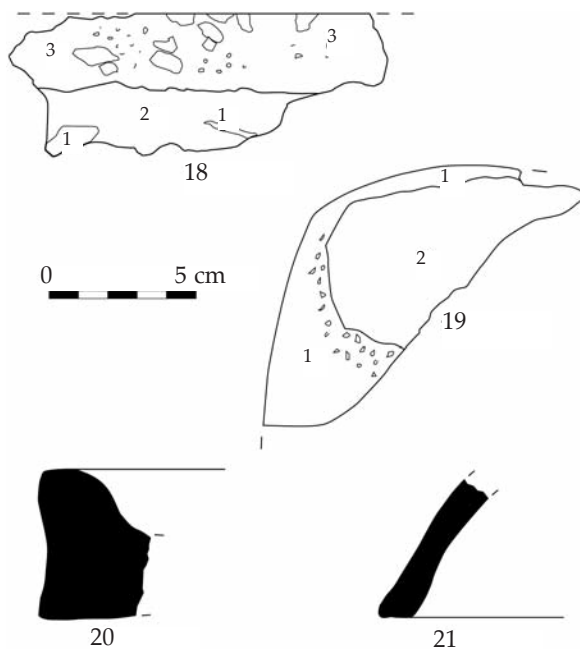

Fig. 23. Selected building material of the Hellenistic/Roman period, Cat. 18 section of terrazzo flooring; Cat. 19 section of terrazzo moulding of a bench (?); Cat. 20 local tegula; Cat. 21 local imbrex (drawings: MSP, by RFD, digitised by Joris Angenon).

Slip on surface. PH 0.8, Diam. rim ?

The rim shows a decoration in the barbotine technique. It belongs to a dish of J. Hayes' form ARS 3B, dated to ca 75-150 CE.⁷⁹ More recently, J. Lund, established a precision of the chronology of the form on the basis of coin-dated contexts in the Mediterranean: 60/80 to 160/180 CE.⁸⁰

Hellenistic/Roman Period

Cat. 16: MSP2008/1/A57/P4/1, 1 rim fragment of a large platter or dish (fig. 22).

Hard fired light yellowish brown (2.5 Y 6/4) clay with many angular black particles (0.2-0.3 mm) and some quartz (0.3-0.4 mm), surface pale yellow (2.5 Y 7/4). The piece is covered with calcareous encrustations, mainly on the interior. PH 5.7, Diam. rim 51.5.

The date of these large platters or dishes remains to be ascertained, although a general date in the Hellenistic or Roman period, viz. the last two centuries BCE and the first three centuries of the CE, seems very well possible. In fact, in the discussion of the finds of Tract MSP08/B21 B. Bechtold tentatively attributes the rim of a similar vessel ('basin') to the Hellenistic period (Cat. 53, fig. 31). Similar rims seem to occur in archaeological contexts of the San Pawl Milqi site, dating to the 1st century BCE to the first half of the 2nd century CE.⁸¹ A comparable rim in the category of 'cream-coated coarsewares' with a diameter of 38 cm has been published from the Hal Millieri site in south-eastern

Malta.⁸² In view of the morphological similarity with ARS 99 bowl rims, it has been tentatively dated to the 6th century CE. These bowls generally are (much) smaller, though. 'Cream-coated coarsewares', most likely covered with scum or 'salt-slip', occur from the Phoenician/Punic period to Late Antiquity.

Cat. 17: MSP2008/1/A122/BS4/7, 1 head fragment of a terracotta zoomorphic figurine (fig. 22).

Hard fired yellowish red (5 YR 5/8) clay with lime, shell, quartz (?) and fine red inclusions, surface covered by pale yellow (2.5 Y 8/3) scum, but mostly worn. PH 2.7, W 2.3, PL 2.8.

The heavily damaged fragment of a mould-made terracotta seems to represent the head of a cow or a horse. The state of preservation prohibits any firm suggestions as to dating, although both the Phoenician/Punic and the Roman period have yielded examples of zoomorphic figurines on Malta.

Phoenician/Punic graves have yielded some examples of terracotta figurines.⁸³ To these, one may add a terracotta of a petaike, presumably found on Malta and now in the Allard Pierson Museum, Amsterdam, that in view of its state of preservation may have been found in a tomb as well.⁸⁴ The occurrence of terracotta figurines in sanctuary contexts is another, well-attested possibility. By way of example for the large and important sanctuary site of Tas-Silġ one may quote Rossignani on the 1970 finds: 'molti frammenti di ex-voto fitili, dall'età arcaica a quella ellenistica, di produzione siciliota e magno-greca'.⁸⁵ As a functionally better comparison for the present find in tract A122, one should mention the figurine fragment and the human protomes found in a votive deposit in the rural villa of San Pawl Milqi, with material dated to the end of the 4th century BCE till the 1st century CE.⁸⁶

Cat. 18: MSP2008/1/B99/P4/1, 1 fragment of terrazzo flooring with regularly spaced, inset white marble tessellae (fig. 23).

The flooring fragment consists of two layers: a 2.5 cm thick white to grey mortar layer (fig. 23, 18, no 2) with fragments of white limestone (fig. 23, 18, no 1), above which an equally thick top layer of reddish yellow (5 YR 6/8) crushed pottery fragments in a white mortar bedding (fig. 23, 18, no 3). The white marble tessellae are 1.2 x 1.2 cm and 1.2 x 1.5 cm. The surface is smoothed. PH 5.0, PL 13.0.

In Carthage, this type of flooring would constitute a typical example of the Punic pavements, the *pavimenta punica*.⁸⁷ Also the North African Punic town of Kerkouane, destroyed in 255/254 BCE, has yielded several examples of this type of flooring.⁸⁸ In Malta, however, one would hesitate to confine the occurrence of these pavements to the Punic period, since they might have been produced well into the Roman period. The San Pawl Milqi villa has yielded some fragments of similar pavements, albeit with irregularly spaced white marble tessellae.⁸⁹

Cat. 19: MSP2008/1/B61/W1/2, 1 fragment of terrazzo moulding of a bench (?) (fig. 23).

The base material of the terrazzo moulding consists of fine (0.3-0.5 mm) crushed pottery fragments in a white to grey mortar bedding (fig. 23, 19, no 1). The pottery

fragments are larger towards the interior (3.0-4.0 mm), where also a large limestone of the bench (?) construction has been preserved (fig. 23, 19, no 2). The overall colour is pink (5 YR 7/3). The surface is smoothed; on the vertical part covered with a layer of white lime. PH 9.0, PW 10.8.

The well-preserved Punic site of Kerkouane has several examples of benches executed in rubble masonry and covered with *terrazzo*.⁹⁰ Alternatively, one should not exclude the possibility that the fragment belonged to the rim of a cistern or a basin.

Cat. 20: MSP2008/1/B21/BS7/28, 1 edge fragment of a *tegula* (fig. 23).

Hard fired light reddish brown (5 YR 6/4) clay with some angular dark grey stone particles (0.3-1.5 mm), few red particles (*chamotte*?; 0.2 mm) and isolated iron concretion-like inclusion (1.5 mm), surface very pale brown (10 YR 8/3) scum all over. PH 5.2, PW 3.9.

Cat. 21: MSP2008/1/B21/BS5/2, 1 rim fragment of an *imbrex* (fig. 23).

Hard fired red (2.5 YR 5/6) clay with some dark reddish particles (1.0-1.5 mm) and many very fine white foraminifera (less than 0.1 mm), surface pale yellow (2.5 Y 8/3) scum all over. Exterior surface smoothed, roughened on interior.

The *tegula* and *imbrex* fragments presented here belong to a fairly large group of tile fragments encountered in the survey. Some are clearly of local production, such as *Cat. 20-21*, but others seem to have been imported from different production places. They may well date to the Roman period, if not to the Late Antique period; an earlier date is probably to be excluded since roof tiles from the Phoenician/Punic period are extremely uncommon.⁹¹ Other tile fragments in the survey material have been attributed to the Medieval period (NC).

Cat. 22: MSP2008/1/B21/BS11/35, 1 edge fragment of a brick (fig. 24).

Hard fired red (2.5 YR 5/6) clay with wide grey core, containing many angular to sub-angular quartz and black particles (0.2-0.5 mm) and some limestone particles (0.2-0.5 mm), surface light gray (2.5 Y 7/2) scum all over. Surface partly covered with grey mortar. H 7.4, PW 7.5, PL 9.4.

The brick seems to be of local manufacture. The occurrence of black particles in some of the local clays of the Maltese islands can be explained by the occurrence of Glauconite in the so-called Greensand formations.⁹² Fragments of similar large bricks can be seen lying around in the San Pawl Milqi villa.⁹³ They seem to be of similar fabric.

Cat. 23: MSP2008/1/B21/BS11/37, 1 edge fragment of a terracotta doweled floor tile (fig. 24).

Hard fired reddish brown (5 YR 5/3) clay with some dark reddish brown particles (0.5-1.0 mm), some limestone particles (0.2-0.5 mm) and some sub-angular quartz (0.2-0.5 mm), surface light gray (2.5 Y 7/2) scum all over. Th 6.7, PL 8.2, PW 11.0.

The tile shows clear signs of a broken off dowel at the preserved side. This feature is encountered several times in the North African, Carthaginian Punic world in terracotta floors of the 3rd century BCE.⁹⁴ In these

cases the terracotta floor is mostly hexagonal and more-over of comparable thickness (5-8 cm).⁹⁵ It is exactly the larger dimensions that sets the Punic terracotta floor tiles apart from the Roman ones as A. Mezzolani already suggested for the lozenge-shaped ones (see below).⁹⁶

Cat. 24: MSP2008/1/A148/P10/19, 1 triangular terracotta floor tile (fig. 24).

Hard fired reddish yellow (5 YR 6/6) clay, probably with darker or grey core (as suggested by the chipped edge), containing some quartz and foraminifera (0.2-0.3 mm) and some limestone particles (0.3-0.5 mm), surface reddish yellow (5 YR 6/6). Th 1.5, W sides 5.

Cat. 25: MSP2008/1/B21/P6/10, 1 fragment of rectangular terracotta floor tile (fig. 24).

Hard fired light red (2.5 YR 6/6) clay with some quartz and limestone particles (0.1-0.2 mm), surface reddish yellow (5 YR 6/6). Mortar traces on one of the sides. Th 1.5, PW 3.3, PL 4.4.

Although the two tiles *Cat. 24-25* were found in different zones of the survey area, the remarkable fact that they share the same thickness may suggest that they were produced in the same period, if not in the same workshop.

Cat. 26: MSP2008/1/B35/P1/5, 1 fragment of lozenge-shaped terracotta floor tile (fig. 24).

Hard fired light red (2.5 YR 6/6) clay with wide grey core, containing many foraminifera (0.1-0.2 mm), some dark brown particles (0.2 mm), few white particles (0.2 mm) and some quartz (0.2-0.3 mm), surface light yellowish brown (2.5 Y 6/4). Over the centre runs a line in relief from the mould, in which the tile was formed. Th 2.2, PW 8.0, PL 7.3 (original dimensions of the piece: 2.2 x 15 x 8.5).

Cat. 27: MSP2008/1/B37/C1/1, 1 fragment of hexagonal terracotta floor tile (fig. 24).

Hard fired pale brown (10 YR 6/3) clay with many black particles (0.2-0.3 mm) and few translucent quartz (0.2-0.4 mm), surface light brownish gray (10 YR 6/2). Th 2.2, W 7.5, PL 6.3 (original dimensions of the piece: 2.2 x 7.5 x 9.0).

The fact that *Cat. 26-27* share the same thickness and were found in the same zone would suggest that they belonged to the same floor system. The same type of flooring, especially with the lozenge-shaped tiles, has been found elsewhere on Malta, in the San Pawl Milqi villa and in the Roman Domus at Rabat/Mdina.⁹⁷ In the latter case we are dealing with the central piece of Room B offering an 'illusionistic design consisting of a pattern of cascading cubes in perspective formed by lozenge-shaped tiles of three different colours (*opus scutulatum*). The series of floors and mosaics in the Domus are dated between the last quarter of the 2nd century till the middle of the 1st century BCE. The tile floor in the San Pawl Milqi villa is less intricate. The lozenge-shaped tiles form a sort of repetitive fishbone pattern in a small annex.⁹⁸

The Punic world has also given evidence of lozenge-shaped terracotta floor tiles, both in Carthage and in Kerkouane, although these seem to be of larger dimensions (e.g. 22/23 x 12 x 5 cm).⁹⁹

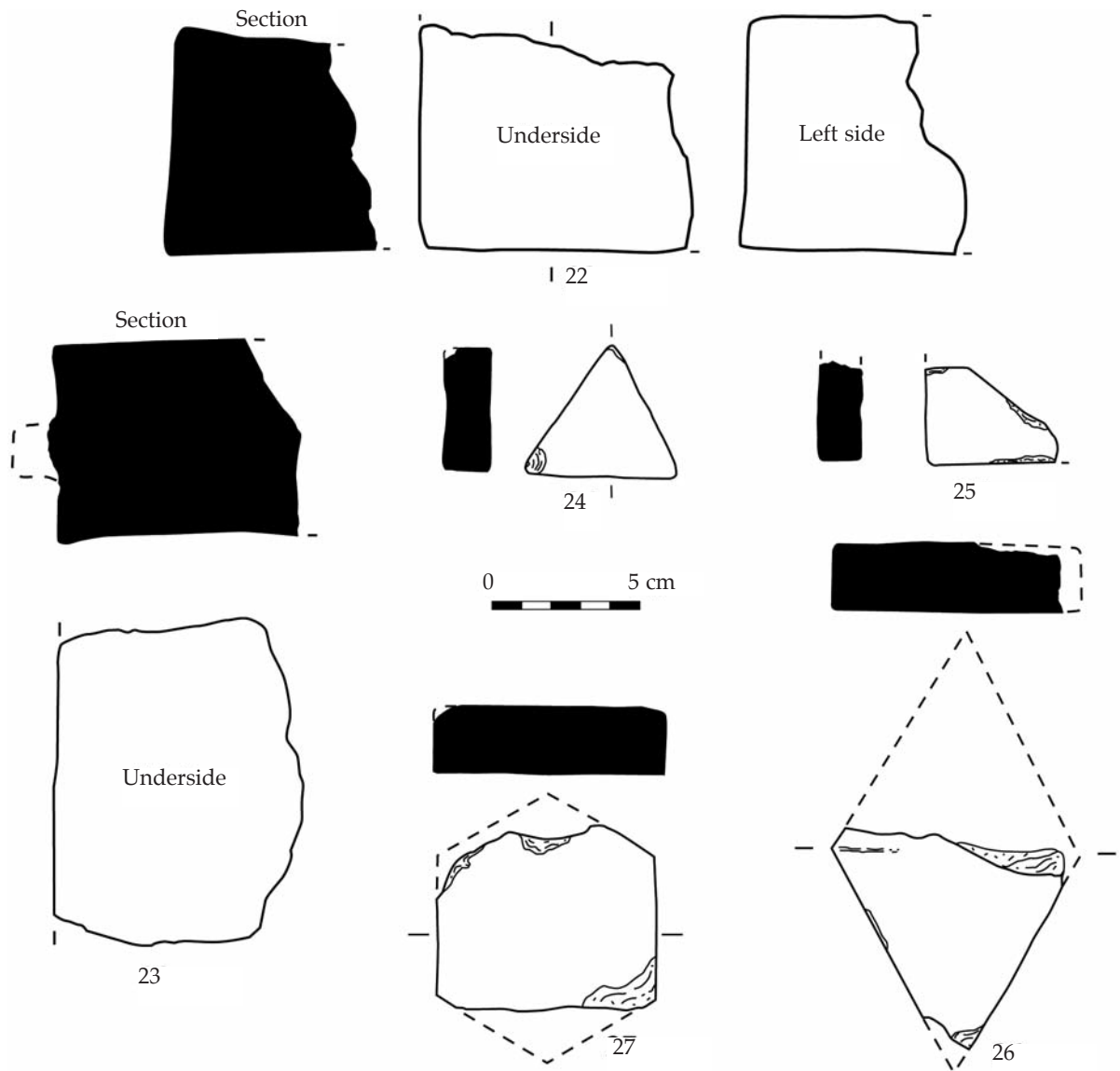

Fig. 24. Selected building material of the Hellenistic/Roman period, Cat. 22 local brick; Cat. 23 terracotta doweled floor tile; Cat. 24-27 local terracotta floor tiles (drawings: MSP, by RFD, digitised by Joris Angenon).

Late Antiquity

Cat. 28: MSP2008/1/B152/P7/1, 1 rim fragment of large North African dish/bowl or plate ARS 104 or 105 (fig. 25).

Hard fired red (2.5 YR 5/8) clay with many rounded quartz (0.1-0.2 mm) and few yellowish lime particles (0.3 mm), surface light red (2.5 YR 6/6). PH 1.9, Diam. rim 26. The rim belongs to either a dish/bowl of Hayes' form ARS 104, dated to ca 530-625+ CE or form ARS 105, dated to ca 580/600-660+ CE.¹⁰⁰ More recently, Lund established a precision of the chronology of the two forms and their several subtypes/variants on the basis of coin-dated contexts in the Mediterranean: 430/440

to 610/620 CE for ARS 104 and 520/540 to 660/680 CE for ARS 105.¹⁰¹ Especially a rim of ARS 105 (variant 4) found in the Segermes Valley Survey in northern Tunisia is close in shape.¹⁰² In their discussion of Byzantine Malta, B. Bruno and N. Cutajar consider the ARS 105 as a determining element of the '*facies ceramica di Malta bizantina*'.¹⁰³ It occurs in San Pawl Milqi ('*soprattutto H. 105*'), in the sondages of the Palazzo Xara in Mdina, on Gozo in Rabat/Victoria, and in the Tar-Raġhad tomb in Mġarr (Malta).¹⁰⁴ ARS 104 is attested in tombs discovered at Tal-Barrani (Żejtun) in 1993 and in the Tar-Raġhad tomb as well.¹⁰⁵ More or less comparable rims have been found in the earlier excavations at the sanctuary site of Tas-Silġ.¹⁰⁶

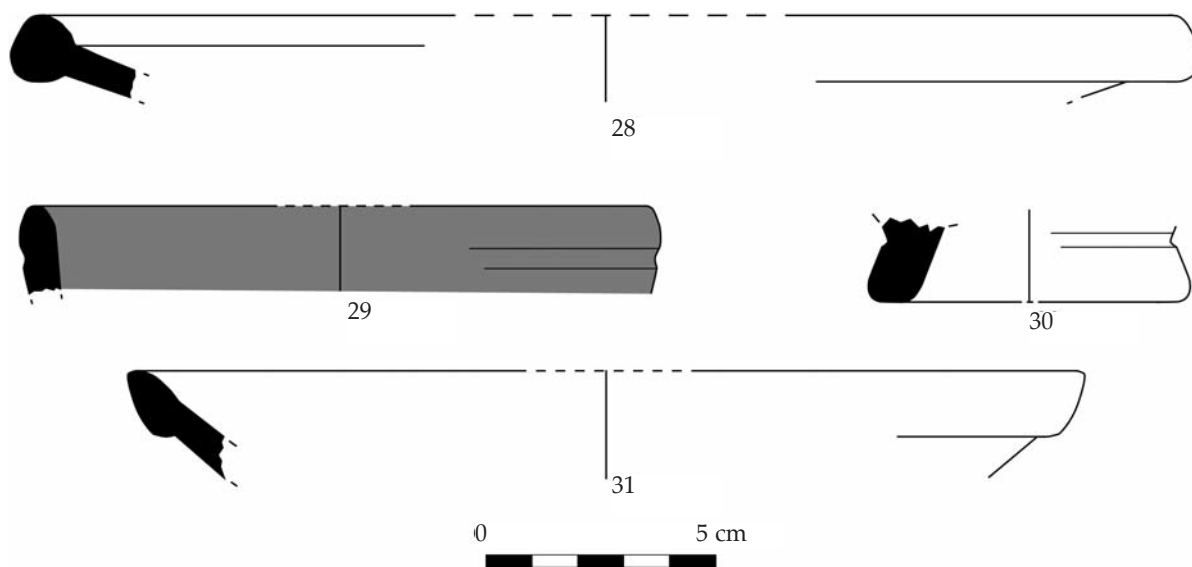

Fig. 25. Selected pottery of the Late Antique, Early Medieval and High Medieval periods, Cat. 28 North African dish/bowl or plate; Cat. 29 North African (?) cooking pot; Cat. 30 North African (?) bowl; Cat. 31 local (?) open vessel/dish (drawings: MSP, by RFD, digitised by Joris Angenon).

Early Medieval Period

Cat. 29: MSP2008/1/A13/P1/1, 1 rim fragment of North African (?) cooking pot (Fig. 25).

Medium fired red (10 R 5/6) clay with many rounded quartz (0.1-0.2 mm), surface weak red (10 R 4/3 – 5/3) matt glaze all over, slightly crackle. PH 1.9, Diam. rim 14 (?).

The rim may be dated to the 9th or 10th century CE on the basis of unpublished comparisons from excavations elsewhere on Malta.

High Medieval Period

Cat. 30: MSP2008/1/A1/P2/2, 1 base fragment of a North African (?) bowl (fig. 25).

Hard fired light red (2.5 YR 6/6) clay with some quartz, greyish particles and foraminifera (0.1 mm), surface covered with yellowish layer all over, green glaze preserved in ridge and on outside of ring base. PH 1.8, Diam. base 7.

It may be dated to the 11th-13th century CE on the basis of unpublished comparisons from excavations elsewhere on Malta.

Cat. 31: MSP2008/1/A8/P3/2, 1 rim fragment of an open vessel/dish (fig. 25).

Hard fired very pale brown (10 YR 8/4) clay with isolated manganese particle (0.2 mm) and some quartz (0.1-0.2 mm), surface covered with brownish yellow (10 YR 6/6) layer all over, green glaze preserved in ridges. PH 2.5, Diam. rim 20.

The clay properties would leave open the possibility of a North African production, but a local production seems not to be excluded either. It may be dated to the 11th-

13th century CE on the basis of unpublished comparisons from excavations elsewhere on Malta.

Early Modern Period

Cat. 32: MSP2008/1/A2/P3/1, 1 rim fragment of a local bowl (fig. 26).

Hard fired yellowish red (5 YR 5/6) clay with many greyish white limestone (?) particles, foraminifera and quartz (0.2-0.4 mm), as well as few manganese (?) particles (0.3 mm), surface pink (7.5 YR 7/4). PH 3.6, Diam. rim 22.

The clay characteristics have been termed 'white speckled' in the finds laboratory and seem to be fairly typical for local productions of the Early Modern period. The bowl may be dated to the 16th-17th century CE on the basis of unpublished comparisons from excavations elsewhere on Malta.

The following five tobacco pipe fragments (Cat. 33-37, fig. 26), are in the chibouk style, known in Maltese as *pipa tal-qasba* or reed pipe. The terminology follows that established by R. Robinson.¹⁰⁷ Tobacco pipes were introduced in the Mediterranean around 1600, developing over the next two centuries. Early pipes were fired grey and were superseded by browns and reds during the 18th century CE, increasing in size with the availability of tobacco.¹⁰⁸ It would seem that reed pipes were not made in Malta on a commercial basis as more recent oral information suggests.¹⁰⁹ Mid-17th century CE quarantine registers show that over three quarters of the trade in tobacco products originated in Greece and the Aegean.¹¹⁰ Arrival Booklets for 1743-1747 in the National Archives of Malta Libretti confirm this pattern. In the 19th century there was still a lively trade with Constanti-

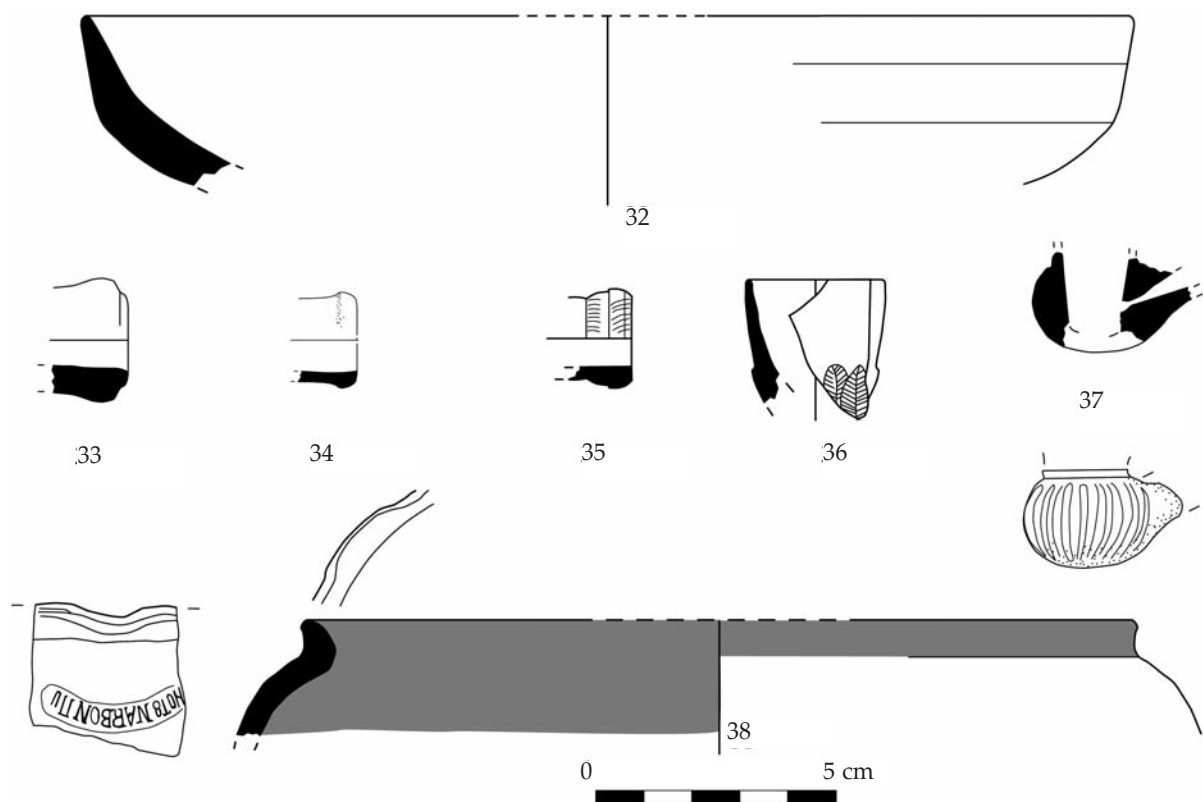

Fig. 26. Selected finds of the Early Modern period, Cat. 32 local bowl; Cat. 33-37 imported mould-made *pipa tal-qasba* or reed tobacco pipes; Cat. 38 Narbonnese spouted cooking pot (drawings: MSP, by RFD, digitised by Joris Angenon).

nople and Smyrna, attested in Lloyd Maltese Shipping Registers in the National Library. Heritage Malta and the Superintendence of Cultural Heritage already possess 349 chibouk style pipes, mostly in reserve collections. Many were from a wet environment.¹¹¹ The present collection from the survey may add significantly to our knowledge of this popular addiction.

Cat. 33: MSP2008/1/A119/P6/1, 1 end of shank fragment of mould-made tobacco pipe (fig. 26). Hard fired very pure light brown clay, discoloured grey towards the edges, with some very fine white rounded particles (less than 0.1 mm) and isolated sub-angular white particle (0.2 mm), surface grey (10 YR 6/1). PL 1.6, max. Diam. 2.6. Plain swelling with an incised groove under the terminal ring. Early Modern import.

Cat. 34: MSP2008/1/A41/P6/9, 1 end of shank fragment of mould-made tobacco pipe (fig. 26). Hard fired very pure red (10 R 5/6) clay with few very fine mica, surface light red (2.5 YR 6/4) slip or wash. PL 2.4, max. Diam. 2.0. Slightly swollen termination. Early Modern import.

Cat. 35: MSP2008/1/D44/P4/1, 1 end of shank fragment of mould-made tobacco pipe (fig. 26). Hard fired very pure red (2.5 YR 5/6) clay with isolated brown particle (0.1 mm), surface light red (2.5 YR 6/8). PL 1.3, max. Diam. 2.0. At first sight, the clay looks very much like that of ARS. The terminal ring has incised oblique decoration consisting of indents of rouletting in two rows, under which is a twist of rope work, both popular motifs. Early Modern import.

Cat. 36: MSP2008/1/F158/W110/1, 1 bowl fragment with plain burnished rim of mould-made tobacco pipe (fig. 26). Hard fired very pure light red (2.5 YR 6/8) clay with some very fine mica in the smoothed light red (2.5 YR 6/6) surface. PH 2.6, Diam. rim 3.0. At first sight, the clay looks very much like that of ARS. Decoration in relief consisting of two overlapping leaves. A similar motif was used to decorate a light brown bowl recovered from the quarantine harbour of Valletta as well as on an unpublished bowl and shank fragment found on the roof of a farmhouse at Is-Sruġ (Gozo).¹¹² The latter lichen covered object had been collected with other broken domestic pottery to be made into *deffun* (see above). Early Modern import.

Cat. 37: MSP2008/1/A57/P4/3, 1 bowl fragment of mould-made tobacco pipe (*fig. 26*).

Hard fired very pure reddish yellow (7.5 YR 6/6) clay with few red inclusions (0.1 mm), surface reddish yellow (7.5 YR 7/6). PH 3.1, Diam bowl 2.7, PL 3.3. Surface very much abraded; most of the rim, shank and base are missing.

Gadrooned decoration under a raised horizontal band. This style of pipe is well illustrated in contemporary paintings. One may, for example, mention Louis Ducros' watercolour of 'A group of young Gozitans dancing' (1778),¹¹³ Charles Brockdorff's 'Maltese pothouse' (1820),¹¹⁴ George Badger's 'Country man' (1838),¹¹⁵ and Michelle Bellanti's 'The New Aqueduct' (1843).¹¹⁶ Archaeologically, the style of decoration is found in many examples from Malta.¹¹⁷ Early Modern import.

Cat. 38: MSP2008/1/B82/P3/1, 1 rim fragment of Narbonnese spouted cooking pot (*fig. 26*).

Hard fired reddish brown (5 YR 5/4) clay with some sub-angular quartz, few white particles (0.2-0.3 mm) and some voids (0.2 mm), surface light reddish brown (5 YR 6/4) with red glaze (2.5 YR 4/8) on inside and upper part rim. PH 2.5, Diam. rim 17.0. Inversely stamped pottery mark below the spout, which may either read 'NOT8NARBONNE' or 'NO18NARBONNE'.

RFD, NC, CV, NCV, JW

SELECTED PHOENICIAN/PUNIC AND ROMAN POTTERY FROM THREE SURVEY TRACTS OF THE GEBEL GHAWZARA SITE

In the frame of the present preliminary report the ceramic study has focused upon the Phoenician/Punic and Roman finds of three specific tracts, belonging to the larger rural site of Gebel Ghawzara: MSP08/B16, MSP08/B21, and MSP08/B74 (*fig. 5*). The former two are situated in the area occupied by the agricultural installations of a Phoenician/Punic, Hellenistic and Roman to Late Antique farmstead/villa. The latter tract belongs to the garigue area just above the site itself and is situated due north of two graves dug into the bedrock (one of which illustrated in *fig. 16*).

TRACT MSP08/B16

Tract B16 has yielded 1125 finds, of which 31 are diagnostic fragments of the Phoenician/Punic and Roman periods. These consist mainly of Plain Wares (ca 45%), generally of local fabric, followed by local Cooking Wares (ca 19%) and local Red Slip Wares (ca 10%). Here, a representative selection of five fragments is published.

On the basis of the finds from this tract, the Middle Imperial period would constitute the latest occupation phase of the site during antiquity.¹¹⁸ It is documented by two poorly preserved fragments

of plates of African Red Slip Ware (ARS) of Hayes' types 16-18 (ca second half of the 2nd-first half of the 3rd century CE)¹¹⁹ and Hayes' types 2-18 (second half of the 1st-2nd century CE).¹²⁰ The fragments selected for the catalogue below allow distinguishing an Early Imperial occupation phase (*Cat. 43*), from a probably earlier, Late Hellenistic phase. To this latter phase one might attribute the base fragment *Cat. 42*, in addition to two small rims of plates with central well (such as *Cat. 53*) and two basins (such as *Cat. 55*).

The painted base *Cat. 39* and the possibly North Lucanian transport amphora *Cat. 41* may surely belong to a 4th-century BCE Punic phase of the site. The basin of Vegas' F.47.3 *Cat. 40* is likely to date back to a still earlier Phoenician/Punic phase.

Phoenician/Punic Period

Local Punic Painted Ware

Cat. 39: MSP2008/1/B16/General/1, 1 base fragment of a table amphora (*fig. 27*).

Hard fired, reddish yellow clay (5 YR 7/6), with many whitish microfossils (0.1-0.5 mm) and single yellowish bits (0.6 mm); light reddish brown (5 YR 6/4) painted horizontal lines externally on pale yellow slip (2 YR 8/4),

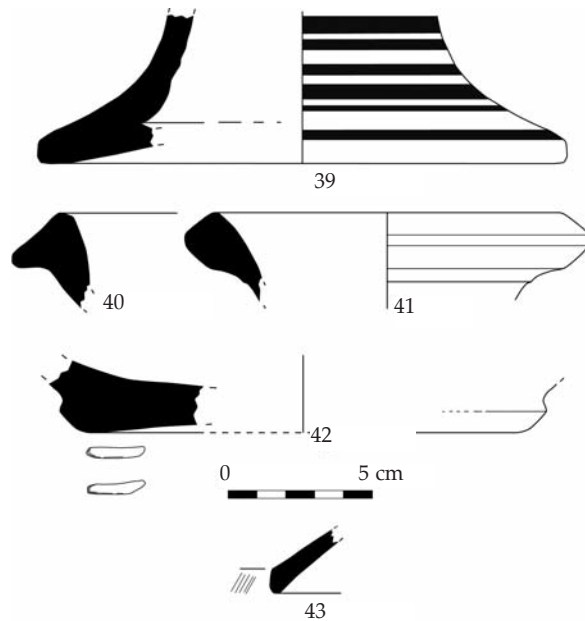

Fig. 27. Selected pottery from tract MSP08/B16: Phoenician/Punic period, Cat. 39 local painted table amphora; Cat. 40 local basin; Cat. 41 North Lucanian (?) transport amphora; Hellenistic period, Cat. 42 local basin; Roman period, Cat. 43 African Blacktop Ware lid (drawings: MSP, by BB, digitised by Joris Angenon).

colour of internal surface reddish yellow (5 YR 7/6); traces of mortar on surface. PH 5.2, Diam. base 17.8. *Cat. 39* matches Sagona's form III-IV:4a-b of the urns, characteristic of her later phase III-early phase IV, that is to say 410-300 BCE.¹²¹ According to E. Groenewoud and P. Vidal González this 'two-handled jar' might be considered a '(...) typical Central Mediterranean shape, possibly of Maltese origin'.¹²² Its distribution along the geographical axes Malta - Sicily - Balearic islands has been discussed by Ciasca.¹²³ The very recent study of the Maltese pottery yielded by the German-Italian mission at Pantelleria has shown that urns of Sagona's type III-IV:4a-b represent by far the most common shape within the finds from both the acropolis excavations and the survey.¹²⁴

Local Plain Ware

Cat. 40: MSP2008/1/B16/BS7/1, 1 rim fragment of a basin (*fig. 27*).

Hard fired, dark reddish grey clay (5 YR 4/2), with many whitish microfossils (0.1 mm), some grey stony bits (0.5-1.5 mm) and rare red inclusions (0.3 mm); on surface pink-reddish yellow slip (5 YR 7/6 - 7/4). PH 3.3, Diam. rim ?

Cat. 40 is likely to belong to a basin as M. Vegas' Form 47.3, documented in the settlement of Carthage from the second half of the 8th to the first half of the 5th century BCE.¹²⁵

Transport Amphora North Lucanian fabric?

Cat. 41: MSP2008/1/B16/P7/2, 1 rim fragment of an amphora of Vanderersch's type III (*fig. 27*).

Hard fired, coarse, clay, reddish yellow on exterior (5 YR 6/6), pink on interior (7.5 YR 7/4), with quite a lot of roundish violet, iron grits (1.0 mm), frequent angular blackish volcanic inclusions (0.1-0.3 mm) and quartz (0.5 mm) and some microfossils (0.3 mm); pink slip (5 Y 8/3) inside and outside. PH 3.2, Diam. rim 12.

The type may be attributed to amphorae of type MGS III by Ch. Vanderersch.¹²⁶ The oldest specimens come from late 5th- and first half of the 4th-century BCE contexts, but the bulk of the vessels of this shape was almost certainly produced after the middle of the 4th century BCE.¹²⁷ The best morphological comparisons for *Cat. 41* of presumably Lucanian fabric come from Sicily. On Lipari the type '*con orlo ad echino*' is dated to the second half of the 4th and the beginning of the 3rd centuries BCE.¹²⁸ In Entella, MGS amphorae similar to *Cat. 41* have been found in the '*edificio granario*', in a context dated to the last quarter/end of the 4th century BCE.¹²⁹ One further parallel has been found on a rural site close to Camerina ('*fattoria delle api*').¹³⁰

A sample of the present fragment appears to be similar to an amphora fabric attributed to Paestum,¹³¹ but the presence of clearly volcanic inclusions in the fabric of *Cat. 41* distinguish it from the production of Poseidonia. The documentation of a vessel possibly from the North Lucanian area on Malta would be highly interesting, since transport amphorae from Northern Lucania (Velia and Paestum) are apparently very well documented on other 4th-century BCE Punic sites of the cen-

tral Mediterranean area (Jerba, Carthage, Pantelleria, Selinunte).¹³²

One may conclude that the Phoenician/Punic and Roman finds from Tract B16 date to the 4th century BCE till at least the 2nd century or first half of the 3rd century CE.

Hellenistic Period (Late Hellenistic: 2nd-1st Century BCE)

Cat. 42: MSP2008/1/B16/BS13/7, 1 base fragment of a basin (*fig. 27*).

Hard fired, gritty clay, light red at core (2.5 YR 6/8), weak red on surface (2.5 YR 5/2), with many whitish microfossils (0.5 mm) and rare black grits (0.4-0.5 mm); traces of pink slip (5 YR 8/3) on surface; two radial lines, incised before firing, on underside of the resting surface. PH 2.5, Diam. base 14-15.

Roman Period (Early Imperial: late 1st Century BCE-1st Century CE)

African Blacktop Ware

Cat. 43: MSP2008/1/B16/BS7/2, 1 rim fragment of a lid of Fulford's type 10 (*fig. 27*).

Hard fired, fine, light red clay (2.5 YR 6/8), reddish yellow (5 YR 7/6) on surfaces, rim externally blackened, with tiny bits of quartz. PH 2.3, Diam. rim ?

Cat. 43 may be compared to an African Black Top lid of Fulford's type 10, first documented in the late 1st century BCE, but occurring more frequently in the 1st century CE down to the 4th century CE.¹³³

TRACT MSP08/B21

Tract MSP08/B21 has yielded 627 pottery fragments, of which 111 diagnostic ones belonging to the Punic and Roman periods have been studied by the present author. The quantitative distribution of the single ceramic classes within this selection of diagnostic fragments shows that Plain Wares, mainly of supposed local fabric, prevail with nearly 58%, followed by transport amphorae (10%), which are almost exclusively of imported fabrics, and local Handmade Wares (10%), generally red slipped (*fig. 28*).¹³⁴

The sixteen items included in the catalogue below have been selected with the intention of illustrating the different occupation phases of the site in antiquity. There is scarce evidence for occupation of the site during the Middle and Late Imperial period: a presumably Tunisian amphora (*Cat. 57*), one vessel of the class 'Forlimpopoli' (*Cat. 58*) and a possibly local red slipped bowl (*Cat. 59*). Even less strong is the evidence for the Early Imperial phase, represented by a single Italian Terra Sigillata fragment (*Cat. 55*), in addition to a Campanian Dressel 2-4 amphora (*Cat. 56*).

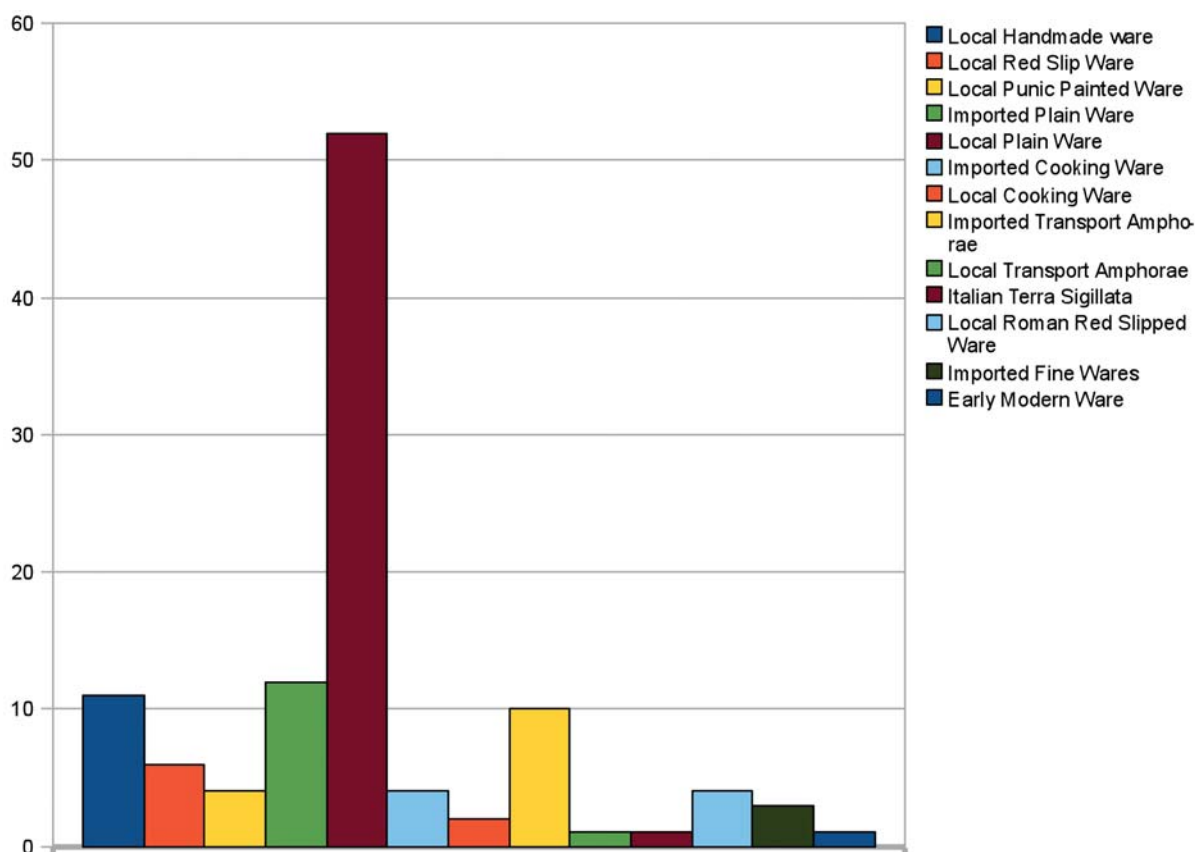

Fig. 28. Quantitative distribution of the ceramic classes within the material collected on tract MSP08/ B21 (N=111 diagnostic fragments considered; prepared by BB).

Best documented, however, is the phase of the Late Hellenistic period (2nd-1st century BCE), with characteristic associations between transport amphorae imported from the wine-producing regions of Campania (Cat. 47) and the Adriatic area (Cat. 48), a fish-sauce amphora from Baetica (Cat. 50), together with a local amphora of class 'Malta 1' (Cat. 49) and some highly diagnostic Plain Wares shapes (Cat. 51-54).

There is also some evidence for occupation during the Phoenician/Punic period, which is indicated mainly by a few fragments of local Punic Painted Ware (Cat. 45) and an imported table amphora (Cat. 46), in addition to six items of Red Slip Ware of the Phoenician/Punic period (Cat. 44).

In conclusion, Tract B21 shows an occupation, apparently without any interruption, from a still undetermined moment during the Phoenician/Punic period (second half of the 4th century BCE at the latest) down to the 2nd or 3rd century CE.

Phoenician/Punic Period (earlier than the 2nd Century BCE)

Local Punic (?) Red Slip Ware

Cat. 44: MSP2008/1/B21/BS11/49, 1 rim fragment of a bowl (fig. 29).

Hard fired, reddish yellow clay (5 YR 6/6), with some white grits (0.5 mm), some greyish, angular shaped, stony particles (0.8 mm) and some blackish-reddish inclusions (0.5 mm); surfaces smoothed and covered by a reddish yellow slip (5 YR 7/8). PH 2.6, Diam. rim 22. The presence of a few fragments of apparently local Red Slip Ware on Tract B21 hints at the possible occupation of the site already during the Phoenician/Punic (Early Punic) period, a fact also corroborated by the finds on other parts of the wider Gebel Ghawzara site. Cat. 44 seems to be close to Peserico's type CsC1, particularly sub-type III, which at Carthage in particular is attested in deposits dated to the advanced 8th-early 7th century BCE.¹³⁵

Local Punic Painted Ware

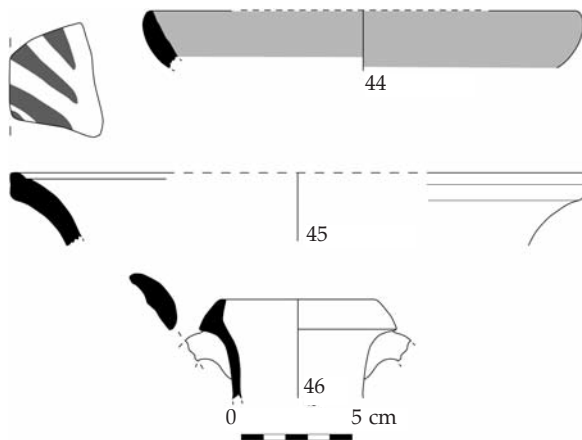

Fig. 29. Selected pottery of the Phoenician/Punic period from tract MSP08/B21: Cat. 44 local Red Slip bowl; Cat. 45 local Painted Ware basin; Cat. 46 Sicilian (?) table amphora (drawings: MSP, by BB, digitised by Joris Angenon).

Cat. 45: MSP2008/1/B21/BS12/12, 1 rim fragment of a basin (fig. 29).

Hard fired clay, very pale brown on exterior and interior (7.5 YR 5/2), pale brown at core (10 YR 6/3), with some brown, roundish particles (0.3 mm) and some yellow inclusions (0.5-1 mm); thick, high quality, pale scum (10 YR 8/3) on surfaces, painted with red (10 R 5/6) leaves on the interior. PH 3.3, Diam. rim range 26-28. While the particular profile of Cat. 45 remains - so far - without comparisons, the presence of a thick, high quality pale slip on the surfaces of the item hints at a dating to within the 4th-3rd century BCE, when the local pottery productions appear to be frequently characterised by this particular surface treatment.¹³⁶ More or less comparable decorations have been published from the San Pawl Milqi villa.¹³⁷ The rare presence of reddish painted leaves or flowers on Maltese pottery dating to this period has already been noted by Ciasca.¹³⁸

Imported Plain Ware (Sicily?)

Cat. 46: MSP2008/1/B21/BS11/43, 1 fragment of rim and handle attachment of a table amphora (fig. 29).

Hard fired, very fine, light reddish brown clay (5 YR 6/4) with some tiny whitish and greyish bits; on surface traces of a pink slip (5 YR 8/3)? PH 4.5, Diam. rim 6.8. Cat. 46 is likely to belong to a table amphora with triangular rim, characterised by an internally concave profile and cylindrical neck. This type, often with painted decoration, appears to be well documented in northern Tunisia (Cap Bon, Kerkouane, Carthage), western Sicily (Segesta, Entella, Lilybaeum) and Punic Sardinia. The stratified evidence derived from recent excavations suggests an occurrence mainly covering the second half of the 4th and the first half of the 3rd centuries BCE, in Sardinia possibly during the whole 3rd century BCE.¹³⁹

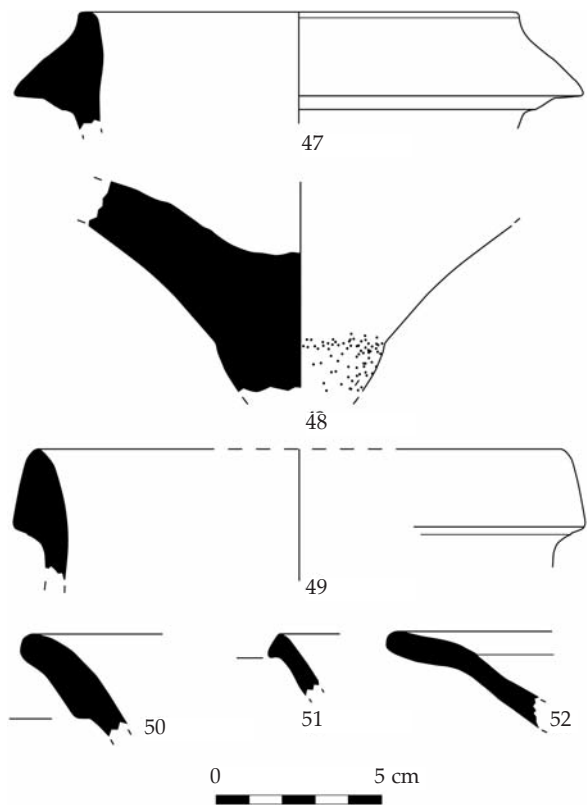

Fig. 30. Selected pottery of the Hellenistic period from tract MSP08/B21: Cat. 47 Campanian Graeco-Italic transport amphora; Cat. 48 Adriatic transport amphora; Cat. 49 local transport amphora; Cat. 50 southern Iberian transport amphora; Cat. 51 local plate or bowl; Cat. 52 local plate (drawings: MSP, by BB, digitised by Joris Angenon).

Hellenistic Period (Late Hellenistic: 2nd-1st Century BCE)

Transport Amphorae

Campanian Fabric

Cat. 47: MSP2008/1/B21/BS11/1, 1 rim fragment of Graeco-Italic amphora of Vandermersch's MGS VI (fig. 30).

Hard fired, reddish yellow clay (5 YR 6/6), with rare bits of quartz (0.1 mm) and whitish particles (0.3 mm, limestone?), abundant reddish inclusions (0.5 mm) and a good number of black (volcanic) particles (0.3-0.6 mm); on internal and external surface very pale brown slip (10 YR 8/3). PH 3.5, Diam. rim 13.2.

A sample taken from Cat. 47 resembles H. Liko's 'Scherbentyp' AH 13 of the Hellenistic amphorae from Velia, which is attributed to the Gulf of Naples.¹⁴⁰

From a morphological point of view, the present item corresponds to an advanced, late 3rd-early 2nd-century BCE evolution stage of the series of the Graeco-Italic amphorae.¹⁴¹ Good typological comparisons can be found among the transport vessels forming the cargo of the Ses Lloses-Lazareto wreck (Menorca), dated to within the late 3rd century BCE,¹⁴² and from a deposit excavated at Ampurias of the first quarter of the 2nd century BCE.¹⁴³ Furthermore, layer IIIA-B of the excavations in the settlement of Tindari (northern Sicily), dated to around 200 BCE, has yielded more comparisons.¹⁴⁴

Amphorae of this type and similar to *Cat. 47* have been published from Malta before, in archaeological deposits of the 'area nord' of the Tas-Silġ sanctuary, dated to within the Late Republican period.¹⁴⁵ The present survey has yielded a slightly earlier Graeco-Italic amphora of Vanderersch's type MGS V/VI that may have been produced on eastern Sicily (MSP2008/1/C36/P1/3).
Adriatic Fabric

Cat. 48: MSP2008/1/B21/F1/1, 1 base fragment of an amphora type Lamboglia 2/Dressel 6A (*fig. 30*). Hard fired, quite fine, pink clay (7.5 YR 7/4), with some greyish bits of quartz (0.3 mm), some red particles (0.3-0.5 mm) and tiny bits of golden mica. Pinkish slip (7.5 YR 8/4) on inside and outside. PH 5.7, max. Diam. base 11.5.

The poor preservation of *Cat. 48* does not allow a precise attribution to one of the two consecutive Adriatic forms. The Adriatic series have been produced from the second half of the 2nd century BCE up to the middle of the 1st century CE,¹⁴⁶ and appear to be well attested in both the sanctuary of Tas-Silġ and the villa of San Pawl Milqi.¹⁴⁷ Also the survey has yielded fragments of these amphorae in some numbers.

Maltese Fabric

Cat. 49: MSP2008/1/B21/W2/2, 1 rim fragment of an amphora of class 'Malta 1' (*fig. 30*). Hard fired, reddish yellow clay (5 YR 6/6), with abundant particles of quartz and many roundish, yellow inclusions (0.5-1 mm). PH 3.9, Diam. rim 15.4.

Cat. 49 seems to match both the morphological and technical characteristics of the class 'Malta 1', identified by Bruno and C. Capelli.¹⁴⁸ The production of this hybrid, local type that imitates several non-local forms (such as Lamboglia 2, 'anfore di Brindisi', 'anfore tripoli-

tane antiche'), dates to within the late 2nd and 1st century BCE.

Southern Iberian Fabric (Baetica?)

Cat. 50: MSP2008/1/B21/P1/2, 1 rim fragment of an amphora of type Dressel 9 (*fig. 30*).

Hard fired, reddish yellow clay (5 YR 6/6), with some quartz (0.2 mm) and many whitish inclusions (stone, 0.3 mm); very pale brown slip (10 YR 8/3) inside and outside. PH 3, Diam. rim ?

From a morphological point of view, *Cat. 50* seems to belong to an early Iberian fish-sauce amphora of Dressel's type 9, dating possibly to within the second half of the 1st century BCE,¹⁴⁹ even if the fabric of the southern Iberian series appears to be normally of a characteristic greenish colour.¹⁵⁰ The evidence from Carthage shows, however, that more fabrics of Dressel 9 amphorae are attested.¹⁵¹ Transport amphorae from Baetica occur in small numbers among the finds from the Italian excavations at Tas-Silġ.¹⁵²

Local Plain Wares

Cat. 51: MSP2008/1/B21/P2/6, 1 rim fragment of a plate or bowl (*fig. 30*).

Hard fired, yellowish red clay (2.5 YR 6/8), reddish yellow on surfaces (5 YR 7/6), with many whitish microfossils (0.2 mm); on surface traces of mortar. PH 1.8, Diam. rim ?

Cat. 51 seems to belong to a quite frequent shape of plate with central depression, documented at Malta in deposits dating to within the second half of the 2nd, the 1st century BCE and the 1st centuries CE.¹⁵³ Although both Sagona and Quercia call this shape a 'plate', the deep profiles of these vessels seem to warrant the application of the term 'bowl' as well.

Cat. 52: MSP2008/1/B21/BS7/21, 1 rim fragment of a plate (*fig. 30*).

Hard fired, very dark grey (7.5 YR 3/), overfired clay, probably with some bits of quartz and some voids (0.2-0.4 mm); on surface rests of a light grey (10 YR 7/2) scum? PH 2.9, Diam. rim ?

Cat. 52 is likely to be attributed to a plate close to Quercia's types 3 (4th-3rd century BCE)¹⁵⁴ or 14-15 (from the 2nd century BCE onwards).¹⁵⁵

Cat. 53: MSP2008/1/B21/BS11/7, 1 rim fragment of a basin (*fig. 31*).

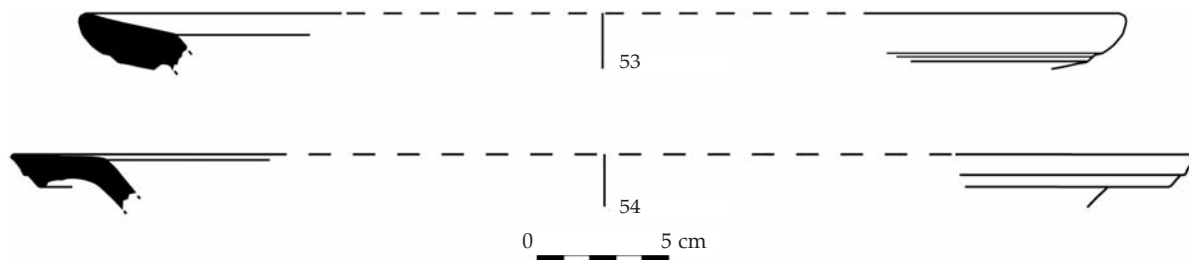

Fig. 31. Selected pottery of the Hellenistic period from tract MSP08/B21: Cat 53-54 local basins (drawings: MSP, by BB, digitised by Joris Angenon).

Hard fired clay, grey on exterior and interior (5 YR 5/1), reddish yellow at core (5 YR 6/6), with many white particles (0.3-0.5 mm) and some grey inclusions (0.3 mm); pink scum (7.5 YR 8/4) on surfaces; calcareous incrustations on part of the surface. PH 2.1, Diam. rim > 40.

Two almost identical items come from Tract B16 (MSP2008/1/B16/BS13/6 and MSP2008/1/B16/P4/2), which is in fact two fields (tracts) lower than B21; also Tract A25 in the survey yielded a comparable rim (MSP 2008/1/A25/P10/3). For a discussion on the chronology of a similar vessel ('large platter/dish') one may refer to *Cat. 16* (*fig. 22*), above.¹⁵⁶

Cat. 54: MSP2008/1/B21/BS12/16, 1 rim fragment of a basin (*fig. 31*).

Hard fired clay, light red on exterior and interior (2.5 YR 6/8), weak red at core (2.5 YR 5/2), with many black grits (0.1-0.2 mm) and single brownish yellow, roundish inclusions (0.2-0.4 mm); light grey (2.5 Y 7/2 – 10 YR 7/2) scum on surfaces. PH 1.9, Diam. rim 47.

Cat. 54 matches Quercia's type 11 of the basins documented at Tas-Silġ; it is attributed to the Late Republican and Early Imperial period, but possibly already in use from the 3rd century BCE onwards.¹⁵⁷ A comparison from a disturbed context in Tas-Silġ (room/altar 38), containing local Late Punic pottery of the Hellenistic period, has been dated slightly earlier than the 1st century BCE/1st century CE.¹⁵⁸ Tract B21 has yielded a second item of this shape (B21/BS11/6).

Roman period (Early Imperial: Late 1st Century BCE - 1st Century CE)

Italian Terra Sigillata

Cat. 55: MSP2008/1/B21/BS1/17, 1 base fragment of plate (*fig. 29*).

Very hard fired, very fine pink clay (5 YR 8/4), with many tiny voids; red slip inside and outside (2.5 YR 4/8). Incised concentric circle, surrounded by rouletting on tondo. PH 2.3, Diam. base 11.

Cat. 55 may be attributed to a plate of the types Consp. 6.4-5, Consp. 19.3 or Consp. 21.5-8, all more or less datable to within the second quarter and the middle of the 1st century CE, with single items circulating still during the Flavian period.¹⁵⁹

Transport amphora

Campanian Fabric

Cat. 56: MSP2008/1/B21/F1/17, 1 rim fragment of an amphora of type Dressel 2-4 (*fig. 32*).

Hard fired, light red clay (2.5 YR 6/6), with abundant black (volcanic) particles (0.5 mm); on internal and external surfaces very pale brown slip (10 YR 8/3). PH 5, Diam. rim 10.4.

This extremely widespread type has been exhaustively discussed by many authors.¹⁶⁰ It derived from the late Hellenistic Coan series and was imitated in many wine-producing areas around the Mediterranean from the late 1st century BCE. At Carthage, Campanian Dressel 2-4 amphorae are mainly documented to within phase I

(40/20 BCE-30 CE).¹⁶¹ The data collected by Bruno show that on Malta these amphorae are clearly less well-represented in comparison to the earlier amphorae of the Dressel 1 type from the same production area.¹⁶²

Roman Period (Middle Imperial: 2nd-3rd Century CE)

Transport amphorae

North African fabric (Tunisia?)

Cat. 57: MSP2008/1/B21/BS5/8, 1 rim fragment of an amphora of Bonifay's type 18 (*fig. 32*).

Hard fired, red clay (2.5 YR 5/6), with many white grits (foraminifera? 0.1-0.2 mm) and some voids (0.2 mm); pale yellow slip (2.5 Y 8/4) inside and outside. PH 4.4, Diam. rim ?

Cat. 57 belongs to a large group of possibly Tunisian, not yet standardized amphorae originating in several production centres that were active within the 1st and 2nd centuries CE.¹⁶³ In his classification of the North African amphorae, M. Bonifay has described these probable fish-sauce containers as type 18.¹⁶⁴ The present item finds a good comparison in an amphora of local fabric found on the site of Bir Abbad (Ksour Essaf region, Tunisia), and apparently associated with vessels of the Africana IIA type 'senza gradino', dating to the 2nd-3rd century CE.¹⁶⁵ One more parallel comes from Uzita/Uzitta.¹⁶⁶

Northern Adriatic Fabric

Cat. 58: MSP2008/1/B21/BS9/4, 1 handle fragment of an amphora of the 'Forlimpopoli' type? (*fig. 32*).

Hard fired, white clay (2.5 Y 8/2), on surface white (5 Y 8/2), with many whitish stony particles (0.2-0.4 mm) and some voids (0.2 mm). PH 2.6, Diam. neck 7.

The handle fragment *Cat. 58* may be attributed to an amphora of the so-called 'Forlimpopoli' class, a series of wine containers with flat bottom, produced in the Emilia region from the second half of the 1st century CE for about two centuries. It has been documented on North African sites as Berenice/Benghazi as well.¹⁶⁷

Local Slipped Ware

Cat. 59: MSP2008/1/B21/P6/16, 1 rim fragment of a bowl (*fig. 32*).¹⁶⁸

Hard fired clay, brown on exterior and interior (7.5 YR 5/2), reddish yellow at core (5 YR 6/6), with many black grits (0.2 mm) and abundant microfossils (0.2-0.5 mm); reddish yellow slip outside, the dark grey (5 YR 4/1) slip of the internal surface appears to be misfired. Traces of mortar on external surface (from secondary use). PH 2.8, Diam. rim 30.8.

Cat. 59 may well correspond to Sagona's 'Local Red Ware' of the Roman Imperial period.¹⁶⁹ The present fragment seems to imitate the African Red Slip series, and particularly variant 8B of Hayes' classification, dating to the second half of the 2nd or first half of the 3rd century CE.¹⁷⁰

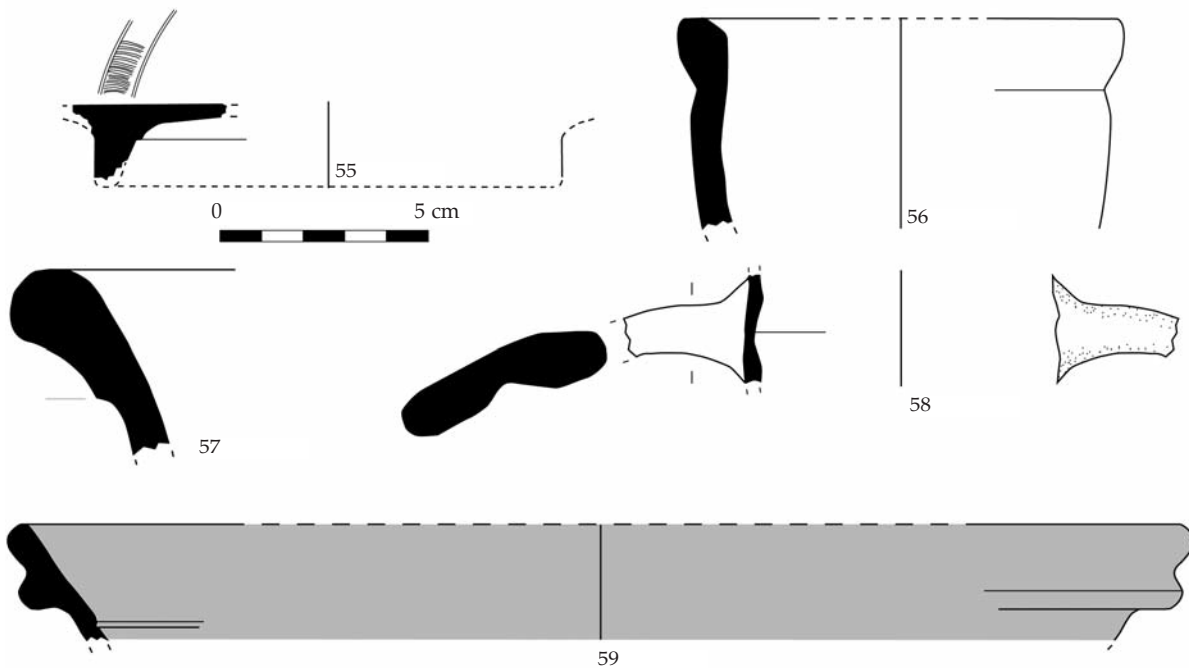

Fig. 32. Selected pottery of the Roman period from tract MSP08/B21: Cat. 55 Italian Terra Sigillata plate; Cat. 56 Campanian transport amphora; Cat. 57 North African transport amphora; Cat. 58 northern Adriatic transport amphora; Cat. 59 local slipped bowl (drawings: MSP, by BB, digitised by Joris Angenon).

TRACT MSP08/B74

Tract B74, which is part of the garigue plateau of the Ġebel Ġhawżara site to which Tracts B16 and B21 belong (fig. 5), has yielded 35 finds. Nine diagnostic fragments may be connected to the site's occupation during the Phoenician/Punic (see *Cat. 60*) and (Late) Hellenistic (see *Cat. 61*) periods.¹⁷¹ Especially the lamp *Cat. 60* is suggestive of the fact that this Phoenician/Punic material found on top of the garigue plateau may be interpreted as material dumped after the excavation of graves at the edge of the garigue, probably sometime in the 19th or early 20th century CE (see above, and fig. 16).

Phoenician/Punic Period (4th-3rd Century BCE)

Imported (?) Plain Ware

Cat. 60: MSP2008/1/B74/P4/1, 1 fragment forming the profile of a lamp of Deneauve's type VII/VIII (fig. 33). Hard fired, light reddish yellow clay (7.5 YR 6/6), with many whitish inclusions (0.2 mm) and some voids (0.2 mm); on surface rests of white slip (5 Y 8/2). H 2.7, Diam. rim 7, Diam. base 3.8. Lamps of this particular shape are not infrequently encountered in Maltese grave contexts. In fact, *Cat. 60* seems to match the lamp shapes characteristic of Sa-

gona's phase IV, that is to say ca 300-100 BCE.¹⁷² At Carthage, the latest variants of the ancient Phoenician double-spouted lamp shape of Deneauve's type VII/VIII only occur in the cemeteries and are attested in grave contexts dating to the 4th and 3rd centuries BCE.¹⁷³

The Ħal Millieri site in south-eastern Malta yielded a similar lamp of a 'fairly coarse orange-brown fabric with small sand inclusions and occasional fissures', considered to be local.¹⁷⁴ It is dated to the Medieval period or later, probably till the mid-17th century CE. A similar lamp from Gozo has also been dated to the Early Modern period.¹⁷⁵ Also in archaeological collections on (western) Sicily similar lamps of later date may be found. Although these lamps are morphologically very similar to the Punic examples mentioned above as comparisons, the fact that with the present piece we are dealing with a probable import, the fact that about 75% of the finds on tract B74 date to the Phoenician/Punic and Hellenistic/Roman periods, and the relation with the emptied graves nearby, make a strong case for considering *Cat. 60* as a Punic piece.

Hellenistic Period (Late Hellenistic: 2nd-1st Century BCE)

Local Plain Ware

Cat. 61: MSP2008/1/B74/P3/1, 1 fragment of rim of a basin (fig. 33). Hard fired, light reddish yellow clay (5 YR 6/6, 5 YR 7/6 on surfaces), with many yellowish inclusions (micro-

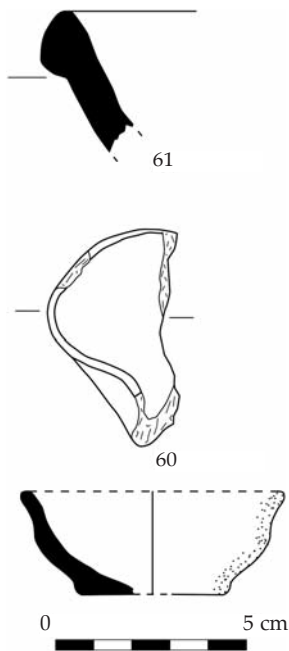

Fig. 33. Selected pottery of the Hellenistic period from tract MSP08/B74, Cat. 60 imported (?) lamp; Cat. 61 local basin (drawings: MSP, by BB, digitised by Joris Angenon).

fossils? 0.2-0.4 mm) and some voids (0.2 mm). Traces of mortar on the outside. PH 3.7, Diam. rim ?

Cat. 61 of presumably local fabric might be considered an imitation of an extremely frequent shape of the 'Pompeian Red' Ware, that is to say the basin with almond-shaped rim. Recent research on Sicily has shown that this type is well attested to within 1st-century BCE levels.¹⁷⁶

BB

INTERPRETATION OF THE MSP2008 DATA (2008-2010)

The results of the 2008-2010 survey campaigns in north-west Malta have considerably enlarged our understanding of rural Malta through the ages. If one looks at the data available for the wider area in 2008 (fig. 3), it is clear that the previous and less systematic archaeological exploration mainly centred upon the rich and monumental Prehistoric period of the island, with the Phoenician/Punic and Hellenistic/Roman periods taking a more modest second place. The systematic approach of the present survey has clearly balanced the diachronical picture.

The human presence in prehistoric times seems well attested by finds, dispersed over the survey area, of lithic material (Cat. 1-3, fig. 18) as well as ceramic finds of the Bronze Age (Cat. 4-5, fig. 19). That the fragment of a Temple period (carinated) bowl (Cat. 4, fig. 19) has been found just below the escarpment of a garigue plateau may not be coincidental, but may effectively hint at the human occupation pattern of the landscape during the

second half of the 3rd millennium BCE.

The first securely datable finds from the 1st millennium found in the survey (at least in the part studied up to this moment) date to the 6th or 5th century BCE (cf. the rock cut tomb, fig. 16), or more precisely the last quarter of the 6th and first quarter of the 5th century BCE (Cat. 6, fig. 20). Some finds, however, seem to suggest earlier dates (Cat. 7-8, fig. 20, and Cat. 44, fig. 29). The fact that in the case of Cat. 6 we are dealing with an imported Corinthian olive oil container may perhaps be suggestive of an agricultural regime at the time that (still) was not based upon a (sufficient) production of olive oil. The find was made in a tract close to and perhaps belonging to the wider Tal-Ghazzi site.

The seminal article of D. Locatelli on the oil production of the San Pawl Milqi site has clearly shown that the Roman villa estate must have controlled an area in the range of 10 to 14 hectares during 'periodo VI' of Locatelli (second quarter of the 3rd century to the late 3rd or beginning of the 4th century CE), producing a yearly yield of 7,500 to 14,000 kg of oil.¹⁷⁷ If the intermediate distances of the sites are taken into account and one assigns each estate a territory that reaches at least to the valley bottom, one may indeed arrive at estates of about 10 to 14 hectares. At least two of the three sites seem to have been characterised by the (abundant and constant) presence of water, whereas the San Pawl Milqi site seems to have been served by a large cistern, dated to 'periodo II' of Locatelli. In the case of the Gebel Ghawzara site this may even have led to the installation of a thermal bath in the (Late) Roman period, if the evidence from the Ground-Penetrating Radar survey (see above, fig. 17) on tract B55 may be interpreted in this way.

As to the early chronology of these agricultural installations, the study of the finds from the area seems conclusive. All three sites have given clear evidence of human presence, viz. occupation, during the Punic period, more particularly the 5th, 4th and 3rd centuries BCE (but see also the comments on Cat. 40, fig. 27). The general dating of the earliest Punic occupation of the San Pawl Milqi site, as suggested by the Italian mission (the 4th or 3rd century BCE) seems at least confirmed by the preliminary study of some of the finds from the adjacent fields (see e.g. tract C181, Cat. 9; fig. 20). This phase of the site's occupation ('periodo II') in the scheme recently worked out by Locatelli is connected with channels and basins hewn out in the bedrock (now visible below the church) that may tentatively be connected with the production of

olive oil on a reduced scale.¹⁷⁸ A cistern may also be connected to this early phase.

The first coherent architectural remains at the San Pawl Milqi site belong to phase III ('periodo III'), dated to the late Republican period.¹⁷⁹ The evidently rural villa site has a large, oblong rectangular structure, detached from the main square building centred around a courtyard, that resembles the oblong rectangular building seen in the GPR-images of tract B55 (*fig. 17*). It may well have been a large barn for the storage and processing of agricultural products.¹⁸⁰ Locatelli has advanced evidence for the application of a Punic modular measuring system in the construction of the buildings of this phase that can also be seen in use in the North African (former) Punic territory.¹⁸¹

Although architecturally we do not have any hard evidence at hand for settlement in the area before the 1st century BCE (San Pawl Milqi; but see *Cat. 23, fig. 24*), the study of the finds and the rock-cut tomb (*fig. 16*) would firmly imply a 6th-/5th-century occupation of the landscape of a permanent nature and of a considerable scale (but see on possibly earlier dates, above). Pending excavation of some of the structures of probable Phoenician/Punic date found in the GPR survey on tracts B21 and B55, one may already postulate the idea that the three sites distinguished in the survey form the continuation of sites inhabited in the 6th/5th century BCE. Since no clear finds dating to the centuries before this period have been distinguished among the 29,309 finds studied (but see above), one may perhaps conclude that this postulated Phoenician/Punic settlement pattern in fact only came into existence in the (late) 6th or (early) 5th century BCE. One would then probably be witnessing a managed landscape of the transitional Early Punic/Middle Punic period (expressed in Carthaginian chronological terms), that seems to be a good reflexion of what is happening in North Africa and elsewhere in the central and western Mediterranean.¹⁸² A direct Carthaginian economic and political involvement would, then, not be impossible, although a system of cash-cropping of oil already for this early period would seem very unlikely.¹⁸³

In this connection one should also return to the odd geographical position of Malta's main urban centre of the Phoenician/Punic period at Rabat/Mdina, mentioned in the introduction. A position so far removed from the coast is without precedent within the Phoenician/Punic colonial record of the 8th and 7th centuries BCE; coastal sites are the rule. It has long been known that the present-day Salini district, situated in the north part of the

survey transect (see *fig. 2*, cf. *fig. 4*), are the remains of a far larger inner bay that may have reached as far inland as lower slopes of the Ġebel Ġhawżara (if not farther).¹⁸⁴ Although the (gradual) silting up of this large area of marshland has not yet been dated, one may suggest that it post-dates the Phoenician/Punic period. Following the conventional Phoenician/Punic colonial settlement pattern, strongly focussed upon coastal headlands, and preferentially using existing natural inner bays for shelter, one may speculate on the position of an early Phoenician/Punic colonial establishment around the inner bay, perhaps below the modern urban centre of Buġibba/Qawra, or farther south along the foothills that will be explored in a forthcoming survey campaign, scheduled for the year 2012 (see *figs 2, 4*). In this line of reasoning, the central site of Rabat/Mdina would then have formed the main centre of an already existing Maltese population, in contact with this postulated Phoenician/Punic centre near the coast, and consequently heavily influenced by it, to a level where one would consider the site to be Phoenician/Punic itself.

The three sites distinguished in the survey seem to have continued either uninterrupted or with interruption - after a serious destruction as in the case of the San Pawl Milqi site at the end of 'periodo VI' of Locatelli - into the Late Antique period and the Early Medieval period (see *figs 12-13*), as also witnessed by the study of the finds. The distribution map of the High Medieval period (*fig. 14*), admittedly still incomplete, seems to suggest already a different settlement pattern for this part of Malta. A more detailed discussion of this period and the successive ones, however, lies outside the scope of the present preliminary report on the Malta Survey Project.¹⁸⁵

RFD, NCV, NC, AB, AP

NOTES

¹ The investigations have been made possible from the Belgian side by generous support of the Fund for Scientific Research Flanders (Belgium: FWO-Vlaanderen; project grant reference G.0162.06N). An initial reconnaissance was held in 2007 by Lieven Verdonck (LV), and again in 2008 by geomorphologist Morgan De Dapper (MDD). The team in 2008 consisted of the following: Maxine Anastasi (MA), Babette Bechtold (BB), Chris Busuttill, Evelyne Browaeys, Robert Caruana, Nathaniel Cutajar (NC), Marvin Demicoli, Alain De Wulf (ADW), Guy Dierkens (GD), Roald Docter (RFD), Dagmar Geronprez, Steven Hast, Boutheina Maraoui Telmini (BMT), Timothy Nuttens (TN), Michelle Padovani, Sophie Mortier, Iona Muscat, Thomas Pieters, Stephanie Said, Kwan Jau Siu, Jen Smets, Mevrick Spiteri (MS), Anke Thuy, Winfred van de Put (WvdP), Thomas Van de Velde,

- Caroline Van Hecke, Maria Vella, Nicholas Vella (NCV), Ann Verbruggen, LV, and Renata Zerafa (RZ). The team in 2009 consisted of the following: MA, BB, Thomas Blicke, Chris Busuttill, Juan Correa Cáceres, NC, Luisana D'Amato, Elysia Marie Darmanin, Bart Deprez, ADW, GD, RFD, Soumaya Garsallah (SG), Rudi Goossens (RG), Liesbeth Hermans, Michelle Padovani, Rebecca Farrugia, BMT, Jihène Nacef (JN), Xavier Ruiz I Cano (XRIC), Stephanie Said, Jessica Spiteri, MS, WvdP, Maria Vella, NCV, LV, and Abigail Zammit. The team in 2010 consisted of the following: MA, Mark Attard, BB, Karl Cachia, Chantal Marie Cassar, Eve Cocks, NC, Elysia Marie Darmanin, Bart Deprez, Raissa Deguara, GD, RFD, Liesbeth Hermans, Narcisse Merlier, Michelle Padovani, Stephanie Said, Jessica Spiteri, Tiffany Lizen, WvdP, and NCV. The Project is also grateful to the tenant farmers or landowners who allowed us free access to their fields and for providing us with useful snippets of information related to the fields they till. The present contribution is based upon a conference contribution of 2009 (Vella et al. forthcoming), which is largely reworked, expanded and updated; see also De Wulf et al. forthcoming.
- 2 When possible, distinction is made between 'Phoenician' and 'Punic', following the general practice within the discipline: 'Phoenician' for the earliest phase of the westward colonial expansion and 'Punic' for the chronological phase from the 6th century BCE on, when, it is commonly held, Carthage attains a special position among the 'Phoenician' settlements in the West. The combined label 'Phoenician/Punic' is used here when such a distinction is not possible. Only for the material culture of Carthage, the label 'Early Punic' is used instead of 'Phoenician', see Maraoui Telmini et al. forthcoming and also below, 'chronology'.
 - 3 See van Dommelen/Gómez Bellard 2010.
 - 4 Vella 2008. A first attempt of discussing the rural landscape of Malta on the basis of published data may be found in Vidal González 2003.
 - 5 Said-Zammit 1997; Sagona 2002.
 - 6 Bonanno 1977; Bruno 2004; Bruno 2009.
 - 7 See also comments in Vella 2010, 462; since the Lisbon conference paper was delivered new evidence for the exploitation, seemingly starting in the 5th century BCE, of a micro-region in Gozo for the production of wine has been put forward (Pace/Azzopardi 2008).
 - 8 Vella 2008, 79-80. In the course of this survey a late 4th/early 3rd century BCE tomb was encountered, excavated and published, Vella et al. 2001.
 - 9 Pedley/Clarke/Galea 2002, 39.
 - 10 The survey seems to have come very timely, since in 2009 and 2010 it could be observed that areas surveyed in the previous year(s) were seriously transformed with the introduction of soil mixed with a fine aggregate of Coralline Limestone to facilitate drainage of soil being prepared for the planting of vines.
 - 11 Hunt/Vella 2008; Vella/Spiteri 2008.
 - 12 Cabreo 1838.
 - 13 Although the theoretical and methodological literature on archaeological surveys is vast, reference should be made to one of the first intensive field surveys in Greece, the Boeotia Survey, for its consequent development of survey theory over the years: Bintliff/Howard/Snodgrass 2007, with full references to earlier literature. For useful summaries see Mattingly 2000 and Banning 2002.
 - 14 Both LV and MDD had been members of the Potenza Valley Survey Project (PVSP). See, for a concise presentation of the survey, Verreyke/Vermeulen 2009, with full references to the preliminary and final survey reports, a.o. in *BABesch* 2001, 2002, and 2005. Apart from 68.5 km² extensively surveyed (a.o. by aerial reconnaissance), the project intensively surveyed 10.72 km² in three sample areas, but only considered the ploughed fields (Verreyke/Vermeulen 2009, 104-105). Line walking took place at 5 to 15 m intervals depending on visibility.
 - 15 A full discussion may be found in De Wulf et al. forthcoming.
 - 16 The fact that especially these garigue plateaux are endangered by urban developments has been highlighted in the press on several occasions; see e.g. E. Deidun, Garigue down the drain, *The Sunday Times* (Malta), September 5, 2010, 59.
 - 17 De Schacht et al. 2008; Stal et al. 2010; Werbrouck et al. 2011.
 - 18 Vassilopoulou et al. 2002.
 - 19 De Wulf et al. 2006.
 - 20 The project is grateful to Charlot Dimech and his colleagues at Datatrak who provided advice about the choice of aerial imagery needed to support our work.
 - 21 Zhang et al. 1996.
 - 22 Luttrell 1975, 13; Dudley Buxton/Hort 1921, 131.
 - 23 Two local fabrics have additionally been distinguished in the frame of the Vienna-based FACEM project, to which the Malta Survey Project has contributed with selected samples, see <http://facem.at/malta-c-1>; <http://facem.at/malta-c-2>.
 - 24 Sagona 2002, 77-84.
 - 25 Sagona 2002, 23-76, with table 1. See the review by Vella 2005 who contests the claims for the early presence of the Phoenicians in Malta and Sagona's response to it (Sagona 2008).
 - 26 Bechtold 2010, esp. 4-5.
 - 27 Zammit 2011.
 - 28 On this, see also Bruno/Cutajar 2002, 109-111.
 - 29 The chronology as given by Sagona (2002, 24, table 1) is rather nebulous in this and the following phase: she gives 410-300 BCE for this sub-phase of III, but also includes the beginning of Phase IV, apparently till the Roman conquest of Malta in 218 BCE. See also Sagona 2008, 528-532.
 - 30 A recent experimental study on visibility factors (Tienhoven 2010) has clearly demonstrated that the common parameters employed in grading the different phases of visibility (vegetation and soil preparation) cannot be considered to be the sole determining factors. Factors such as angle of sunlight, contrast and false targets play an equally important role. Remarkably, statistical analysis showed that ploughed fields appear to be rather unfavourable to visibility, contrary to common opinion.
 - 31 The latter option had already been considered during the campaign, in view of the fact that a vineyard had recently been put in place within this cluster. It could be observed on several occasions that for such agricultural transformations the soil was improved with soil brought in from elsewhere; see also n. 10 above.
 - 32 Tal-Ghazzi consists of the following tract numbers: A106-A136 and A161. Ġebel Ġhawżara is more difficult to define in spatial terms, but the following tracts definitely belong to the site: B21, B16, B55, B83, B99, B74. San Pawl Milqi is pronounced as is, but the letter q in Standard Maltese corresponds to a glottal stop, very much like the glottal stop in the Cockney word bo'el for bottle.

- 33 Cabreo 1838, 36-37.
- 34 Both the villa of San Pawl Milqi with its olive pressing installations and the olive pressing installations of Bidnija (i.e. on our tract B21) occurred already on the distribution map made by Bonanno for the Roman period, Bonanno 1977, 76 (= Vidal González 1996, 185, fig. 9).
- 35 Zammit 1912, n.p. [item 14]; also Ashby 1915, 48.
- 36 See Vella et al. forthcoming, fig. 5.
- 37 Locatelli 2008, fig. 2.
- 38 This had not been noted in the field, probably due to the fact that passes were made up-slope on a long but rather narrow field: each pass, therefore, contained only a small number of finds. Only by comparing the totality of the finds of the whole tract and of all passes, it became clear that the picture differed considerably from the regular background scatter encountered on all tracts in the survey area.
- 39 Cabreo 1838, f. 40.
- 40 *Missione*, 1964-1971.
- 41 Sagona 2002, 653, fig. 333, plan 3.
- 42 Rossignani 1969, 105; Cagiano de Azevedo 1969a, 95, fig. 7 (T5), pl. 27,2.
- 43 Garbini 1968, with pl. 31,2; Cagiano de Azevedo 1969b, 114.
- 44 See especially Locatelli 2008, and the concluding section, below.
- 45 These trials were carried out at the sites of Ġħar ix-Xiħ (Gozo) and at the Żejtun Roman villa (Malta). The results will be published separately.
- 46 The following conventions are used in the catalogue: H = Height, Diam. = Diameter, L = Length, PH = preserved Height, PL = preserved Length, PW = preserved Width, Th = Thickness, W = Width, Colour descriptions follow *Munsell Soil Color Charts* 1990 Revised edition. Measurements are in cm unless otherwise stated. Inventory numbers of the finds consist of the project's code (MSP2008), the designation of the transect number (1), the tract indicator (e.g. B155), the pass, concentration, wall, or block survey number (e.g. P2, C1, W4, BS24, respectively), and an individual number.
- 47 Vella 2009, 95.
- 48 Evans 1953, 59, fig. 2; Evans 1971, fig. 37,8.
- 49 See Trump/Stoddart/Malone 2009, 233.
- 50 Tanasi 2011, 90.
- 51 Koehler 1981, 451; Whitbread 1995, 255-346, esp. 255-257.
- 52 Koehler 1981, 452, esp. pl. 98f of the end of the 6th century BCE. Her list of sites with three or more examples of the 6th century BCE include Athens, Olympia, Corcyra, Selinus, Gela, Syracuse, Leontini, Leuca, Metapontum, Gravisca and Rome.
- 53 Koehler 1981, 452 (Gela); Sourisseau 2006 (Camerina: 209 examples from the beginning of the 6th till the beginning of the 5th century BCE).
- 54 From the University of Hamburg excavations in the settlement, dating between ca 725 and 550 BCE: Docter 2007, 618, 654-655, figs 335-336, 357. That the necropoleis have not yielded any is hardly surprising, given the fact that Greek amphorae are absent from the funerary repertoires of the metropolis altogether.
- 55 Rossignani 1972, 50-51, fig. 9,10-11 (= Vidal González 1996, fig. 56,10-11); also Ciasca 2000, 1288, 1292, fig. 1.
- 56 Ciasca 1999, 76, 86, figs 7-8; Ciasca 2000, 1288, 1292, fig. 1.
- 57 Sagona 2002, 195-200, 661, 663, figs 341,12-14 (but esp. 14), 343,9.
- 58 Briese/Docter 1992, 35, 33, 41; in general on the cultural phenomenon of adaptation of these Greek shapes into the Phoenician/Punic pottery repertoire, see Docter forthcoming.
- 59 Quercia 2004/2005, 340, 342, 344, figs 4-5.
- 60 Peserico 2002, 21-27, fig. 4, pl. 3.
- 61 Rossignani 1972, 54, fig. 11,1-2.
- 62 D'Andria 1973, 37, fig. 14,2-3.
- 63 Quercia 2004/2005, 340, 342, 344, figs 4-5,5 with reference to the occurrence of the type in Phoenician/Punic tombs (Sagona 2002) on p. 342, n. 26.
- 64 Rossignani 1972, 54, fig. 11,5.
- 65 D'Andria 1973, 37, fig. 14,1.
- 66 Quercia 2004/2005, 344, 346, cf. fig. 8,5 (not exact in rim shape and also of later date). See also comments at *Cat.* 8-9.
- 67 Sparkes/Talcott 1970, 134, pl. 33, fig. 9. For their occurrence in Carthage, see Bechtold 2007b, 520, fig. 279.
- 68 Rossignani 1973, 60, fig. 16,4 ('area sud'). She puts these bowls in one group with the larger ones (her fig. 16,2-3), which may have been inspired by other Greek vessel shapes, like for example, the one found in Tas-Silg: D'Andria 1972, 90, cat. D36, fig. 15,16 ('Lamboglia 25', dated to the late 4th and 3rd centuries BCE).
- 69 D'Andria 1972, 89, cat. D34-35, fig. 15,14-15 ('Lamboglia 24A', dated to the 3rd and 2nd centuries BCE).
- 70 Quercia 2004/2005, 343-344, 346, fig. 7,8 (large version) and cf. fig. 8,6 (small version, not exact in rim shape and also of late date).
- 71 Ramón 1995, 197-198, 412-413, 527-531, 625, figs. 63 (esp. fig. 63,1), 164-168, 259, map 63.
- 72 Sagona 2002, 637, 730, fig. 317,4. Malta is missing on Ramón's distribution chart, Ramón 1995, 625, fig. 259, map 63.
- 73 Ramón 1995, 205-206, 425, 535-536, 630, figs 74, 172-173, 264, map 74. Malta is missing on this distribution map.
- 74 Ramón 1995, 209, 429, 538, 632, figs 78, 175, 266, map 78.
- 75 From 'area sud', Rossignani 1972, 58-59, fig. 14,4; also Ramón 1995, 122, 632, fig. 266, map 78.
- 76 Rotroff 1982, esp. 14 (fabric), 6-13, 36 (chronology); in general on relief bowls Docter 2001.
- 77 See e.g. Rotroff 1982, pl. 88,398, imported.
- 78 Bonanno 2005, 168-169, with fig.
- 79 Hayes 1972, 20-25, fig. 2.
- 80 Lund 1995, 476.
- 81 Rossignani 1967, 68-69, figs. 10,3, 10,5.
- 82 Blagg 1990, 58-60, fig. 14,42.
- 83 Sagona 2002, 287-288, 452, fig. 132,12 (horse) and several riders on horseback (Mithras); p. 657, fig. 337,2 (bovine).
- 84 Neeff/Docter 2009, 9-10, fig. 1.
- 85 Rossignani 1973, 59 ('area sud').
- 86 Rossignani 1969, 102-104, pls. 28,1-4, 29,1; Cagiano de Azevedo 1969a, 95, fig. 7 (south of S11), pl. 27,3.
- 87 E.g. Rakob 1991, pl. 69,7. See also Schmidt 1997, generally on the *pavimenta punica*; Schmidt 2007.
- 88 Fantar 1984, 504-505, 537, pls L-LI (*opus tessellatum*).
- 89 Rossignani 1968, 69, pl. 36,5 (*opus signinum*).
- 90 Fantar 1984.
- 91 In Carthage, for example, only 12 tile fragments were encountered in contexts of the Punic period or could be attributed to types of that period, Schwandner 2007, 260-263, cat. 1201-1212, figs 94-100. Apparently, Punic houses seem to have been characterized by flat roofs, with only few and special tile covered areas, like small porticos (Docter/Niemeyer/Schmidt 2007, 190-191, fig. 73, differently Schwandner 2007, 260).

- ⁹² Pedley/Clarke/Galea 2002, 56-57, fig. 69.
- ⁹³ They may have been referred to in Rossignani 1968, 69.
- ⁹⁴ Cintas 1976, 94, pl. LVI,3-4 (Kerkouane); Fantar 1984, 278-282, 387-388, pl. III (Kerkouane); Schmidt 2007, 209-210, fig. 81, pl. 24b, e (Carthage); generally Mezzolani 1999, 159-161, 165, figs 1-2, 4, 6 (Carthage and Kerkouane, mentioning two further examples from Sousse).
- ⁹⁵ Mezzolani 1999, 163-164.
- ⁹⁶ Mezzolani 1999, 163-164, n. 39, 41: Th 3-6 cm vs. 2-3 cm.
- ⁹⁷ Roman Domus: Bonanno 2005, 160 (chronology), 164 with fig. (tile floor). The following quotation is his.
- ⁹⁸ To the best of our knowledge, this floor has not yet been published. It is situated in the south-eastern corner of room F, just to the right, when entering F from door S7, see Cagiano de Azevedo 1969a, fig. 7 (fold-out plan of the site).
- ⁹⁹ Cintas 1976, 94, pl. LVI,1-2 (Carthage, Maison Clariond); Mezzolani 1999, 161-162, 164, figs 3, 5 (Kerkouane). Mezzolani lists many more examples in North African contexts dating till within the Roman period.
- ¹⁰⁰ ARS 104: Hayes 1972, 160-166, fig. 30, esp. fig. 30,15-16 (ARS 104B, dated to 570-600 CE with late versions dating even to 625+ CE); ARS 105: Hayes 1972, 164, 166-169, fig. 31.
- ¹⁰¹ Lund 1995, 533-538.
- ¹⁰² Lund 1995, 538, 611, fig. 16.
- ¹⁰³ Bruno/Cutajar 2002, 128
- ¹⁰⁴ Bruno/Cutajar 2002, 115, 119, 123.
- ¹⁰⁵ Bruno/Cutajar 2002, 119.
- ¹⁰⁶ Ciasca 1967, 35, fig. 6,21-22 ('area 2 sud'); Martinelli Coco 1972, 26, figs. 5,1, 5,4 ('area nord').
- ¹⁰⁷ Robinson 1985, 154.
- ¹⁰⁸ Hayes 1980, 3-10.
- ¹⁰⁹ A. Wetz, manager of Malta Pipeworks at Marsa, who works with briar, kindly informs that neither he nor his father remember reed pipes being made locally. In their opinion they were imported. A resident from Zejtun interviewed in 1992 remembered an old man who made and sold pipes. He also said his grandfather bought red *pipi tal-qasba* from itinerant North Africans who sold them in Malta before 1940 at two and a half pence (less than a cent), along with the sweet sedge root *habb għaziż*, the latter being a treat for the children. According to the late Salvu Āxiaq, a life-long pipe smoker, the Gozitan potter Carmel Sacco dug and processed clay from il-Harrax. Sacco occasionally made pipes for Āxiaq. Tessie Vella, formerly of Rabat, said a professional potter worked at Bir Riebu (a suburb of that town) in the 1930s. He made pipes as a side-line for his friends. She also remembered North African nationals selling attractive pipes in cream coloured clay.
- ¹¹⁰ Cutajar 1987.
- ¹¹¹ See e.g. Wood 2008.
- ¹¹² Wood 2001, 85.
- ¹¹³ Freller 1997, 83.
- ¹¹⁴ Copy of illustration in the National Library (Valletta); present whereabouts unknown.
- ¹¹⁵ Badger 1989, 92.
- ¹¹⁶ Museum of Fine Arts Valletta.
- ¹¹⁷ E.g. from the Quarantine Harbour, Wood 2008, 18-21, figs 4-5 (QH023, QH048, QH055, QH063).
- ¹¹⁸ Only very few fragments from this tract seem to date to Late Antiquity. Study of the later finds by other members of the finds' team has shown that the site was in use well into the Middle Ages.
- ¹¹⁹ MSP08/B16/BS14/6, see Hayes 1972, 41-43, fig. 6; Lund 1995, 483. I owe the identification of this and the following fragment to K. Schmidt (Tübingen).
- ¹²⁰ MSP08/1/B16/BS13/14; see Hayes 1972, 19-43, figs 1-6.
- ¹²¹ Sagona 2002, 24, 665, fig. 345.
- ¹²² Groenewoud/Vidal González 2000, 194-196, figs 4-5.
- ¹²³ Ciasca 1985, 20-22; Ciasca 2000, 1291, 1296, fig. 6. See also Bonanno 2005, 110-113 with figs.
- ¹²⁴ Toepfer 2011, 57, fig. 18: 62.3% (N=122) of the fragments may be attributed to urns of Sagona's type III-IV:4a-b.
- ¹²⁵ Vegas 1999, 179-180, fig. 87a; Bechtold 2007a, 380-382, sub-type A, fig. 193, with further references.
- ¹²⁶ Vandermersch 1994, 69-72.
- ¹²⁷ See now Gassner/Trapichler 2010, 164, fig. 109, phase C3.
- ¹²⁸ Campagna 2000, 446-447, cat. 9-15, fig. 1d: variant 2.3.1.
- ¹²⁹ Anelli 2001, 42, 44, pl. 6,70, dated to the late 4th or early 3rd century BCE.
- ¹³¹ See FACEM: <http://facem.at/pae-a-3>.
- ¹³² For a full discussion of this phenomenon, see Bechtold forthcoming, § 13, B.5, 'impasto 9'.
- ¹³³ Fulford 1994, 64, 66, fig. 4,9.
- ¹³⁴ For a first discussion of the presence of handmade cooking pots within archaeological deposits of Malta see Blagg 1990, 66-69, fig. 17.
- ¹³⁵ Peserico 2002, 29-31, pl. 5.
- ¹³⁶ Ciasca 1999, 77. A slightly earlier beginning - towards the end of the 5th century BCE - of the documentation of this technique has been recently proposed by Quercia (2004-2005, 342).
- ¹³⁷ Rossignani 1967, 64, pl. 51,3. Although not explicitly referred to on p. 64, she lists this type of pottery in the Punic period, but contextually to the 2nd and 1st centuries BCE. Also Rossignani 1968, 64, fig. 7,25, pl. 32,3 (3rd-2nd century BCE).
- ¹³⁸ Ciasca 1985, 20.
- ¹³⁹ Bechtold 2007a, 370, fig. 184 with further references.
- ¹⁴⁰ Liko 2001.
- ¹⁴¹ Vandermersch 1994, 81-87.
- ¹⁴² Sanmarti Grego/Principal Ponce 1998, 195-196, fig. 4.
- ¹⁴³ Sanmarti Grego/Principal Ponce 1998, 196-197, fig. 6,4-5 (Parking Emporion).
- ¹⁴⁴ Lamboglia 1952, 162.
- ¹⁴⁵ D'Andria 1973, 32, 35, figs. 11,4, 12,8.
- ¹⁴⁶ See e.g. Panella 2001, 195; Martin-Kilcher 1993, 278-280; 307-309, figs 22-24; van der Werff 1986, 103-107.
- ¹⁴⁷ Bruno 2004, 142, with references; Bruno 2009.
- ¹⁴⁸ Bruno/Capelli 2000, 59-61, fig. 2.
- ¹⁴⁹ For a recent, exhaustive discussion of this class see Martin-Kilcher 2003, esp. 79, fig. 9,1, from a Gaulish context attributed to the middle of the 1st century BCE. Dressel 9 amphorae are documented for more or less one century and disappear with the late Augustan period (p. 77, fig. 7).
- ¹⁵⁰ van der Werff 1986, 114.
- ¹⁵¹ Martin-Kilcher 1993, 311-312, fig. 26.
- ¹⁵² Bruno 2004, 146; D'Andria 1973, 30, fig. 10,5: a Dressel 8 amphora from a context dated to within the Byzantine period.
- ¹⁵³ D'Andria 1973, 36, fig. 13,1-5, from 'fossa I'; Quercia 2004-2005, 343-344, fig. 5,21; also Bonanno/Frendo/Vella 2000, 91-92, fig. 12,2. Furthermore Sagona 2002, 24, 666, fig. 346,38-39, shapes typical of phase IV (300-100 BCE).
- ¹⁵⁴ For an item from Tas-Silg, 'area nord', 'fossa II', dated to within the last quarter of the 4th century BCE, see D'Andria 1973, 37, fig. 14,2-3.
- ¹⁵⁵ Quercia 2004-2005, 342-344, fig. 5. The best comparison for *Cat.* 52 has been published by Sagona in Bonanno/Frendo/Vella 2000, 91-92, fig. 12,1, n. 64, 'plate with wide floor'.

- ¹⁵⁶ After conclusion of the manuscript for this contribution, it became clear that the best parallels for this rim would rather be found in archaeological contexts of the 1st century BCE to the first half of the 2nd century CE, Rossignani 1967, 69-69, figs 10,3, 10,5.
- ¹⁵⁷ Quercia 2004-2005, 347, n. 34, 348, fig. 10.
- ¹⁵⁸ Ciasca 1967, 29, fig. 4,28.
- ¹⁵⁹ *Conspectus*, 158-159, fig. 6,10.
- ¹⁶⁰ See e.g. van der Werff 1986, 107-108; Martin-Kilcher 1993, 274-277, 299-301, figs 14-17; Panella 2001, 181, 193-194.
- ¹⁶¹ Martin-Kilcher 1998, 512-520, fig. 3; 525, fig. 7a.
- ¹⁶² Bruno 2004, 143; Bruno 2009.
- ¹⁶³ Panella 2001, 209, n. 270.
- ¹⁶⁴ Bonifay 2004, 102-105, fig. 54.
- ¹⁶⁵ Peacock/Bejaoui/Belazreg 1989, 188-189, 210, fig. 11,1.
- ¹⁶⁶ van der Werff 1982, pl. 52,10.
- ¹⁶⁷ For a synthesis and further references see Panella 2001, 195, and esp. 253, fig. 3, 21-22, from Forlimpopoli, for the characteristic depression inside the neck in correspondence with the handle attachment outside.
- ¹⁶⁸ The typological identification of *Cat. 55* and *59* has been kindly made by Schmidt (Tübingen).
- ¹⁶⁹ Sagona 2002, 84.
- ¹⁷⁰ Hayes 1972, 33-35, fig. 4; Lund 1995, 480.
- ¹⁷¹ 1 fragment of Red Slip Ware, 2 fragments of Cooking Ware, and 6 fragments of Plain Ware vessels.
- ¹⁷² Sagona 2002, 666, pl. 346.
- ¹⁷³ Deneauve 1969, 228, pl. V,66, 70; Bechtold 2007c, 597, fig. 319.
- ¹⁷⁴ Blagg 1990, 74-76, fig. 20,191. The fabric description is taken from cat. 176 in Blagg 1990, 76 to which the description of cat. 191 refers.
- ¹⁷⁵ Murray 1929, 21, fig. 33.
- ¹⁷⁶ See Bechtold 2008, 736, cat. 5, pl. CXXVII with further references, especially to the classification of the Bolsena material by Ch. Goudineau, where this shape does not occur before the early 1st century BCE.
- ¹⁷⁷ Locatelli 2008, esp. 1360-1362, 1366-1370 and p. 1353 (date). These calculations are also suggestive of the presence in the area of one or more amphora production sites. These may probably have been situated lower in the valley, where clay, water and combustibles may have been available. On the Maltese production of transport amphorae, Bruno 2004, 85-97; Bruno 2009; see also Locatelli 2008, 1354-1355, with more references in n. 10.
- ¹⁷⁸ Locatelli 2005/2006, 263-264. 'Periodo I' covers all the prehistoric evidence on the site.
- ¹⁷⁹ Locatelli 2005/2006, 264, 266-268, fig. 2. In a more recent article a slightly later date is proposed for this phase, the end of the 1st century CE, Locatelli 2008, 1353.
- ¹⁸⁰ Locatelli 2005/2006, fig. 2.
- ¹⁸¹ Locatelli 2005/2006, 267-268.
- ¹⁸² Fentress/Docter 2008, esp. 120-122, 126-127; Docter 2009, esp. 186-187. One should note, however, that P. van Dommelen and C. Gómez Bellard (2008, 231-240) stress a later moment for the major rural expansion, viz. the 4th century BCE.
- ¹⁸³ See on this already Locatelli 2008, 1364, with n. 42 for the Roman period ('managed settlement pattern'), taking over a term introduced by E. Fentress (2001, 260-266) for the Carthaginian agricultural policy of cash-cropping of wine and oil (also Fentress/Docter 2008, 120-122). One may also mention in this context the Corinthian olive oil amphora *Cat. 6, fig. 20*; also Locatelli 2008, 1365, with n. 47 and reference to Bruno 2004, 61.
- ¹⁸⁴ Locatelli 2005/2006, 257; Gambin 2004, 133-139.

- ¹⁸⁵ The finds from all tracts belonging to the wider Tal-Ghazzi site have been systematically screened and studied by NC, in order to obtain a clear and detailed picture of the Late Antique, Medieval and Early Modern land use. The other tracts in the survey area are currently being processed in the same way.

BIBLIOGRAPHY

- Anelli, M. 2001, La "Fattoria delle api" sull'Irminio. La ceramica di uso comune, *Sicilia Archeologica* 34, fascicolo 99, 33-50.
- Ashby, T. 1915, Roman Malta, *JRS* 5, 23-80.
- Badger, G. 1989, *Description of Malta and Gozo*, Malta.
- Banning, E.B. 2002, *Archaeological Survey* (Manuals in Archaeology Method, Theory, and Techniques), New York.
- Bechtold, B. 2007a, Die phönizisch-punische Gebrauchskeramik der archaischen bis spätpunischen Zeit, in H.G. Niemeyer et al., *Karthago. Die Ergebnisse der Hamburger Grabung unter dem Decumanus Maximus* (Hamburger Forschungen zur Archäologie 2), Mainz a.R., 327-431.
- Bechtold, B. 2007b, Die importierte und lokale Schwarzfirnis-Ware, in H.G. Niemeyer et al., *Karthago. Die Ergebnisse der Hamburger Grabung unter dem Decumanus Maximus* (Hamburger Forschungen zur Archäologie 2), Mainz a.R., 492-587.
- Bechtold, B. 2007c, Lampen, in H.G. Niemeyer et al., *Karthago. Die Ergebnisse der Hamburger Grabung unter dem Decumanus Maximus* (Hamburger Forschungen zur Archäologie 2), Mainz a.R., 596-608.
- Bechtold, B. 2008, Il materiale archeologico datante del SAS 6 (scavi 1990 e 1993), in R. Camerata Scovazzo (ed.), *Segesta III. Il sistema difensivo di Porta di Valle (scavi 1990-1993)*, Mantova, 735-737.
- Bechtold, B. 2010, The Pottery Repertoire from Late 6th – Mid 6th Century BC Carthage, *Carthage Studies* 4, 1-82.
- Bechtold, B. forthcoming, Le anfore da trasporto da Cossyra: un'analisi diacronica (VIII sec. a.C. - VI sec. d.C.) attraverso lo studio del materiale dalla ricognizione, in M. Almonte (ed.), *Cossyra. Ricognizione topografica. Storia di un paesaggio mediterraneo* (Tübinger Forschungen zur Archäologie. Cossyra 2).
- Bintliff J./P. Howard/A. Snodgrass 2007, *Testing the hinterland. The work of the Boeotia Survey (1989-1991) in the southern approaches to the city of Thespiiai*, Cambridge.
- Blagg, T.F.C. 1990, The Pottery, in T.F.C. Blagg/A. Bonanno/A.T. Luttrell, *Excavations at Hal Millieri, Malta*, Msida, 51-80.
- Bonanno, A. 1977, Distribution of villas and some aspects of the Maltese economy in the Roman period, *Journal of the Faculty of Arts (Malta)* 6,4, 73-81.
- Bonanno, A. 2005, *Malta. Phoenician, Punic, and Roman*, Valletta.
- Bonanno, A./A.J. Frendo/N.C. Vella 2000, Excavations at Tas-Silg, Malta. A Preliminary Report on the 1996-1998 Campaigns Conducted by the Department of Classics and Archaeology of the University of Malta, *MedA* 13, 67-114.
- Bonifay, M., 2004, *Études sur la céramique romaine tardive d'Afrique* (BAR International Series 1301), Oxford.
- Briese, Ch./R.F. Docter 1992, Der phönizische Skyphos. Adaption einer griechischen Trinkschale, *MM* 33, 25-69.
- Bruno, B. 2004, *L'arcipelago maltese in età romana e bizantina. Attività economica e scambi al centro del Mediterraneo*, Bari.
- Bruno, B. 2009, *Roman and Byzantine Malta: Trade and Economy* (Maltese Social Studies 15), Malta.
- Bruno, B./C. Capelli 2000, Nuovi tipi di anfore da tra-

- sporto a Malta, in C. d'Amico/C. Tampellini (eds), *Atti della 6ª giornata: le scienze della terra e l'archeometria (Este 1999)*, Este, 59-65.
- Bruno, B./N. Cutajar 2002, Archeologia bizantina a Malta: primi risultati e prospettive di indagine, *VO Quad* 3,1, 109-138.
- Buhagiar, M. 1986, *Late Roman and Byzantine Catacombs and Related Burial Places in the Maltese Islands* (BAR. International Series 302), Oxford.
- Cabreo, 1838, *Descrizione generale di tutt'i beni stabili esistenti nella isola di Malta e Gozo spettanti alla S. Chiesa Catted. Arcivesc. di Malta colle loro denominazioni, piante, capacità, contrade, confini, concessioni, ed annuo canone e di alcuni ricognizioni terminata correndo l'anno 1838* (Manuscript held at the Cathedral Archives, Mdina, Malta).
- Cagiano de Azevedo, M. 1969a, S. Paolo Milqi. Lo Scavo, in *Missione Archeologica Italiana a Malta. Rapporto preliminare della Campagna 1968*, Rome, 93-95.
- Cagiano de Azevedo, M. 1969b, Gli scavi della campagna 1968, in *Missione Archeologica Italiana a Malta. Rapporto preliminare della Campagna 1968*, Rome, 109-115.
- Campagna, L. 2000, Le anfore della necropoli in Contrada Portinenti (Proprietà Leone), in L. Bernabò Brea/M. Cavalier (eds), *Scoperte e scavi archeologici nell'area urbana e suburbana di Lipari (Meligunìs Lipàra X)*, Palermo, 443-478.
- Ciantar, G.A. 1772, *Malta Illustrata ovvero Descrizione di Malta* (revised edition of G.F. Abela, *Della descrizione di Malta Isola nel Mare Siciliano*, 1647), Malta.
- Ciasca, A. 1967, Tas – Silg. Lo scavo, in *Missione Archeologica Italiana a Malta. Rapporto preliminare della Campagna 1966*, Rome, 25-36.
- Ciasca, A. 1985, Note sulla distribuzione di alcune ceramiche puniche maltesi, *Bulletin archéologique du Comité des Travaux Historiques et Scientifiques, nouvelle série* 19, année 1983, fascicule B, *Afrique du Nord*, Paris, 17-24.
- Ciasca, A. 1999, Sicilia e Malta. Note su repertori ceramici a confronto, in A. González Prats (ed.), *La cerámica fenicia en Occidente: centros de producción y áreas de comercio*, Alicante 21-24 de noviembre 1997. *Actas del I Seminario Internacional sobre Tepas Fenicias, Guardamar del Segura*, 21-24 de noviembre de 1997, Alicante, 69-87.
- Ciasca, A. 2000, Imitazioni di forme esterne nella ceramica di Malta, in M.E. Aubet/M. Barthélemy (eds), *Actas del IV Congreso Internacional de Estudios Fenicios y Punicos*, Cádiz, 2 al 6 de Octubre de 1995, Cádiz, 1287-1296.
- Cintas, P. 1976, *Manuel d'Archéologie Punique II. La civilisation carthaginoise. Les réalisations matérielles*, Paris.
- Conspectus (Consp.)* = Ettlinger, E. et al. 2002, *Conspectus formarum terrae sigillatae Italico modo confectae* (Materialien zur Römisch-Germanischen Keramik 10), Bonn (second edition).
- Corretti, A./C. Capelli 2003, Entella. Il granaio ellenistico (SAS 3). Le anfore, in *Quarte Giornate Internazionali di Studi sull'Area Elima (Erice 2000)*, Pisa, 287-351.
- Cutajar, D. 1987, *The Malta Quarantine Shipping and Trade 1654-1697*, Mid Med Bank, Malta.
- D'Andria, F. 1972, Catalogo della ceramica greca italiota e a vernice nera, in *Missione Archeologica Italiana a Malta. Rapporto preliminare della Campagna 1969*, Rome, 77-95.
- D'Andria, F. 1973, Saggio stratigrafico nell'area Nord, in *Missione Archeologica Italiana a Malta. Rapporto preliminare della Campagna 1970*, Rome, 29-41.
- Deneauve, J. 1969, *Lampes de Carthage*, Paris [1974 edition].
- De Schacht, T./W. Gheyle/R. Goossens/A. De Wulf 2008, Archaeological Research and CORONA: On the Use, Misuse and Full Potential of Historical Remote Sensing Data, in *Proceedings of the 5th International Congress on the Archaeology of the Ancient Near East*, Madrid, 611-618.
- De Wulf, A./M. Brondeel/T. Willems/T. Neutens 2006, GPS Work of Ghent University, *Bulletin de la Société Géographique de Liège* 47, 57-72.
- De Wulf, A./R.F. Docter/C. Stal/R. Goossens/T. Nuttens/N. Vella (forthcoming), Integrated 3D Geomatics for Archaeology: Case Study Malta, in L. Halounová (ed.), *Remote Sensing and Geoinformation: not only for Scientific Cooperation. Proceedings of the EARSeL Symposium*.
- Docter, R.F. 2001, Reliefkeramik, in H. Cancik/H. Schneider (eds), *Der Neue Pauly. Enzyklopädie der Antike* 10, Stuttgart/Weimar, 885-886.
- Docter, R.F. 2007, Archaische Transportamphoren, in H.G. Niemeyer et al., *Karthago. Die Ergebnisse der Hamburger Grabung unter dem Decumanus Maximus* (Hamburger Forschungen zur Archäologie 2), Mainz a.R., 616-662.
- Docter, R.F. 2009, Carthage and its hinterland, in S. Helas/D. Marzoli (eds), *Phönizisches und punisches Städtewesen* (Iberia Archaeologica 13), Mainz a.R., 179-189.
- Docter, R.F. (forthcoming), The Phoenician Practice of Adapting Greek Drinking Vessels (Skyphoi and Kotylai), in R. Graells et al. (eds), *El problema de las "imitaciones" durante la protohistoria en el Mediterráneo centro-occidental: entre el concepto y el ejemplo* (Iberia Archaeologica), Mainz a.R.
- Docter, R.F./H.G. Niemeyer/K. Schmidt 2007, Die punischen Häuser. Bautypologie und Raumfunktion, in H.G. Niemeyer et al., *Karthago. Die Ergebnisse der Hamburger Grabung unter dem Decumanus Maximus* (Hamburger Forschungen zur Archäologie 2), Mainz a.R., 175-199.
- Dudley Buxton, L.H./A.V.D. Hort 1921, The modern pottery industry in Malta, *Man* 21, 130-131.
- Evans, J.D. 1953, The prehistoric culture sequence of the Maltese archipelago, *Proceedings of the Prehistoric Society* 19, 41-94.
- Evans, J.D. 1971, *The Prehistoric Antiquities of the Maltese Islands. A Survey*, London.
- Fantar, M. 1984, *Kerkouane. Cité Punique du Cap Bon (Tunisie) I*, Tunis.
- Fentress, E. 2001, Villas, Wine and Kilns: The Landscape of Jerba in the Late Hellenistic Period, *JRA* 14, 249-268.
- Fentress, E./R.F. Docter 2008, North Africa: Rural Settlement and Agricultural Production, in P. van Dommelen/C. Gómez Bellard (eds), *Rural Landscapes of the Punic World* (Monographs in Mediterranean Archaeology), London/Oakville, 101-128.
- Freller, T. 1997, *Gozo: The Island of Joy*, Malta.
- Fulford, M. 1994, The Cooking and Domestic Wares, in M.G. Fulford/D.P.S. Peacock, *The Circular Harbour, North Side. The Pottery. Excavations at Carthage. The British Mission II,2*, Oxford, 53-75.
- Gambin, T. 2004, Islands of the Middle Sea: an archaeology of a coastline, in L. De Maria/R. Turchetti (eds), *Evolución paleoambiental de los puertos y fundaderos antiguos en el Mediterráneo occidental* (I seminario: El patrimonio arqueológico submarino y los puertos antiguos, Alicante 14-15 noviembre 2003), Rome, 127-146.
- Garbini, G. 1968, L'iscrizione punica, in *Missione Archeologica Italiana a Malta. Rapporto preliminare della Campagna 1967*, Rome, 83-84.
- Gassner, V./M. Trapichler 2010, La ceramica di Velia nel IV e III sec. a.C., in *Ramses Naples. Grecs et indigènes de la Catalogne à la Mer Noire* (Bibliothèque d'Archéologie Méditerranéenne et Africaines 3), Paris, 159-166.
- Groenewould, E./P. Vidal González 2000, Punic Pottery in Malta. Typical Maltese?, in P. Bartoloni/L. Campanella

- (eds), *La Ceramica Fenicia di Sardegna: Dati, Problematiche, Confronti. Atti del Primo Congresso Internazionale Sulcitano, Sant'Antioco, 19-21 Settembre 1997*, Rome, 193-199.
- Hayes, J.W. 1972, *Late Roman Pottery*, London.
- Hayes, J.W. 1980, Turkish Clay Pipes: A Provisional Typology, in P. Davey (ed.), *The Archaeology of the Clay Tobacco Pipe* (BAR International Series 92), Oxford, 3-10.
- Hunt, C./N.C. Vella 2008, A View from the Countryside: Pollen from a Field at Mistra Valley, Malta, *Malta Archaeological Review* 7 [2004/2005], 61-69.
- Koehler, C.G. 1981, Corinthian Developments in the Study of Trade in the Fifth Century, *Hesperia* 50, 449-458.
- Lamboglia, N. 1952, La nave romana di Albegna, *Rivista di Studi Liguri* 18, 131-162.
- Liko, H. 2001, Tafelwein aus der Umgebung - Qualitätswein aus Griechenland. Herkunftsbestimmung großgriechischer Amphoren aus Velia mittels archäometrischer Analyse, *Forum Archaeologiae* 18/III (<http://farch.net>).
- Locatelli, D. 2005/2006, Nuove ricerche a San Pawl Milqi: primi risultati, in M.P. Rossignani, La ripresa delle indagini della Missione Archeologica Italiana a Malta. Nuovi dati dal santuario di Tas-Silg e dalla villa di San Pawl Milqi, *RendPontAc* 78, 257-273.
- Locatelli, D. 2008, L'oro verde di Malta. Stime sulla produzione olearia nella villa San Pawl Milqi: J. González/P. Ruggieri/C. Vismara/R. Zucca (eds), *L'Africa romana XVII: Le ricchezze dell'Africa. Risorse, produzioni, scambi* (Seville, 2006), Rome, 1351-1374.
- Lund, J. 1995, Hellenistic IIIA. Roman and Late Fine Wares from the Segermes Valley - Forms and Chronology, in *Africa Proconsularis II. Regional Studies in the Segermes Valley of North Tunisia. Pottery, Numismatics and the Antiquarian Data*, Copenhagen, 449-629.
- Luttrell, A. 1975, Approaches to Medieval Malta, in A. Luttrell (ed.), *Medieval Malta: Studies on Malta before the Knights*, London, 1-70.
- Maraoui Telmini, B. et. al, forthcoming, Defining Punic Carthage, in J. Quinn/N.C. Vella (eds), *Identifying the Punic Mediterranean*, London.
- Martin-Kilcher, S. 1993, Amphoren der späten Republik und der frühen Kaiserzeit in Karthago. Zu den Lebensmittelimporten der Colonia Iulia Concordia, *RM* 100, 269-320.
- Martin-Kilcher, S. 1998, Le vin dans la Colonia Iulia Karthago, in M. Comas/P. Padros (eds), *El vi a l'Antiguitat. Economia, producció i comerç al Mediterrani Occidental. II colloqui internacional d'arqueologia romana* (Badalona, 6-9 maig de 1998) (Monografies Badalonines 14), Badalona, 511-529.
- Martin-Kilcher, S. 2003, Fish-sauce amphorae from the Iberian peninsula: The forms and observations on trade with the north-west provinces, *Journal of Roman Pottery Studies* 10, 69-84.
- Martinelli Coco, T. 1972, Ceramica romana e bizantina dell'area nord, in *Missione Archeologica Italiana a Malta. Rapporto preliminare della Campagna 1969*, Rome, 25-30.
- Mattingly, D. 2000, Methods of collection, recording and quantification, in R. Francovich/H. Patterson (eds), *Extracting Meaning from Ploughsoil Assemblages* (The Archaeology of Mediterranean Landscapes 5), Oxford, 5-15.
- Mayr, A. 1905, *Aus den Phönikischen Nekropolen von Malta*, Munich.
- Mezzolani, A. 1999, Carrelages en briques cuites dans l'architecture punique, *REPPAL* 11, 157-168.
- Missione 1964-1971, Missione Archeologica Italiana a Malta. Rapporto Preliminare della campagna 1963-1970*, Rome.
- Murray, M. 1929, *Excavations in Malta, Part III*, London.
- Museums Department, 1905, *Museum Annual Report 1905*, Valletta.
- Museums Department, 1908-1920, *Museum Annual Reports 1907-1919*, Valletta.
- Museums Department, 1923-1940, *Museum Annual Reports 1922-1939*, Valletta.
- Museums Department, 1953-1966, *Museum Annual Reports 1952-1965*, Valletta.
- Museums Department, 1973-1974, *Museum Annual Reports 1972-1973*, Valletta.
- Museums Department, 1977-1978, *Museum Annual Reports 1976-1977*, Valletta.
- Museums Department, 1984-1986, *Museum Annual Reports 1983-1986*, Valletta.
- Neeft, K./R. Docter 2009, Een dikke petaike en een slanke aryballos uit Malta, *Mededelingenblad Allard Pierson Museum Amsterdam* 98/99, 9-13.
- Pace, A./G. Azzopardi 2008, Economic landscapes of the Maltese Islands during antiquity: a survey of ancient wine presses (Poster presented at the XVII Congresso Internazionale di Archeologia Classica), Rome.
- Panella, C. 2001, Le anfore di età imperiale del Mediterraneo occidentale, in P. Lèveque/J.-P. Morel (eds), *Céramiques hellénistiques et romaines* (Annales Littéraires de l'Université de Besançon II), Paris, 177-275.
- Peacock, D.P.S./F. Bejaoui/N. Belazreg 1989, Roman Amphora Production in the Sahel Region of Tunisia, in: *Amphores romaines et histoire économique: dix ans de recherche* (Siena 1986), Rome, 180-222.
- Pedley, M./M.H. Clarke/P. Galea 2002, *Limestone Isles in a Crystal Sea. The Geology of the Maltese Islands*, San Gwann.
- Peserico, A. 2002, *Die offenen Formen der Red Slip Ware aus Karthago. Untersuchungen zur phönizischen Keramik im westlichen Mittelmeerraum* (Hamburger Werkstattreihe zur Archäologie 5), Münster/Hamburg/London.
- Quercia, A. 2004/2005, La ceramic punico-maltese del santuario di Tas Silg: Analisi tipológica e funzionale, in *Un luogo di culto al centro del Mediterraneo: il santuario di Tas Silg dalla Preistoria all'età Bizantina. Atti del seminario di studi* (Roma 2005) (Scienze dell'Antichità 12), Rome, 335-354.
- Rakob, F. 1991, Pavimenta punica und Ausstattungselemente der punischen und römischen Häuser, in F. Rakob (ed.), *Die deutschen Ausgrabungen in Karthago* (Karthago I), Mainz a.R., 220-225.
- Ramón Torres, J. 1995, *Las ánforas fenicio-púnicas del Mediterráneo central y occidental* (Col·lecció Instrumenta 2), Barcelona.
- Robinson, R.C.W. 1985, Tobacco Pipes of Corinth and of the Athenian Agora, *Hesperia* 54, 149-203.
- Rossignani, M.P. 1967, Ceramica e trovamenti vari, in *Missione Archeologica Italiana a Malta. Rapporto preliminare della Campagna 1966*, Rome, 63-76.
- Rossignani, M.P. 1968, Ceramica e trovamenti vari, in *Missione Archeologica Italiana a Malta. Rapporto preliminare della Campagna 1967*, Rome, 57-73.
- Rossignani, M.P. 1969, Ceramica e trovamenti vari, in *Missione Archeologica Italiana a Malta. Rapporto preliminare della Campagna 1968*, Rome, 97-105.
- Rossignani, M.P. 1972, Ceramica e trovamenti vari, in *Missione Archeologica Italiana a Malta. Rapporto preliminare della Campagna 1969*, Rome, 47-70.
- Rossignani, M.P. 1973, Ceramica e trovamenti vari, in *Missione Archeologica Italiana a Malta. Rapporto preliminare della Campagna 1970*, Rome, 59-72.
- Rotroff, S.I., 1982, *Hellenistic Pottery. Athenian and Imported Moldmade Bowls* (The Athenian Agora. Results of Excavations of the American School of Classical Studies

- at Athens 22), Princeton, NJ.
- Sagona, C. 2002, *The Archaeology of Punic Malta* (Ancient Near Eastern Studies Supplement 9), Leuven.
- Sagona, C. 2008, Malta: between a rock and a hard place, in C. Sagona (ed.) *Beyond the Homeland: Markers in Phoenician Chronology* (Ancient Near Eastern Studies Supplement 28), Leuven, 487-536.
- Said-Zammit, G. 1997, *Population, Land Use and Settlement on Punic Malta: A Contextual Analysis of the Burial Evidence* (BAR International Series 682), Oxford.
- Sanmartí Grego, E./J. Principal Ponce, 1998, Cronología y evolución tipológica de la Campaniense A del siglo II aC: las evidencias de los pecios y de algunos yacimientos históricamente fechados, in J. Ramón Torres/J. Sanmartí Grego/D. Asensio Vilaró, J. Principal Ponce (eds), *Les facies ceràmiques d'importació a la Costa Ibèrica, les Balears i les Pitiüses durant el segle III aC i la primera meitat del segle II aC* (Arqueomediterrània 4), Barcelona, 193-215.
- Schmidt, K. 1997, *Punische Pavimente in Karthago. Entstehung und Entwicklung*, Hamburg.
- Schmidt, K. 2007, Zur baulichen Ausstattung der Häuser, in H.G. Niemeyer et al., *Karthago. Die Ergebnisse der Hamburger Grabung unter dem Decumanus Maximus* (Hamburger Forschungen zur Archäologie 2), Mainz a.R., 199-213.
- Schwandner, E.L. 2007, Dachziegel, in H.G. Niemeyer et al., *Karthago. Die Ergebnisse der Hamburger Grabung unter dem Decumanus Maximus* (Hamburger Forschungen zur Archäologie 2), Mainz a.R., 260-267.
- Sourisseau, J.-C. 2006, Les amphores commerciales de la nécropole de Rifriscolaro à Camerine. Remarques préliminaires sur les productions corinthiennes de type A, in *Camarina 2600 anni dopo la fondazione. Nuovi studi sulla città e sul territorio. Atti del Convegno Internazionale – Ragusa, 7 dicembre 2002/7-9 aprile 2003*, Rome, 129-147.
- Sparkes, B.A./L. Talcott 1970, *Black and Plain Pottery of the 6th, 5th and 4th Centuries B.C.* (The Athenian Agora. Results of Excavations conducted by the American School of Classical Studies at Athens 12), Princeton, NJ.
- Stal, C. et al. 2010, Kimmelberg (Belgium) Case Study: Comparison of DTM Analysis Methods for the Detection of Relics from the First World War, in *Remote sensing for science, education, and natural and cultural heritage: proceedings of the EARSeL Symposium*, Paris, 65-72.
- Swann, J.S. 1866, Descriptions of Ancient Rock-Tombs at Ghain Tiffiha and Tal Horr, Malta, *Archaeologia* 40,2, London, 483-467.
- Tanasi, D. 2011 The prehistoric pottery, in D. Tanasi/N.C. Vella (eds), *Site, Artefacts, Landscape: Prehistoric Borġ in Nadur, Malta*, Monza, 71-158.
- Tienhoven, D.H. 2010, Op weg naar een meer volledige benadering van zichtbaarheidsproblematiek in archeologische surveys, *TMA Tijdschrift voor Mediterrane Archeologie* 43, 32-37.
- Toepfer, H. 2011, *Maltesische Keramik. Das Fundspektrum und dessen Analyse* (Magisterarbeit Eberhard-Karls Universität Tübingen), Tübingen.
- Trump, D.H. et al. (eds), *The Pottery*, in C. Malone et al. (eds), *Mortuary customs in prehistoric Malta: Excavations at the Brochtorff Circle at Xagħra (1987-94)* (McDonald Institute Monographs), Cambridge, 220-242.
- Van der Werff, J. 1982, *Uzita: vondstenmateriaal uit een antieke nederzetting in midden Tunesie - Uzita. Matériel de fouilles d'une cité antique en Tunisie Centrale*, Utrecht.
- Van der Werff, J. 1986, The amphora Wall in the House of the Porch, Ostia, in J. Boersma/D. Yntema/J. van der Werff, *Excavations in the House of the Porch at Ostia*, *BABesch* 61, 77-137, 96-137.
- Van Dommelen, P./C. Gómez Bellard 2010, *Rural Landscapes of the Punic World* (Monographs in Mediterranean Archaeology 11), London.
- Vandermersch, Ch. 1994, *Vin et amphores de Grande Grèce et de Sicile. IVe-IIIe s. avant J.-C.* (Centre Jean Bérard Études I), Naples.
- Vassilopoulou, S./L. Hurni/V. Dietrich/E. Baltsavias/M. Pateraki/E. Lagios/I. Parcharidis 2002, Orthophoto Generation Using IKONOS Imagery and High Resolution DEM: a Case Study on Volcanic Hazard Monitoring of Nisyros Island (Greece), *ISPRS Journal of Photogrammetry & Remote Sensing*, 56,3, 24-38.
- Vella, C. 2009, The lithic toolkit of the Late Neolithic Ta' Hagra, Malta, *Origini* 31,4, 85-102.
- Vella, N.C. 2005, Phoenician and Punic Malta (review article): *JRA* 18, 436-450.
- Vella, N.C. 2008, Unravelling past agricultural landscapes in the Maltese Islands: making a case for the Phoenician and Punic periods, in A.M. Arruda/C. Gómez Bellard/P. van Dommelen (eds), *Sítios e Paisagens Rurais do Mediterrâneo Púnico. 6º Congresso Internacional de Estudos Fenícios e Púnicos* (Cadernos da Uniarq 3), Lisbon, 69-86.
- Vella, N.C. 2010, Views from the Punic countryside (review article), *JRA* 23, 459-463.
- Vella, N.C./M. Spiteri 2008, Documentary Sources for a Study of the Maltese Landscape, *Storja – Journal of the Malta University Historical Society* 30, 16-29.
- Vella, N.C. et al. (forthcoming), Life and Death in Rural Malta: First results of the joint Belgo-Maltese Survey Project (2008-2009), in A. Ferjaoui (ed.), *Actes du VIIème Congrès International des Études Phéniciennes et Puniqes – Hammamet 2009*, Tunis.
- Verreyke, H./F. Vermeulen 2009, Tracing Late Roman Rural Occupation in Adriatic Central Italy, *AJA* 113, 103-120.
- Vidal González, P. 1996, *La Isla de Malta en Época Fenicia y Púnica* (BAR International Series 653), Oxford.
- Vidal González, P. 2003, Ecología y paisaje fenicio-púnico de la Isla de Malta, in C. Gómez Bellard (ed.), *Ecología del paisaje agrario. La agricultura fenicio-púnica en el Mediterráneo*, València, 255-270.
- Werbrouck, I. et al. 2011, Digital Elevation Model Generation for Historical Landscape Analysis Based on LiDAR Data, a Case Study in Flanders (Belgium), *Expert Systems with Applications* 38,7, 8178-8185.
- Whitbread, I.K. 1995, *Greek Transport Amphorae. A Petrological and Archaeological Study* (Fitch Laboratory Occasional Paper 4), Athens.
- Wood, J. 2001, Tobacco Pipes from Manoel Island, Malta, *Mariner's Mirror* 87,1, 83-88.
- Wood, J. 2008, Tobacco pipes from an underwater excavation at the quarantine harbour, Malta, *Malta Archaeological Review* 7 [2004/2005], 15-26.
- Wood, J. 2009, Malta, *Journal of the Academie International de la Pipe* 2, 87-92.
- Zammit, A. 2011, *Survival of Punic culture during the Roman period: Malta and other central Mediterranean islands*. Unpublished MA dissertation, University of Malta.
- Zammit, T. 1905-1907, *Archaeological Field Notes, Book I*, Manuscript at National Museum of Archaeology Library, Valletta.
- Zammit, T. 1909-1912, *Archaeological Field Notes, Book III*, Manuscript at National Museum of Archaeology Library, Valletta.
- Zammit, T. 1912, *Annual Report of the Curator of the Museum for the Financial Year 1911-1912*, Malta.
- Zammit, T. 1912-1917, *Archaeological Field Notes, Book IV*,

Manuscript at National Museum of Archaeology Library,
Valletta.
Zammit, T. 1916-1921, *Archaeological Field Notes, Book V*,
Manuscript at National Museum of Archaeology
Library, Valletta.
Zammit, T. 1922-1924, *Archaeological Field Notes, Book VII*,
Manuscript at National Museum of Archaeology Library,
Valletta.
Zammit, T. 1924-1925, *Archaeological Field Notes, Book VIII*,
Manuscript at National Museum of Archaeology
Library, Valletta.
Zhang, J. et al. 1996, *VirtuoZo Digital Photogrammetry
System: its Theoretical Foundation and Key Algorithms*,
*International Archives of Photogrammetry and Remote
Sensing* 31,B2, 424-429.

ROALD F. DOCTER
DEPARTMENT OF ARCHAEOLOGY
GHENT UNIVERSITY
SINT-PIETERSNIEUWSTRAAT 35
B-9000 GENT
roald.docter@ugent.be

ANTHONY BONANNO
NICHOLAS C. VELLA
DEPARTMENT OF CLASSICS AND ARCHAEOLOGY
UNIVERSITY OF MALTA
MSIDA MSD 2080
MALTA
anthony.bonanno@um.edu.mt
nicholas.vella@um.edu.mt

NATHANIEL CUTAJAR
ANTHONY PACE
SUPERINTENDENCE OF CULTURAL HERITAGE
173, ST. CHRISTOPHER STREET
VALLETTA VLT 2000
MALTA
nathaniel.cutajar@gov.mt
anthony.pace@gov.mt