

TREATED SEWAGE EFFLUENT – AN ALTERNATIVE WATER SUPPLY FOR THE MALTESE ISLANDS

J. Mangion*; P. Micallef and G. Attard*****

* Malta Resources Authority; Millenia Aldo Moro Rd – Marsa

E-mail: jmangion@mra.org.mt

** Water Service Corporation, E-mail: paul.micallef@wsc.com.mt

*** Institute of Agriculture University of Malta, MSIDA MSD, 06 Malta

E-mail: gorge.attard@um.edu.mt

1. GENERAL

Water is a scarce substance in the Maltese islands because of geographic and climatic conditions. Malta has no surface waters that can be economically exploited; the islands depend on frail groundwater resources that are subject to fierce competition and constant pressure resulting from intense human activity over a relatively small territory. As a result, the status of groundwater in Malta is today under constant threat of anthropogenic activity that is reflected through quality and quantity depletion of the resource. Malta is among the first 10 top-ranking countries in global water scarcity with the highest competition index (Table 1) of 24,800 inh/hm³.yr in 1995 (Margat and Vallee, 2000).

Table1. Comparison of water resource indicators of Malta with other national Mediterranean basins

Country	Reference period	Population (1,000)	Surface area of country's Mediterranean basin (km ²)	Water resources (m ³ /yr.cap)	Competition index (inh./hm ³ .yr)
Malta	1995	372	316	40	24,800
Gaza Strip	1995	843	365	66	15,054
Israel	1994	5,472	10,500	178	5,612
Libya	1994	3,246	158,864	216	4,637
West Bank	1995	1,407	2,420	277	3,608
Tunisia	1994	8,033	90,000	437	2,289
Morocco	1990	4,426	80,000	859	1,165
Cyprus	1995	734	9,251	1,076	929
Algeria	1987	10,791	133,000	1,087	920
Egypt	1995	46,545	200,000	1,210	827
Syria	1994	4,530	22,000	1,269	788
Lebanon	1992	3,000	9,800	1,546	647
Spain	1991	16,360	185,600	1,733	577
Italy	1990	57,104	301,277	2,934	341
Turkey	1995	17,180	195,000	3,565	280
France	1990	11,937	130,100	5,906	169
FYR of Macedonia	1991	2,100	25,700	5,952	168
Yugoslavia	1991	1,246	6,322	6,301	159
Greece	1991	10,264	131,944	6,450	155
Albania	1990	3,256	28,748	13,080	76
Croatia	1991	1,403	37,205	18,598	54
Slovenia	1992	227	4,835	23,927	42
Bosnia Herzegovina	1991	545	16,301	25,039	40

Source: Margat and Vallee, 2000

Notes: 1. Data refers to Mediterranean basin only of the country
2. Countries sorted in ascending order of water resources per capita.

Non-conventional sources of water supply offer an attractive alternative to meet water demand and complement groundwater. This paper seeks to identify the availability of treated sewage effluent (TSE) during the next years and highlights the future possibilities of re-using treated sewage effluent

(TSE) in Malta and Gozo for agriculture, a sector that is a major consumer of fresh water as in other countries.

2. DEMOGRAPHY

The Maltese Archipelago consists mainly of three inhabited islands, Malta, Gozo, and Comino having a total surface area 315.59 km². Figures published by the National Statistics Office report a population figure amounting to 388,867 in 2003 and showing an average growth rate of less than 1000/yr.

Population density in the Maltese islands is amongst the highest in the world, reaching 1250 inh/km² distributed rather unevenly over the territory. One of the inner harbour localities has the highest concentration with 22,074 inh/km² (Mallia *et al.*, 2002).

When the million tourists, visiting Malta annually, are taken into account the aggregated population figure summed up to 427,000 in 2003. Projections show steady growth of the local population up to 2025 and a gradual decline reaching 360,000 by 2060. These figures are only meant to provide a perspective of the pressure for water resources in a Mediterranean island scenario.

3. TREATED SEWAGE EFFLUENT FLOW BALANCE

There is not sufficient data backed by direct measurements to arrive at the total volume of sewage available. Hence an estimate has been made by deriving a flow-balance model (Cassar1998) to determine the total availability of treated sewage effluent, departing from the official figure of 37.88 Mm³ for water production in 2001/2002. Key assumptions made for the computation of the flow balance are shown below (Table2).

Table 2. Flow-balance parameters for TSE availability projections (all figures in Mm³)

Desalinated water supply	19.87	Measured
Groundwater supply	18.01	Measured of which only 14mm3 supplied after treatment
Reservoir losses	-0.4	Estimated at 2% of flow through reservoir
Distribution network losses	-9.2	Estimated figure based on projections for leakage reduction
Input from private RO including other supply	1.3	Includes use by industry of TSE from San Antnin TP and estimated 3% contribution of sewage from private RO plants
Non return use	-3.6	Estimated at 15% of WSC demand. This is due to gardening and other uses where tap water is not returned to the sewer. Estimate based on results of pilot area that showed 81/82% of inflow returned to sewage
Drainage system losses	-3.3	Assumed at 15% of the sewage flowing through 2000km network having a leakage rate of 20l/hr/100m
Drainage system infiltration	1.4	15% of the leakages from the potable water network that find their way into the sewerage network
Available for treatment	18.71	At plant inlet
Treatment plant reject	-1.9	Estimated 10% of the in flow
Distribution system losses	-2.5	Estimated at 15% of flow in the system
Available TSE	14.3	Balancing figure

On the basis of this model, 14.3 Mm³/year of treated sewage effluent are expected to be available for re-use in Malta and Gozo (Fig. 1). As a signatory to the Barcelona Convention, Malta is committed to treat all wastewater before dumping at sea and is thus planning to set up three new sewage treatment plants: one in Gozo, and two in Malta. The plant in Gozo and that in the north of Malta are expected to become operational by 2006 while the largest of these plants, that for the south of Malta, is planned to be completed by 2007.

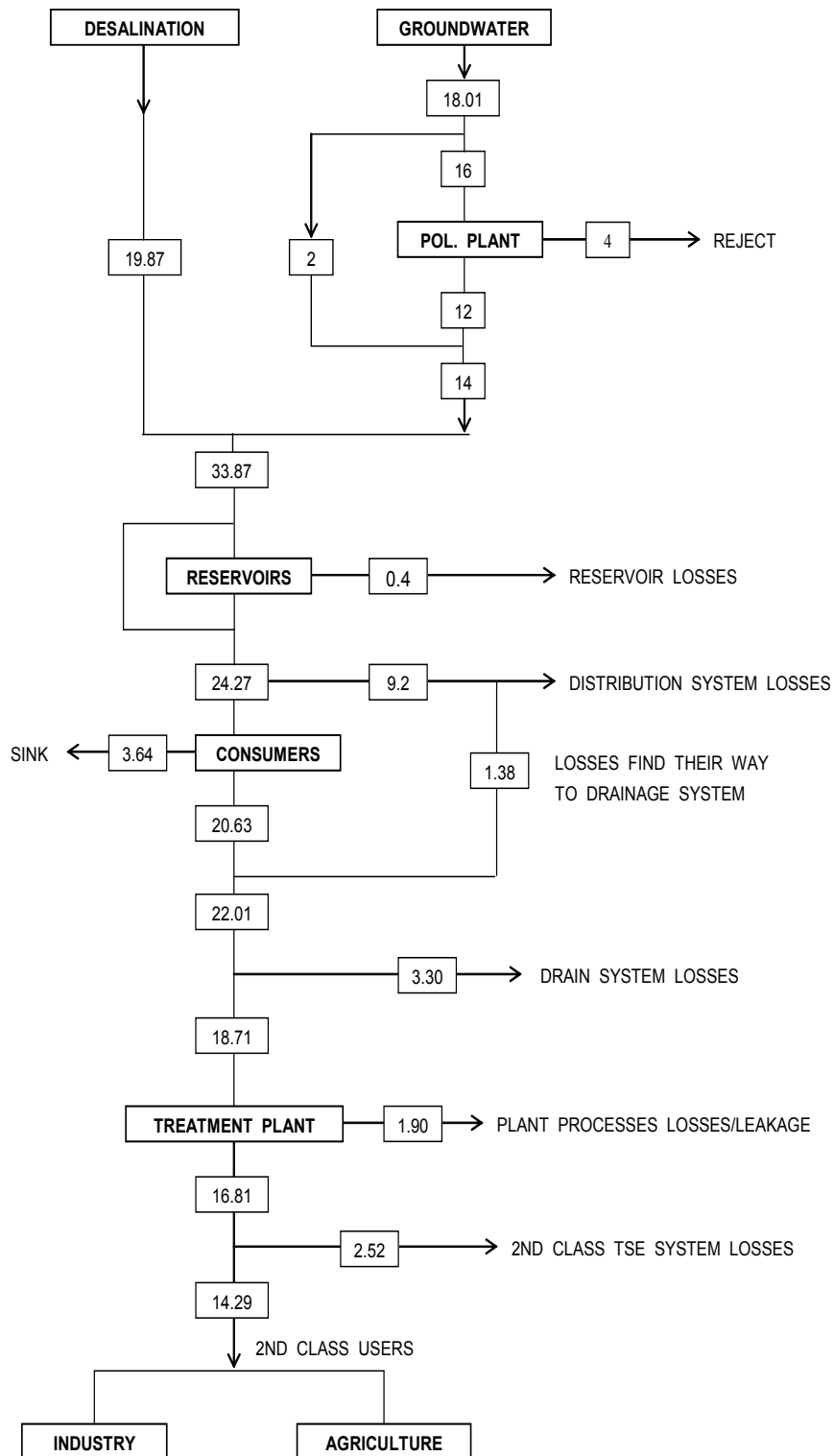

Figure 1. Flow balance showing projected TSE availability based on 2001/2002 figures for water production

4. COST OF TREATED SEWAGE EFFLUENT

The cost of the treatment plants is shown in Table 3 in the respective component cost for mechanical installation, electrical installation and civil works. Civil works are depreciated over 12.5 years at 2 % per annum while mechanical and Electrical works are depreciated at 8 % annually (Delia, 2004). The projected cost per m³ of TSE produced by every plant and the average cost of the

three plants are given in Table 4. This cost does not include polishing with RO to reduce salinity of the treated product. Neither does the cost include that for sludge disposal. Up till now there is no reliable data on the cost of disposing sludge in an environmentally safe manner. Further studies are needed to identify the most cost-effective method of disposal in the light of its possible use as a soil conditioner.

Table 3. Estimated cost of sewerage treatment plant (in million Euros)

	Gozo	North	South
Capital cost	7.2	7.5	60.0
Operational and maintenance	0.467	0.467	2.034
Administration	N.A	N.A	N.A
Depreciation W/E installation	0.072	0.075	2.034
Depreciation civil works	0.288	0.3	2.4

Source: Water Service Corporation, 2003

Table 4. Cost of TSE Per plant (in Euros)

Plant	Tertiary treatment effluent price of production per m ³	Secondary treated effluent price of production per m ³
Gozo	0.32	0.25
North	0.34	0.27
South	0.126	0.10
All flows	0.16	NA

Source: Water Services Corporation, 2004

5. CHEMICAL QUALITY ISSUES

One of the limiting factors that constrains the re-usability of TSE is its chemical quality. Sewage in Malta is known to have a high saline content that will not be removed by conventional treatment to tertiary stage. Hence a suitable desalting process must be applied downstream of the plant if the product is to be utilised safely for agriculture. Reverse Osmosis (RO) is one of the most favoured and cost effective methods with which the treated product may be desalted to less than 300mg/l TDS.

Considerable expertise in desalination technology is today available in Malta. Synergies can be gained through its useful application and knowledge transfer to the sewage treatment sector in order to ensure that the most cost-effective process is applied for the purpose of producing an effluent that can be economically utilised by a wide sector of the community.

Recent technological development with Membrane Bioreactors has lead to remarkable applications to sewage treatment and is considered relevant to the subject of this paper. MBR systems utilise a bioreactor and micro filtration as one unit process for wastewater treatment thereby replacing, the secondary clarification stage and effluent filtration in conventional treatment. Furthermore the high quality effluent produced by MBR renders it highly suitable as a sewage treatment process that may be integrated with an RO unit to produce an effluent of good salinity standards. We believe that coupled MBR-RO systems will be largely employed in future, in conditions where a high quality product is intended for re-use by various applications.

6. IRRIGATION DEMAND

While there are no measurements of the total volume of water used for irrigation, it is accepted that most of the requirement is today being met from groundwater sources. Recent estimates are based on official statistical data of irrigated land and declared crop production. In both cases the overall irrigation demand is estimated on the basis of crop-water requirement calculated by standard empirical methods. Two sources of data were used to reach a plausible estimate: the 2001 *Agricultural Census* and the 2003 *Farm Structure Survey* both conducted by NSO.

Results show that the current irrigation demand to support the present agricultural land ranges between 13 and 16 Mm³/annum. As around 80% of this demand is met from groundwater sources, the resulting pressure on the aquifers cannot be ignored. Future sustainability of agriculture is hinged

to the availability of freshwater, thus stressing the urgent need to identify non-conventional sources that can safely substitute present abstraction from the aquifers – a process that will lead to a gradual recovery of the status groundwater bodies.

7. OBSERVATIONS ON FUTURE AVAILABILITY OF TREATED SEWAGE EFFLUENT IN NORTHERN AND SOUTHERN MALTA

7.1. The North

The Estimated sewage flows to the Cumnija Treatment Plant are approximately 4200 m³/day. Taking into account the treatment plant rejects and distribution system losses (10 % and 15 % of the flow respectively), the supply of treated effluent would be of the order of 3,200 m³/day. This would provide around 1.2 Mm³ of TSE annually. Current irrigation demand in the area is estimated to be around 1 Mm³, irrigating an approximate area of 100 ha of vegetable cultivations (with a 40 % double cropping intensity), 30 ha of vineyards and 15 ha of orchards.

If the dry arable land in the region measuring around 350 ha were to be reclaimed for agriculture the additional irrigation demand, estimated on the basis of utilizing all the available arable land with a 40 % double cropping intensity, would require a further 0.6 Mm³ during the winter period and 1 Mm³ during the summer period, thus exceeding plant capacity in summer. Hence, land reclamation for agriculture in the North merits further consideration to ensure that the resulting irrigation demand in summer, will be easily met by this treatment plant.

7.2. The Southern Region

On the other hand, the Wied Ghammieg Treatment Plant, located in the southern regions of Malta, will produce an estimated supply of 9 Mm³ of treated effluent annually. This would include the 2 Mm³ of treated effluent which is currently being produced annually in the region at the Sant'Antin STP – thus signifying an increase in supply of 7 Mm³. The region which comprises the Zabbar, Xghajra, Zejtun, Marsaxlokk and Marsascula local councils contains around 675 ha of dry arable land; which would produce an additional maximum irrigation demand of 1.2 Mm³ during the winter period and 2 Mm³ during the summer period (assuming a 40 % double cropping intensity). This treatment plant will thus be producing a larger volume than that potentially required for irrigation in the region.

It is therefore necessary to set up a dedicated distribution network to enable a reliable delivery of the TSE to areas where it can gainfully used by agriculture and industry. Capital investment and operational and maintenance cost of the network need to be taken into consideration when setting the price of the effluent, distributed to consumers in these areas.

8. ISSUES OF RELEVANCE IN TSE APPLICATION

The utilisation of Treated Sewage Effluent (TSE) for agriculture must be treated with caution and in full consideration of public health issues. The impact of treated sewage effluent on the aquifers by its application either through irrigation or by direct recharge, is constrained by hydrogeological conditions, the quality of the effluent and the cost of treatment.

The degradation and/or elimination of microbiological pollutants from surface recharge is directly related to travel time in the unsaturated zone and detention in the aquifer before abstraction. The Maltese aquifers are geologically composed of fractured and weathered limestone having a high permeability. Moreover they are unconfined and highly prone to rapid infiltrations from the surface. Soil cover barely exceeds half a metre in thickness thus reducing further the possibility of filtering or eliminating pollutants.

Surface infiltrations therefore travel directly from the surface into the aquifers through numerous faults and fissures that intersect the rock strata, in a relatively short time. Purification in these circumstances is minimal if non-existent. Vulnerability of the aquifers modelled on recent physical and

hydrogeological data shows the aquifer to be vulnerable in most places and highly susceptible to any form of surface activity.

Furthermore the short residence time for surface infiltrations before abstraction, places further constraints. Our territorial limitations do not allow the application of TSE on areas sufficiently far to ensure a safe lag time before re-abstraction. Practice in other countries imposes a retention time in the aquifer from six to twelve months depending on the intended use. Abstraction for potable purposes is however never practiced.

As a general rule TSE used for surface infiltration must be of a superior quality than the aquifer beneath the point of application. Our two main aquifers are known to be depleted, and while benefit may be derived with respect to certain ions like nitrates and chlorides, it is not known whether any substance/organism hitherto unknown will appear in the long term with ill effects to public health.

Viruses are the main point of concern and the major fear expressed by the Ministry of Health. Some cases of human infection through wrong application of TSE have been reported elsewhere, in the past, and it is the responsibility of planners and decision-makers to protect the community from the effects of similar mal-practice.

In view of the aforementioned considerations, and with the available knowledge to date, it is desirable to utilise, for the time being, TSE microbiologically purified TSE exclusively in those areas where flow gradients in the aquifer are directed towards the shoreline and away from abstraction points, and/or where groundwater quality is known to be poor in quality and not exploited for drinking purposes.

9. CONCLUSIONS

On the basis of the aforementioned observations the following conclusions can be drawn:

- a) TSE offers a potential alternative to freshwater used for irrigation of crops in Malta, provided it is applied diligently.
- b) The effluent will have to be treated to suitable standards that may involve post treatment by RO to reduce salinity levels of the effluent.
- c) Environmental and health issues are to be taken into consideration by decision-makers when identifying areas for irrigation with TSE.
- d) Cost recovery is an essential requisite to ensure the economic sustainability of the use of this non-conventional resource.

REFERENCES

- Angelakis, Andreas N., *Wastewater Recycling and Reuse in Malta*, FAO & MRA, Nov. 2003
- COWI Consult, 1992, *Malta Sewerage Master Plan for Malta and Gozo, Working Papers 1 and 2*. A report prepared for the Ministry for Development and Infrastructure, Malta.
- Delia, Carmen, 2004, *Economic Considerations Regarding Markets for Water in the Maltese Islands* (Report prepared for the FAO on Water Resources Review for the Maltese Islands)
- Sapiano, E., 2004, *Interim Report on Water Use in the Maltese Islands*
- Water Services Corporation *Published Annual Reports, 2001, 2002 and 2003*
- Malta Resources Authority *Published Annual Reports 2002, 2003*