



L-Università
ta' Malta

MATSEC
Examinations Board



Specimen Papers
SEC23 Mathematics

Table of Contents

Specimen Assessments: Controlled Paper MQF 1-2	3
Specimen Assessments: Marking Scheme for Controlled Paper MQF 1-2	12
Specimen Assessments: Controlled Paper MQF 2-3	17
Specimen Assessments: Marking Scheme for Controlled Paper MQF 2-3	26
Specimen Assessments: Controlled Paper MQF 3-3*	30
Specimen Assessments: Marking Scheme for Controlled Paper MQF 3-3*	40
Specimen Assessments: Private Candidates Controlled Paper MQF 1-2-3.....	45
Specimen Assessments: Marking Scheme for Private Candidates Controlled Paper MQF 1-2-3	58

Specimen Assessments: Controlled Paper MQF 1-2



L-Università
ta' Malta

MATRICULATION AND SECONDARY EDUCATION CERTIFICATE
EXAMINATIONS BOARD

SECONDARY EDUCATION CERTIFICATE LEVEL SAMPLE CONTROLLED PAPER

SUBJECT: **Mathematics**
PAPER NUMBER: **Level 1 – 2**
DATE:
TIME: 2 hours

Answer **ALL** questions.

Write your answers in the space available on the examination paper.

Show clearly all the necessary steps, explanations and construction lines in your working.

Unless otherwise stated, diagrams are drawn to scale.

The use of non-programmable electronic calculators with statistical functions and mathematical instruments is allowed.

Candidates are allowed to use transparencies for drawing transformations.

This paper carries 100 marks.

1. Liam, Sandra and Jillian find the following recipe for 12 scones on the internet:

400 g flour	170 g butter
70 g sugar	1 egg
2 teaspoons baking powder	250 ml milk
$\frac{1}{2}$ teaspoon salt	

a) Underline the best estimate for the total weight of all the ingredients?

893 $\frac{1}{2}$ g 1 kg 1500 g 2.5 kg

(3)

b) Liam uses 1 litre of milk to make a number of scones. How much sugar does he use?

(2)

c) Sandra makes 24 scones. How much flour does she use?

(2)

d) Jillian uses 105 g of sugar. How many scones does she make?

(2)

(Total: 9 marks)

2. a) Enter the missing values to complete the following sequence:

7, 7.25, _____, 7.75, _____, _____, 8.5.

(3)

b) i. Write the number seven hundred fifty-four thousand and fifty-eight in figures.

ii. Calculate the difference between the two values of the digit "5" in the number seven hundred fifty-four thousand and fifty-eight.

(4)

c) Use < , > or = to compare the following pairs:

i. $\frac{1}{4}$ $\frac{1}{3}$ ii. $\frac{3}{4}$ 0.75 iii. 0.5 0.4

(3)

d) Write a number that lies between 0.5 and 0.75.

(1)

(Total: 11 marks)

3. Work out the size of the angles marked x , y and z .

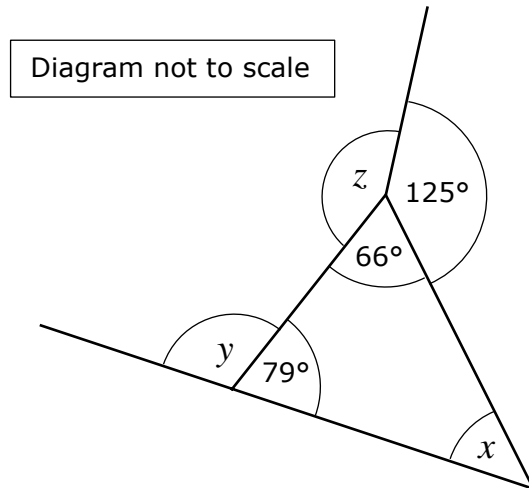

(6)

(Total: 6 marks)

4. a) Complete the shape to make it symmetrical about the dotted line.

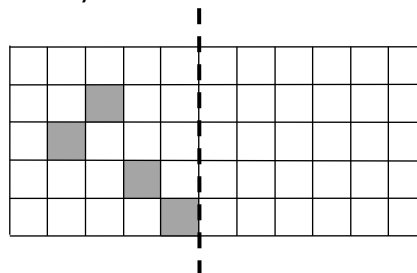

(2)

b) i. Reflect shape A in the horizontal dotted line. Label the image B.
ii. Now reflect A and B in the vertical dotted line.

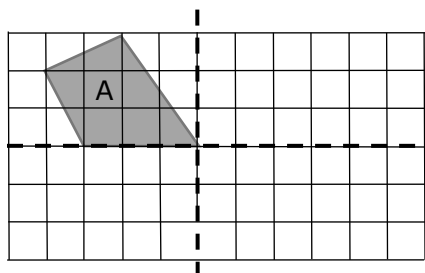

(3)

c) i. Move point A: 5 right and 2 up. Label it A_1 .
ii. Move point B: 9 left and 3 down. Label it B_2 .

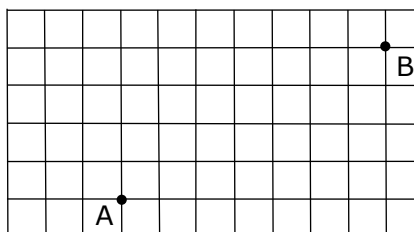

(2)

(Total: 7 marks)

5. a) Sort the following numbers in the Carroll diagram:
1, 4, 7, 8, 12, 16, 27, 36, 64

	Square numbers	Not square numbers
Cube numbers		
Not cube numbers		

(3)

- b) From the following set of numbers,
2, 5, 9, 13, 17, 19, 26, 30:

i. choose **THREE** numbers that add up to 60;

ii. calculate the mean of **all** the odd numbers.

(1)

(3)

(Total: 7 marks)

6. a) Martin and Claire are playing a game. They roll two fair dice, each numbered 1 to 6 and the score is the **product** of the two numbers. Show **all** the possible outcomes in the possibility space below:

		1 st Dice					
		1	2	3	4	5	6
2 nd Dice	1	1		3			
	2						
	3			9			
	4						24
	5						
	6		12				



(2)

- b) What is the probability that the score is:

i. 15?

(1)

ii. a factor of 80?

(2)

iii. a multiple of 3?

(2)

- c) Which **TWO** scores have the greatest probability? (1)
- d) List **all** the different possible scores. (2)
- e) Which score has a probability of $\frac{1}{12}$? (2)

(Total: 12 marks)

7. The side AC of a scalene triangle ABC is x cm long.
Side BC is 3 cm longer than side AC.

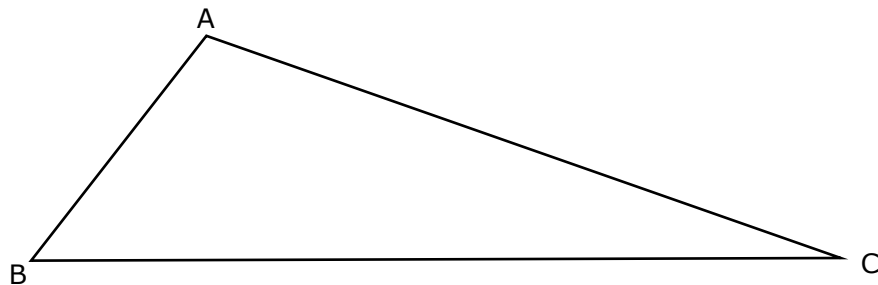

- a) Write an expression for the length of side BC in terms of x . (1)
- b) Side AB is 4 cm shorter than side AC. Write an expression for the length of side AB in terms of x . (1)
- c) The perimeter of the triangle is 26 cm. Write an equation in terms of x and solve it. (1)
- d) Write down the lengths, of the three sides of the triangle ABC. (3)
- AC = _____ cm AB = _____ cm BC = _____ cm (2)

(Total: 7 marks)

8. 271 school children and 11 teachers are going on a school trip. Coaches that carry 51 passengers cost €80 and minivans that carry 14 passengers cost €30. For the school trip, the school cannot spend more than €475 for transport.

a) i. If only coaches are used, how many coaches will be completely full?

(2)

ii. How many passengers will remain?

(2)

b) Show that the school cannot afford to hire another coach.

(2)

c) i. If the school hires minivans to carry those who remain, how many minivans are needed?

(2)

ii. Calculate the total cost of the transport.

(2)

(Total: 10 marks)

9. Chantelle went on holiday in Sweden and Norway. Before departing from Malta, she bought 6000 Swedish Krona (SEK) and 5000 Norwegian Krone (NOK). The exchange rates, at the time, were 10.4769 SEK and 9.6122 NOK, both for one Euro.

a) Find the value of 1 NOK in Euro cent, to the nearest cent.

(2)

b) Calculate the total amount, to the nearest Euro, that Chantelle paid when buying the foreign currency notes.

(3)

c) When she was in Sweden, Chantelle bought a dress that cost €329.00. What is the price that Chantelle paid in SEK?

(2)

(Total: 7 marks)

10. The compound shape in the diagram is made up of a semicircle, a trapezium and a rectangle.

Diagram not to scale

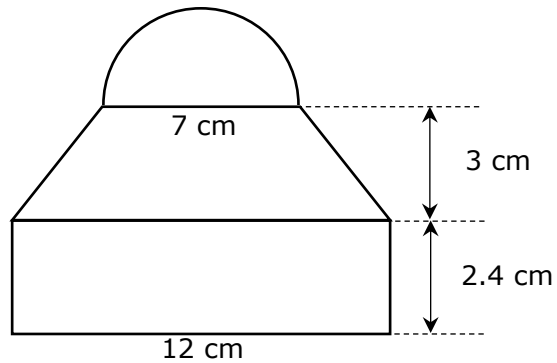

- a) What is the radius of the semicircle? (1)
- b) Calculate the area of the semicircle. (Use $\pi = \frac{22}{7}$) (2)
- c) Calculate the area of the trapezium. (2)
- d) Calculate the total area of the compound shape. (2)

(2)

(Total: 7 marks)

11. a) Complete the table for the graph of the equation $y = 2x - 1$.

x	-1	0	1	2	3
y					

(2)

- b) Draw the graph of $y = 2x - 1$

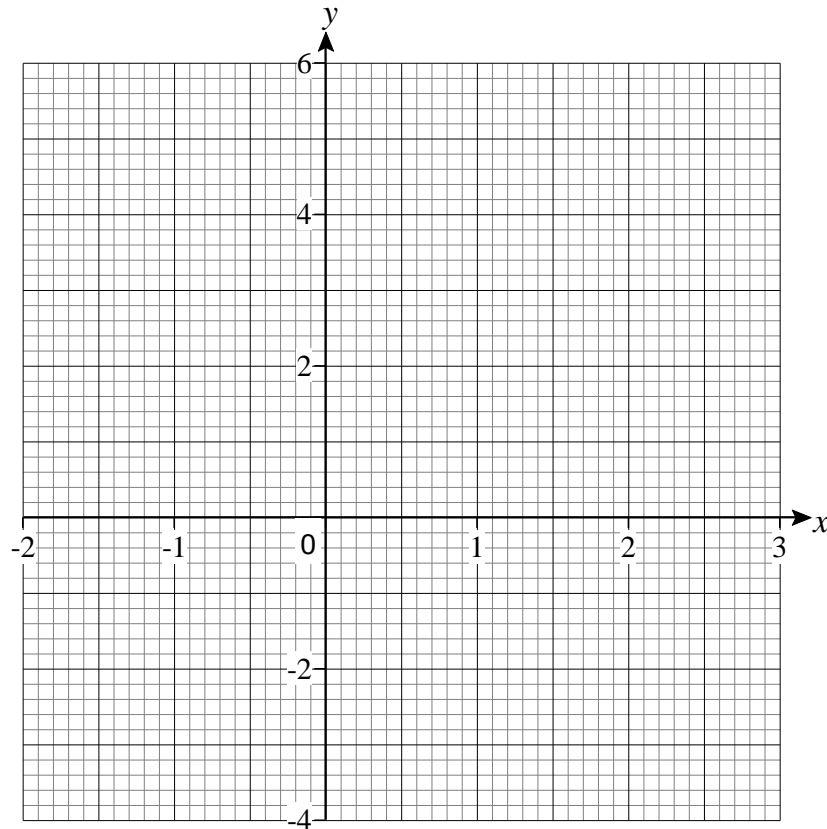

(2)

- c) Use your graph to find the value of:

i. y when $x = 2.6$

ii. x when $y = -4$

(1,1)

- d) Draw a second straight line graph that passes through the two points $(2, -4)$ and $(-1, 5)$.

(1)

- e) Write down the y -intercept of this graph.

(1)

- f) Write down the coordinates of the point of intersection of the two graphs.

(1)

(Total: 9 marks)

-
12. a) In this question, use ruler and compasses only.
- i. Construct a circle of radius 4 cm. (1)
 - ii. Construct a regular hexagon with its vertices on the circumference of the circle. Label the vertices of the hexagon A, B, C, D, E and F. (2)

iii. Draw and measure the diameter AD and the chord CE. (2)

b) Take accurate measurements to calculate the area of the hexagon.

(3)

(Total: 8 marks)

END OF PAPER



L-Università
ta' Malta

MATRICULATION AND SECONDARY EDUCATION CERTIFICATE
EXAMINATIONS BOARD

**SECONDARY EDUCATION CERTIFICATE LEVEL
MARKING SCHEME FOR SAMPLE CONTROLLED PAPER**

SUBJECT: **Mathematics**

PAPER NUMBER: **Level 1 – 2**

DATE:

TIME: 2 hours

Question No.	Workings and Solutions	Additional guidance	Marks
1.	a) Approximate weight of milk: 250 g Approximate weight of egg: 60 g Approximate weight of baking powder and salt: 10 g Total weight = 400 + 70 + 170 + 250 + 60 + 10 = 960 g \approx 1 kg	For approximations Converting g to kg	M1 M1 A1
	b) $(1000 \div 250) \times 70 = 280$ g		M1 A1
	c) 24 scones mean double ingredients Double flour = 800 g		M1 A1
	d) $\frac{12 \times 105}{70} = 18$ scones		M1 A1
(Total: 9 marks)			
2.	a) 7.5 ; 8 ; 8.25		B3
	b) a) 754,058 or 754058 b) 50,000 – 50 = 49,950	Correct 50,000 & 50	B1
			B1 B1 B1
	c) i. $\frac{1}{4} < \frac{1}{3}$ ii. $\frac{3}{4} = 0.75$ iii. $0.5 > 0.4$		B1
		B1	
		B1	
d) Any number between 0.5 and 0.75		B1	
(Total: 11 marks)			
3.	$x = 180^\circ - 79^\circ - 66^\circ = 35^\circ$		M1 A1
	$x = 180^\circ - 79^\circ = 101^\circ$		M1 A1
	$z = 360^\circ - 66^\circ - 125^\circ = 169^\circ$		M1 A1
(Total: 6 marks)			

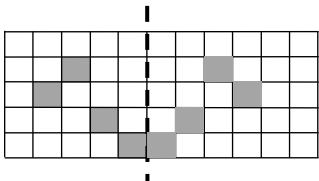
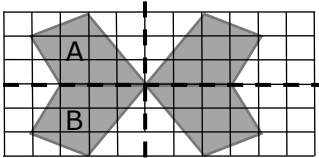
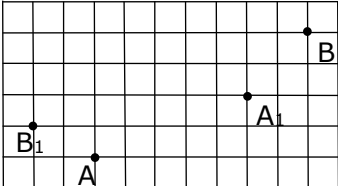
4.	a)		1 mark for each two correct squares	B2	
	b)	i. ii.		1 mark for each correct reflection	B1 B2
	c)	i. ii.			B1 B1

(Total: 7 marks)

5.	a)	<table border="1" data-bbox="296 920 908 1162"> <thead> <tr> <th></th> <th>Square numbers</th> <th>Not square numbers</th> </tr> </thead> <tbody> <tr> <td>Cube numbers</td> <td>1 64</td> <td>8 27</td> </tr> <tr> <td>Not cube numbers</td> <td>4 16 36</td> <td>7 12</td> </tr> </tbody> </table>		Square numbers	Not square numbers	Cube numbers	1 64	8 27	Not cube numbers	4 16 36	7 12	(-1 e.e.o.o.)	B3
		Square numbers	Not square numbers										
Cube numbers	1 64	8 27											
Not cube numbers	4 16 36	7 12											
b)	i. 13, 17 and 30 ii. $(5 + 9 + 13 + 17 + 19) \div 5 = 12.6$		Correct odd numbers For adding and dividing	B1 M1 M1 A1									

(Total: 7 marks)

6.	a)	<table border="1" data-bbox="312 1473 922 1742"> <thead> <tr> <th colspan="2"></th> <th colspan="6">1st Dice</th> </tr> <tr> <th colspan="2"></th> <th>1</th> <th>2</th> <th>3</th> <th>4</th> <th>5</th> <th>6</th> </tr> </thead> <tbody> <tr> <th rowspan="6">2nd Dice</th> <th>1</th> <td>1</td> <td>2</td> <td>3</td> <td>4</td> <td>5</td> <td>6</td> </tr> <tr> <th>2</th> <td>2</td> <td>4</td> <td>6</td> <td>8</td> <td>10</td> <td>12</td> </tr> <tr> <th>3</th> <td>3</td> <td>6</td> <td>9</td> <td>12</td> <td>15</td> <td>18</td> </tr> <tr> <th>4</th> <td>4</td> <td>8</td> <td>12</td> <td>16</td> <td>20</td> <td>24</td> </tr> <tr> <th>5</th> <td>5</td> <td>10</td> <td>15</td> <td>20</td> <td>25</td> <td>30</td> </tr> <tr> <th>6</th> <td>6</td> <td>12</td> <td>18</td> <td>24</td> <td>30</td> <td>36</td> </tr> </tbody> </table>			1 st Dice								1	2	3	4	5	6	2 nd Dice	1	1	2	3	4	5	6	2	2	4	6	8	10	12	3	3	6	9	12	15	18	4	4	8	12	16	20	24	5	5	10	15	20	25	30	6	6	12	18	24	30	36		
				1 st Dice																																																											
		1	2	3	4	5	6																																																								
2 nd Dice	1	1	2	3	4	5	6																																																								
	2	2	4	6	8	10	12																																																								
	3	3	6	9	12	15	18																																																								
	4	4	8	12	16	20	24																																																								
	5	5	10	15	20	25	30																																																								
	6	6	12	18	24	30	36																																																								
			deduct 1 mark for every three incorrect entries	B2																																																											

	b)	i. $\frac{1}{18}$ ii. factors of 80: 1, 2, 4, 5, 2, 4, 8, 10, 4, 8, 16, 20, 5, 10 and 20. $= \frac{15}{36} = \frac{5}{12}$ iii. multiples of 3: 3, 6, 6, 12, 3, 6, 9, 12, 15, 18, 12, 24, 15, 30, 6, 12, 18, 24, 30 and 36. $= \frac{20}{36} = \frac{5}{9}$	Or equivalent For identifying factors of 80 Or equivalent For identifying multiples of 3 Or equivalent	B1 M1 A1 M1 A1
	c)	6 and 12		B1
	d)	Different scores: 1, 2, 3, 4, 5, 6, 8, 10, 12, 9, 15, 18, 16, 20, 24, 25, 30 and 36. 18	For identifying the scores	M1 A1
	e)	$\frac{1}{12} = \frac{3}{36}$ and there are three 4's. The score is 4		M1 A1
(Total: 12 marks)				
7.	a)	$x + 3$		B1
	b)	$x - 4$		B1
	c)	$x + x + 3 + x - 4 = 26$ $3x = 27$ $x = 9$	or equivalent	B1 M1 A1
	d)	9 cm ; 5 cm ; 12 cm		B2
(Total: 7 marks)				
8.	a)	i. $282 \div 51 = 5.52\dots$ 5 Coaches ii. $282 \div 51 = 5$ remainder 27 27 passengers		M1 A1 M1 A1
	b)	$80 \times 6 = 480$ €480 is more than €475		M1 A1
	c)	i. $27 \div 14 = 1.92\dots$ 2 minivans ii. $80 \times 5 + 30 \times 2 = €460$		M1 A1 M1 A1
(Total: 10 marks)				
9.	a)	$1 \div 9.6122 = €0.104\dots$ = 10 cent		M1 A1
	b)	$(6000 \div 10.4769) + (5000 \div 9.6122)$ = 1092.8607... = €1093		M1 M1 A1
	c)	329.00×10.4769 = 3446.90 SEK		M1 A1
(Total: 7 marks)				

10.	a)	3.5 cm or 3 ½ cm		B1
	b)	$A = \frac{\pi r^2}{2}$ $A = \frac{22}{7} \times (3.5)^2 \div 2$ $= 19.25 \text{ cm}^2$		M1 A1
	c)	$A = \frac{h(a+b)}{2}$ $A = \frac{3(12+7)}{2}$ $= 28.5 \text{ cm}^2$		M1 A1
	d)	Area of rectangle = 28.8 Total area = 28.8 + 19.25 + 28.5 $= 76.55 \text{ cm}^2$		M1 A1

(Total: 7 marks)

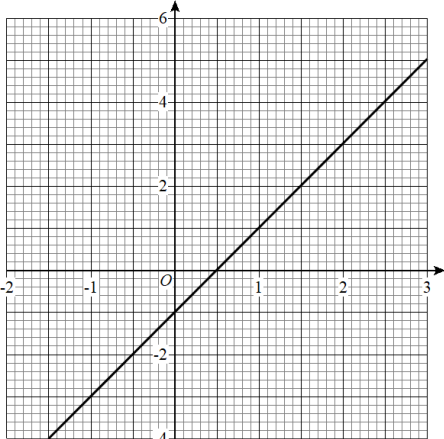
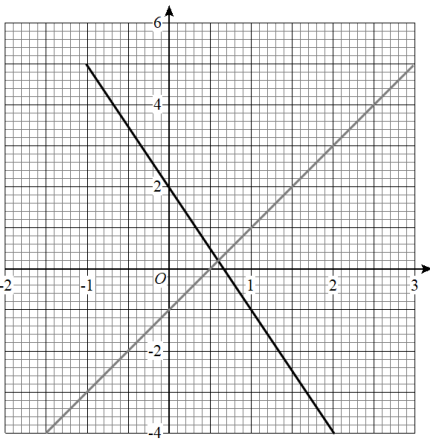
11.	a)	<table border="1" style="display: inline-table; vertical-align: middle;"> <tr> <td>x</td> <td>-1</td> <td>0</td> <td>1</td> <td>2</td> <td>3</td> </tr> <tr> <td>y</td> <td>-3</td> <td>-1</td> <td>1</td> <td>3</td> <td>5</td> </tr> </table>	x	-1	0	1	2	3	y	-3	-1	1	3	5	(-1 e.e.o.o.)	B2
	x	-1	0	1	2	3										
	y	-3	-1	1	3	5										
	b)		Correct plotting of points Correct line	B1 B1												
	c)	i. 4.2 ii. -1.5		B1 B1												
	d)			B1												
e)	2		B1													
f)	(0.6, 0.2)	1 mark for the x-coordinate and 1 mark for the y-coordinate	B1													

(Total: 9 marks)

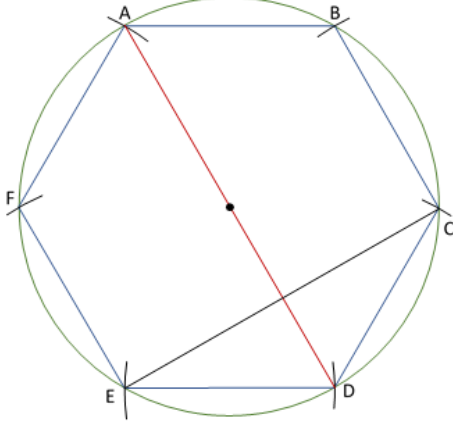
12.	a)	i. ii.  iii. AD = 8 cm; CE = 6.9 cm	Circle of radius 4 cm Correct construction of arcs and hexagon CE ± 0.2 cm	B1 B2 B1 B1
	b)	Perpendicular distance between two parallel sides of trapezium = 3.45 cm Area of hexagon = 2 × area of trapezium $= 2 \times \frac{1}{2} \times 3.45 \times (4 + 8) = 41.4 \text{ cm}^2$		M1 M1 A1(ft)
(Total: 8 marks)				

Specimen Assessments: Controlled Paper MQF 2-3



L-Università
ta' Malta

MATRICULATION AND SECONDARY EDUCATION CERTIFICATE
EXAMINATIONS BOARD

**SECONDARY EDUCATION CERTIFICATE LEVEL
SAMPLE CONTROLLED PAPER**

SUBJECT: **Mathematics**
PAPER NUMBER: **Level 2 – 3**
DATE:
TIME: 2 hours

Answer **ALL** questions.

Write your answers in the space available on the examination paper.

Show clearly all the necessary steps, explanations and construction lines in your working.

Unless otherwise stated, diagrams are drawn to scale.

The use of non-programmable electronic calculators with statistical functions and mathematical instruments is allowed.

Candidates are allowed to use transparencies for drawing transformations.

This paper carries 100 marks.

1. a) i. What is the least common multiple of 4, 6 and 8?

ii. Use equivalent fractions to put $\frac{5}{8}$, $\frac{5}{6}$ and $\frac{3}{4}$ in ascending order. (2)

b) The planet Saturn has a mass of 5.7×10^{26} kg and the planet Jupiter has a mass of 1.9×10^{27} kg. (2)

i. How much is Jupiter heavier than Saturn? Write your answer in standard form.

ii. The mass of Saturn is $\frac{a}{b}$ the mass of Jupiter. Write down the fraction $\frac{a}{b}$ where a and b are whole numbers. (2)

(2)

(Total: 8 marks)

2. The side AC of a scalene triangle ABC is x cm long.

Side BC is 3 cm longer than side AC.

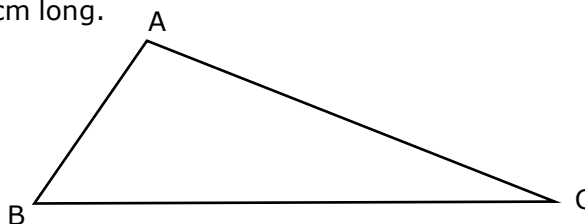

a) Write an expression for the length of side BC in terms of x .

(1)

b) Side AB is 4 cm shorter than side AC. Write an expression for the length of side AB in terms of x .

(1)

c) The perimeter of the triangle is 26 cm. Write an equation in terms of x and solve it.

(3)

d) Write down the lengths, in cm, of each of the three sides of the triangle ABC.

AC =

AB =

BC =

(2)

(Total: 7 marks)

3. 271 school children and 11 teachers are going on a school trip. Coaches that carry 51 passengers cost €80 and minivans that carry 14 passengers cost €30. For the school trip, the school cannot spend more than €475 for transport.

a) i. If only coaches are used, how many coaches will be completely full?

ii. How many passengers will remain?

(2)

b) Show that the school cannot afford to hire another coach.

(2)

c) i. If the school hires minivans to carry those who remain, how many minivans are needed?

(2)

ii. Calculate the total cost of the transport.

(2)

(2)

(Total: 10 marks)

4. Chantelle went on holiday in Sweden and Norway. Before departing from Malta, she bought 6000 Swedish Krona (SEK) and 5000 Norwegian Krone (NOK). The exchange rates, at the time, were 10.4769 SEK and 9.6122 NOK, both for one Euro.

a) Find the value of 1 NOK in Euro cent, to the nearest cent.

b) Calculate the total amount, to the nearest Euro, that Chantelle paid when buying the foreign currency notes.

(2)

(3)

- c) While in Sweden, Chantelle lost her mobile phone, which she had bought in Malta for €350.00. She bought another one, of the same model, for 5000 SEK. Calculate the percentage difference, in the price of the new mobile phone, over its cost in Malta. Give your answer correct to 2 decimal places.

(4)

(Total: 9 marks)

5. Bernard would like to visit friends in Canada and looks for possible flights offered by different airlines. The following are the times of flights for each itinerary, local time. (Local time means the time of the city from which the plane is leaving or at which it is arriving). Toronto is 6 hours and London is 1 hour, behind Central European Time. Malta, Munich and Vienna are in the Central European Time zone. The flight from London to Toronto takes 7 hours 10 minutes.

	Departure	Time	Arrival	Time	Departure	Time	Arrival	Time
A	Malta	16:50	Munich	19:20	Munich	11:50	Toronto	14:40
B	Malta	07:20	Vienna	09:35	Vienna	10:30	Toronto	13:55
C	Malta	07:15	London	10:20	London	?	Toronto	15:05

- a) Calculate the departure time from London.

(2)

- b) How long is the waiting time at London airport?

(1)

- c) Work out the total time that elapses, between leaving Malta and arriving in Toronto, for itineraries A and B. Give your answer in hours and minutes.

A:

B:

(5)

- d) What is the difference in total duration of the journey between the itinerary offered by airline B and that offered by airline C? Give your answer in hours and minutes.

(2)

(Total: 10 marks)

6. The stacked bar chart below shows the number of different staff employed with a firm in the years 2016, 2017 and 2018.

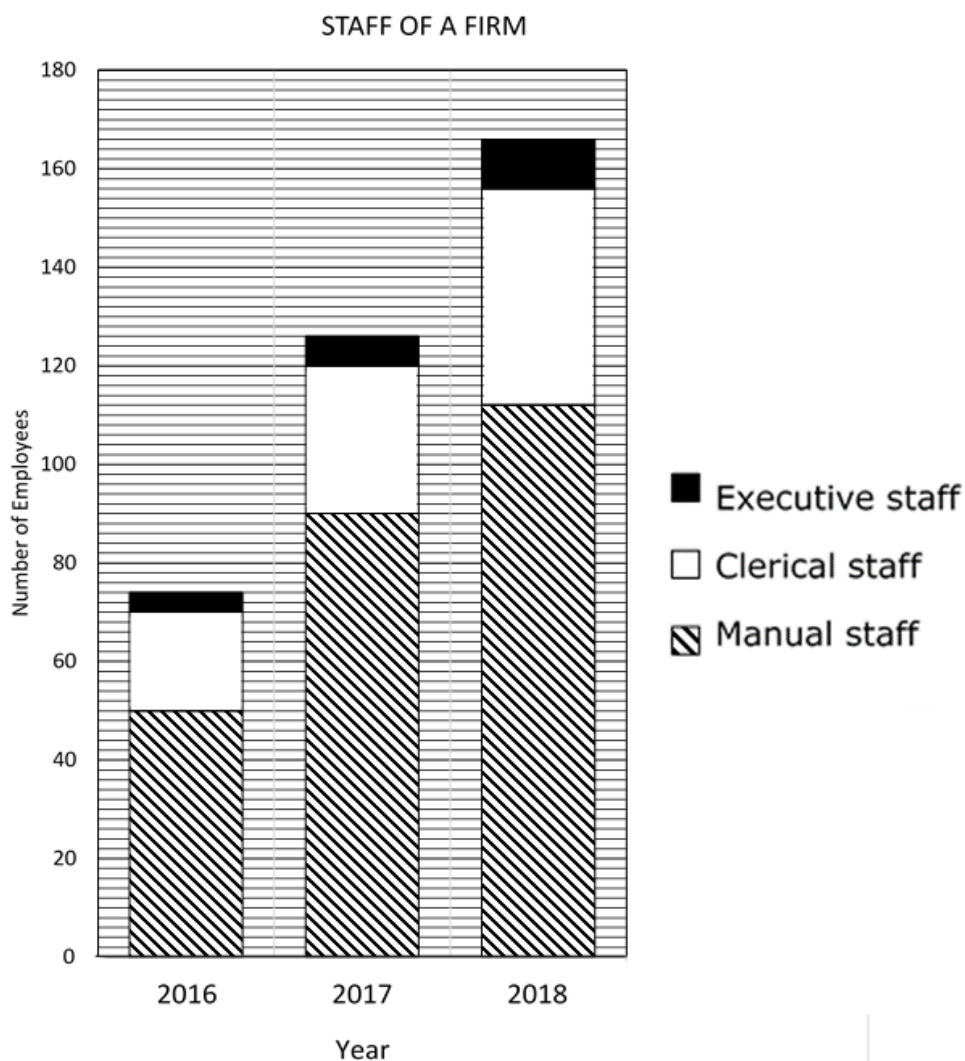

- a) What fraction of the total staff in 2016 consisted of Clerical staff?

(2)

- b) Calculate the increase in Manual staff between 2017 and 2018.

(1)

- c) A report in the company magazine stated that, for each clerk, there were more manual and executive workers in 2017, than there were in 2018. Show that this report is correct.

(3)

(Total: 6 marks)

7. EDOC is a straight line. DC is a diameter to the circle centre O. The line ABC is the hypotenuse of the right angled triangle AEC.

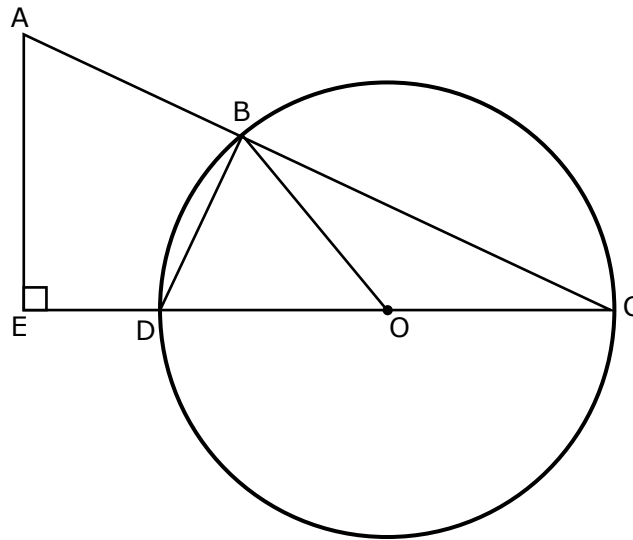

- a) What is the size of angle DBC? Give a reason for your answer.

(1)

- b) Show that ABDE is a cyclic quadrilateral.

(3)

- c) Angle ACE = 30° . Find the size of angle BOD. Give a reason for your answer.

(2)

(Total: 6 marks)

8. a) Use ruler and compasses only to construct a triangle ABC such that $BC = 10$ cm, angle $ABC = 45^\circ$ and angle $ACB = 60^\circ$.

- b) Construct the perpendicular bisectors of lines AB and BC. Label the point O where these two perpendicular bisectors meet. (4)
- c) Draw the locus of the point which is 5.2 cm from O. (2)

(Total: 8 marks)

9.

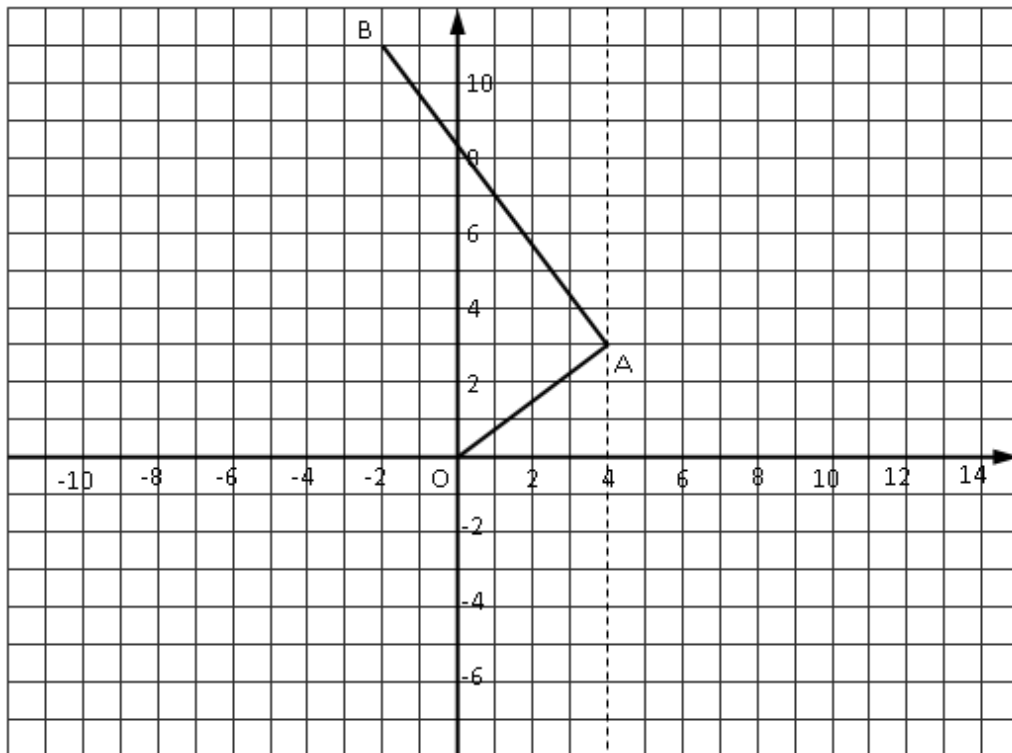

- a) Mark a point C to complete the rectangle OABC. Draw the rectangle OABC. (1)
- b) Draw and label the reflection of OABC in the line $x = 4$, to form rectangle $O_1A_1B_1C_1$. (2)

- c) Rotate rectangle $OABC$ 90° anticlockwise about the origin to form $OA_2B_2C_2$. Draw and label rectangle $OA_2B_2C_2$. (4)

(Total: 7 marks)

10. The following distance - time graph shows the journey of a man who went for a walk.

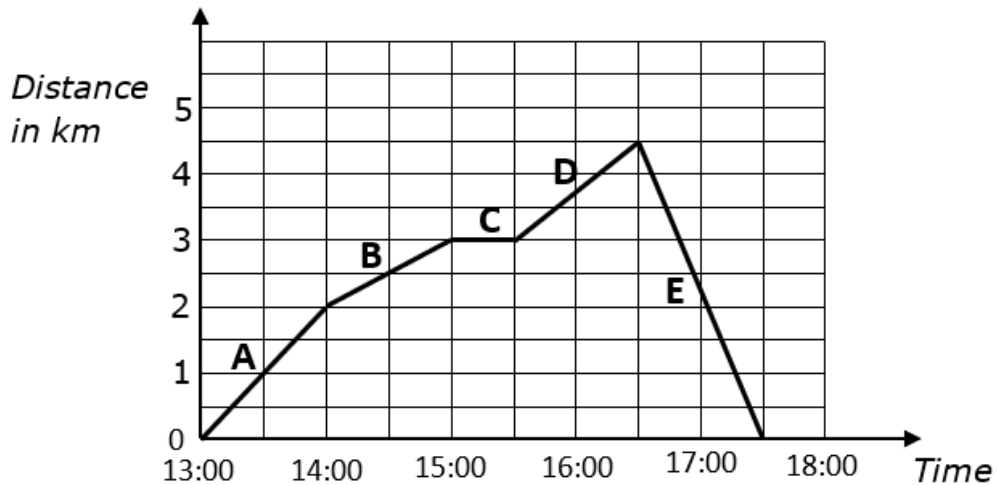

- a) How far did he travel altogether? (2)
- b) Calculate his average speed in km/h. (3)
- c) For how long did he stop? (1)
- d) What does part E represent? (1)
- e) In which stage did he travel fastest? Give a reason for your answer. (2)

(Total: 9 marks)

11. John has a sum of €235 that is made up of 5 euro notes and 20 euro notes. He has twelve more 5 euro notes than 20 euro notes.

- a) Let x be the number of 5 euro notes.
 Let y be the number of 20 euro notes.
 Write down **TWO** equations in terms of x and y to represent the above information.

- b) Find the number of 5 euro notes and the number of 20 euro notes that John has. (2)

(6)

(Total: 8 marks)

12. Alex conducted a survey on the number of people travelling in cars as they passed through a road.

Alex's Morning Survey	
Number of people in a car	Frequency
1	144
2	70
3	16
4	10

- a) How many cars were surveyed? (1)
- b) How many people passed through the road while travelling in these cars? (2)
- c) What is the mean number of people per car? (2)
- d) What is the probability that a car that passes through the road has 3 or more people travelling in it? (2)
- e) After doing some calculations Alex stated:
"It is equally likely for cars to have less than 3 people travelling in them as for cars to have 3 or more people travelling in them".
- i. Is Alex correct? (1)
- ii. Explain your reasoning. (4)

(4)

(Total: 12 marks)

END OF PAPER

Specimen Assessments: Marking Scheme for Controlled Paper MQF 2-3



**L-Università
ta' Malta**

MATRICULATION AND SECONDARY EDUCATION CERTIFICATE
EXAMINATIONS BOARD

**SECONDARY EDUCATION CERTIFICATE LEVEL
MARKING SCHEME FOR SAMPLE CONTROLLED PAPER**

SUBJECT: **Mathematics**

PAPER NUMBER: **Level 2 – 3**

DATE:

TIME: 2 hours

Question No.	Workings and Solutions	Additional guidance	Marks
1.	a) i. Multiples of 4: 4, 8, 12, 16, 20, 24 Multiples of 6: 6, 12, 18, 24 Multiples of 8: 8, 16, 24 LCM = 24 ii. $\frac{5}{8} = \frac{15}{24}$; $\frac{5}{6} = \frac{20}{24}$; $\frac{3}{4} = \frac{18}{24}$ $\therefore \frac{5}{8}, \frac{3}{4}, \frac{5}{6}$	Equivalent fractions with a same common denominator Correct order	M1 A1 M1 A1
	b) i. $1.9 \times 10^{27} - 5.7 \times 10^{26} = 1.33 \times 10^{27}$ ii. $\frac{5.7 \times 10^{26}}{1.9 \times 10^{27}} = \frac{3}{10}$		M1 A1 M1 A1
(Total: 8 marks)			
2.	a) $x + 3$		B1
	b) $x - 4$		B1
	c) $x + x + 3 + x - 4 = 26$ $3x = 27$ $x = 9$	or equivalent	B1 M1 A1
	d) 9 cm; 5 cm; 12 cm		B2
(Total: 7 marks)			
3.	a) i. $282 \div 51 = 5.52\dots$ 5 coaches ii. $282 \div 51 = 5$ remainder 27 27 passengers		M1 A1 M1 A1
	b) $80 \times 6 = 480$ €480 is more than €475		M1 A1
	c) i. $27 \div 14 = 1.92\dots$ 2 minivans		M1 A1

		ii. $(80 \times 5) + (30 \times 2)$ = €460		M1 A1
(Total: 10 marks)				
4.	a)	$1 \div 9.6122 = €0.104\dots$ = 10 cents		M1 A1
	b)	$(6000 \div 10.4769) + (5000 \div 9.6122)$ = 1092.8607... = €1093		M1 M1 A1
	c)	$5000 \text{ SEK} = 5000 \div 10.4769$ = €477.2404... % Difference = $\frac{477.2404\dots - 350}{350} \times 100$ = 36.35%		M1 A1 M1 A1 (f.t.)
(Total: 9 marks)				
5.	a)	Arrival in Toronto (London Time): $15:05 + 5 \text{ hrs} = 20:05$ Departure from London: $20:05 - 7:10 = 12:55$		M1 A1
	b)	Waiting time in London: $12:55 - 10:20 = 2 \text{ hours } 35 \text{ minutes}$		A1
	c)	Airline A: Arrival in Toronto (Central European time) is $14:40 + 6 \text{ hrs} = 20:40$ Time between 16:50 and 20:40 (next day) = 7 hrs 10 min + 20 hrs 40 min = 27 hrs 50 min Airline B: Arrival in Toronto (Central European time) is $13:55 + 6 \text{ hrs} = 19:55$ Time between 07:20 and 19:55 = 12 hours 35 minutes		M1 M1 A1 M1 A1
	d)	Airline C: Arrival time in Toronto (Central European time): $15:05 + 6 \text{ hrs} = 21:05$ Total time elapsed: $21:05 - 07:15 = 13 \text{ hrs } 50 \text{ min}$ Difference: $13 \text{ hrs } 50 \text{ min} - 12 \text{ hrs } 35 \text{ min}$ = 1 hour 15 minutes		M1 A1
(Total: 10 marks)				
6.	a)	20 clerks out of 74 $\frac{10}{37}$		M1 A1
	b)	$112 - 90 = 22$		B1

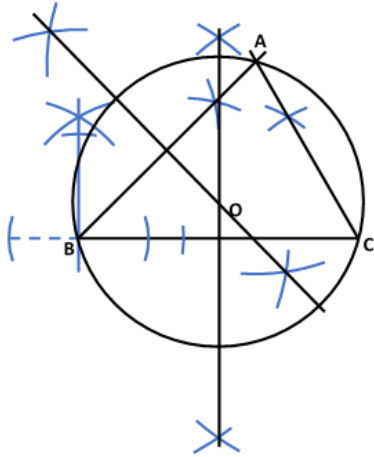
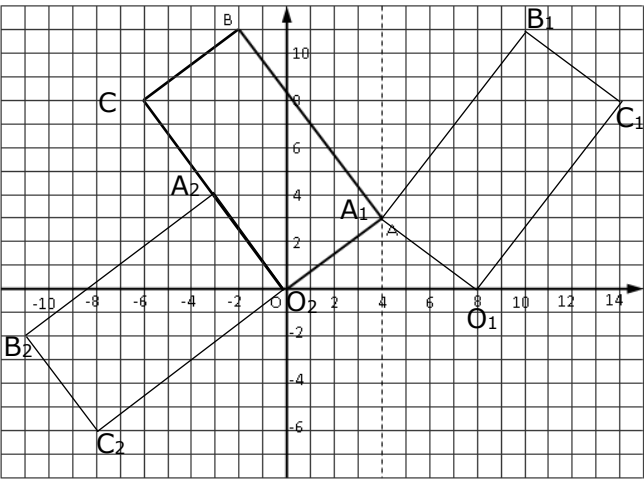
	c)	2017: $96 \div 30 = 3.2$ 2018: $122 \div 44 = 2.77$ $3.2 > 2.77$		M1 M1 A1
(Total: 6 marks)				
7.	a)	90° Angle in a semicircle		B1
	b)	$\angle ABD = 180^\circ - \angle DBC = 180^\circ - 90^\circ = 90^\circ$ (angles on a straight line) $\angle AED + \angle ABD = 90^\circ + 90^\circ = 180^\circ$ Since opposite angles are supplementary, ABDE is a cyclic Quadrilateral		M1 M1 M1
	c)	$\angle BOD = 30^\circ \times 2 = 60^\circ$ Angle at the centre is twice the angle on the circumference.		B1 B1
(Total: 6 marks)				
8.	a)		correct line BC correct $\angle B$ (45°) correct $\angle C$ (60°)	B1 B2 B1
	b)		correct perpendicular bisectors	B1 B1
	c)		correct locus: Circle correct size and position of circle	B1 B1
(total: 8 marks)				
9.	a)		Correct rectangle OABC	B1
	b)		Correct reflection Correct labels	B1 B1
	c)		Correct rotation Correct labels	B2 B2
(Total: 7 marks)				
10.	a)	$4.5 \times 2 = 9$ km		M1 A1
	b)	Total time = 4.5 hrs Av. Speed = $9.0 \div 4.5 = 2$ km/h		M1 M1 A1
	c)	30 minutes		B1
	d)	Journey back to starting position		B1

	e)	E Gradient is steepest	(Accept working out all speeds)	B1 B1
(Total: 9 marks)				
11.	a)	$5x + 20y = 235$ $x - y = 12$	Or any other equivalent equations	B1 B1
	b)	$5x + 20y = 235 \rightarrow \text{eq (1)}$ $5x - 5y = 60 \rightarrow \text{eq (2)}$ $\text{eq (1)} - \text{eq (2)} \text{ gives } 25y = 175$ $y = \frac{175}{25} = 7$ $x - 7 = 12$ $x = 19$	Multiplying by 5 Subtracting Substituting	M1 M1 M1 A1 M1 A1
(Total: 8 marks)				
12.	a)	$144 + 70 + 16 + 10 = 240$		B1
	b)	$(144 \times 1) + (70 \times 2) + (16 \times 3) + (10 \times 4)$ $= 372$		M1 A1
	c)	$372 \div 240 = 1.55$		M1 A1(ft)
	d)	$\frac{26}{240} = \frac{13}{120}$	Or equivalent	M1 A1
	e)	$P(3 \text{ or more passengers}) = \frac{13}{120} = 0.108\dot{3}$ $\text{Less than 3 passengers} = 144 + 70 = 214$ $P(\text{Less than 3 passengers}) = \frac{214}{240} = 0.891\dot{6}$ $0.891\dot{6} \neq 0.108\dot{3}$ Alex is incorrect		M1 M1 M1 M1 A1
(Total: 12 marks)				

Specimen Assessments: Controlled Paper MQF 3-3*



L-Università
ta' Malta

MATRICULATION AND SECONDARY EDUCATION CERTIFICATE
EXAMINATIONS BOARD

SECONDARY EDUCATION CERTIFICATE LEVEL SAMPLE CONTROLLED PAPER

SUBJECT: **Mathematics**
PAPER NUMBER: **Level 3 – 3***
DATE:
TIME: 2 hours

Answer **ALL** questions.

Write your answers in the space available on the examination paper.

Show clearly all the necessary steps, explanations and construction lines in your working.

Unless otherwise stated, diagrams are drawn to scale.

The use of non-programmable electronic calculators with statistical functions and mathematical instruments is allowed.

Candidates are allowed to use transparencies for drawing transformations.

This paper carries 100 marks.

Useful information:

Area of a Triangle	$\frac{1}{2} ab \sin C$
Curved Surface Area of Right Circular Cone	πrl
Surface Area of a Sphere	$4\pi r^2$
Volume of a Pyramid /Right Circular Cone	$\frac{1}{3} \text{ base area } \times \text{ perpendicular height}$
Volume of Sphere	$\frac{4}{3}\pi r^3$
Solutions of $ax^2 + bx + c = 0$	$x = \frac{-b \pm \sqrt{b^2 - 4ac}}{2a}$
Sine formula	$\frac{a}{\sin A} = \frac{b}{\sin B} = \frac{c}{\sin C}$
Cosine formula	$a^2 = b^2 + c^2 - 2bc \cos A$
Compound Interest / Appreciation & Depreciation	$A = P \left(1 \pm \frac{r}{100}\right)^n$

- 1) EDOC is a straight line. DC is a diameter to the circle centre O. The line ABC is the hypotenuse of the right-angled triangle AEC.

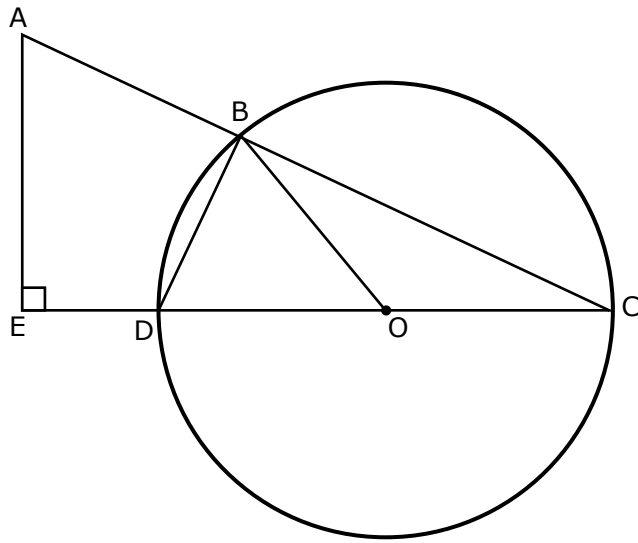

Diagram not drawn to scale

- a) Show that ABDE is a cyclic quadrilateral.

(3)

- b) Angle $\text{ACE} = 30^\circ$. Find the size of angle BOD. Give a reason for your answer.

(2)

(Total: 5 marks)

2) In this question, use ruler and compasses only.

- a) Construct a triangle ABC in the space below such that $BC = 10$ cm, angle $ABC = 45^\circ$ and angle $ACB = 60^\circ$.

(4)

- b) Construct the perpendicular bisectors of lines AB and BC. Label the point O where these two perpendicular bisectors meet.

(2)

- c) Draw the locus of the point which is 5.2 cm from O.

(1)

(Total: 7 marks)

3)

- a) In a supermarket, the price of a 0.75 litre bottle of sparkling water was €0.55. It is now being sold in a six-pack of 1 litre bottles at €5.28 per pack.

- i. Calculate the percentage increase in the cost per litre of sparkling water.

(4)

- ii. The supermarket sold 203 six-packs of 1 litre bottles and made 12% profit. How much did these bottles cost to the supermarket?

(4)

- b) In the first 5 years, the price of a new luxury car will decrease by 10% each year. The price will then decrease by 8% each year. How much will the car cost in 7 years' time if the price of a new car today is €72 000?

(4)

(Total: 12 marks)

4)

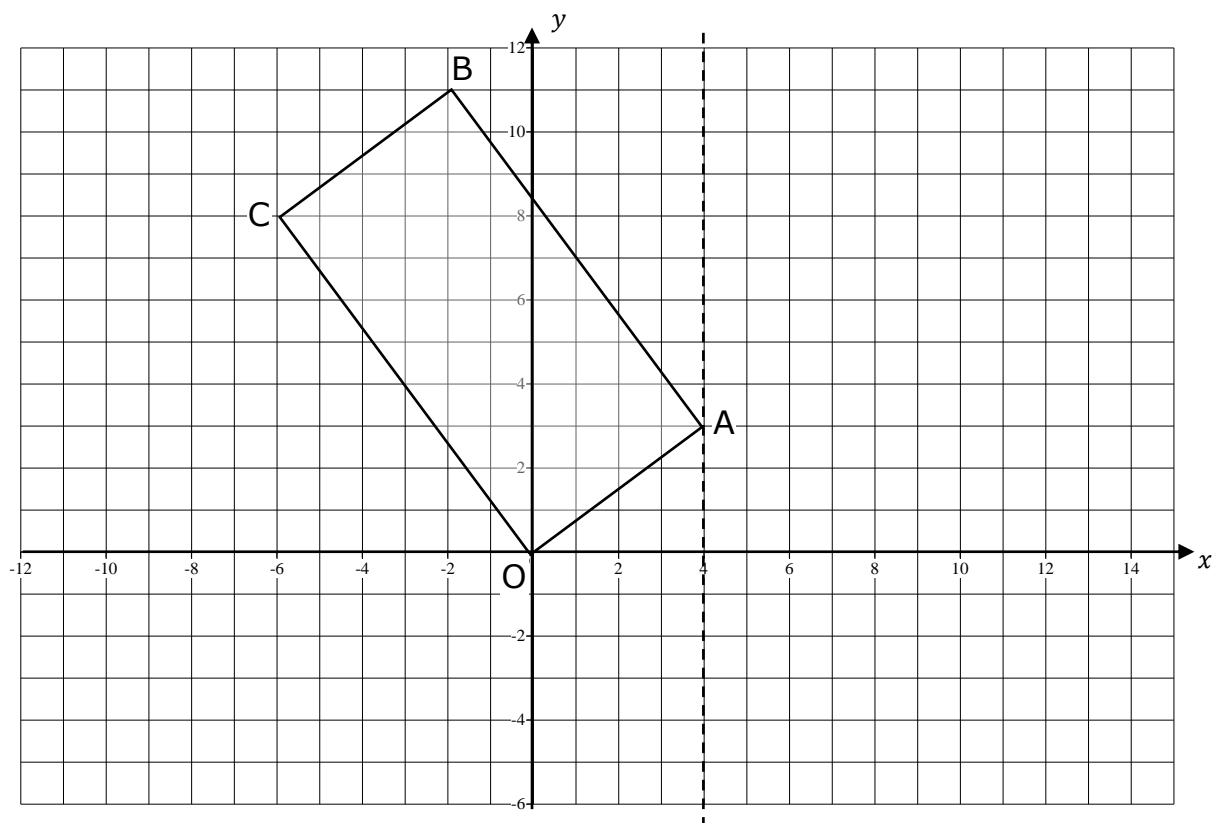

- a) Draw and label the reflection of OABC in the line $x = 4$, to form rectangle $O_1A_1B_1C_1$.

(2)

- b) Rotate rectangle OABC 90° anticlockwise about the origin to form $OA_2B_2C_2$. Draw and label rectangle $OA_2B_2C_2$.

(4)

(Total: 6 marks)

5)

- a) Solve each of the following **TWO** inequalities [P] and [Q].

$$[P] \quad 2x + 1 < 7$$

$$[Q] \quad 1 - 5x \leq x + 4$$

(4)

- b) Show the solutions of the two inequalities [P] and [Q] on the same number line below.

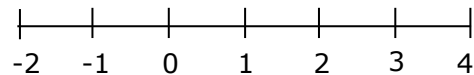

(2)

- c) Write down the largest integer that satisfies both the inequalities [P] and [Q].

(1)

(Total: 7 marks)

6)

- a) Solve the following equation giving your answers correct to 2 decimal places:

$$2x^2 + 5x - 1 = 0$$

(4)

- b) Solve the equation: $\frac{6}{2x-1} - \frac{3}{x+1} = 1$.

(4)

(Total: 8 marks)

7) The stacked bar chart below shows the staff employed by a firm in the years 2016, 2017 and 2018.

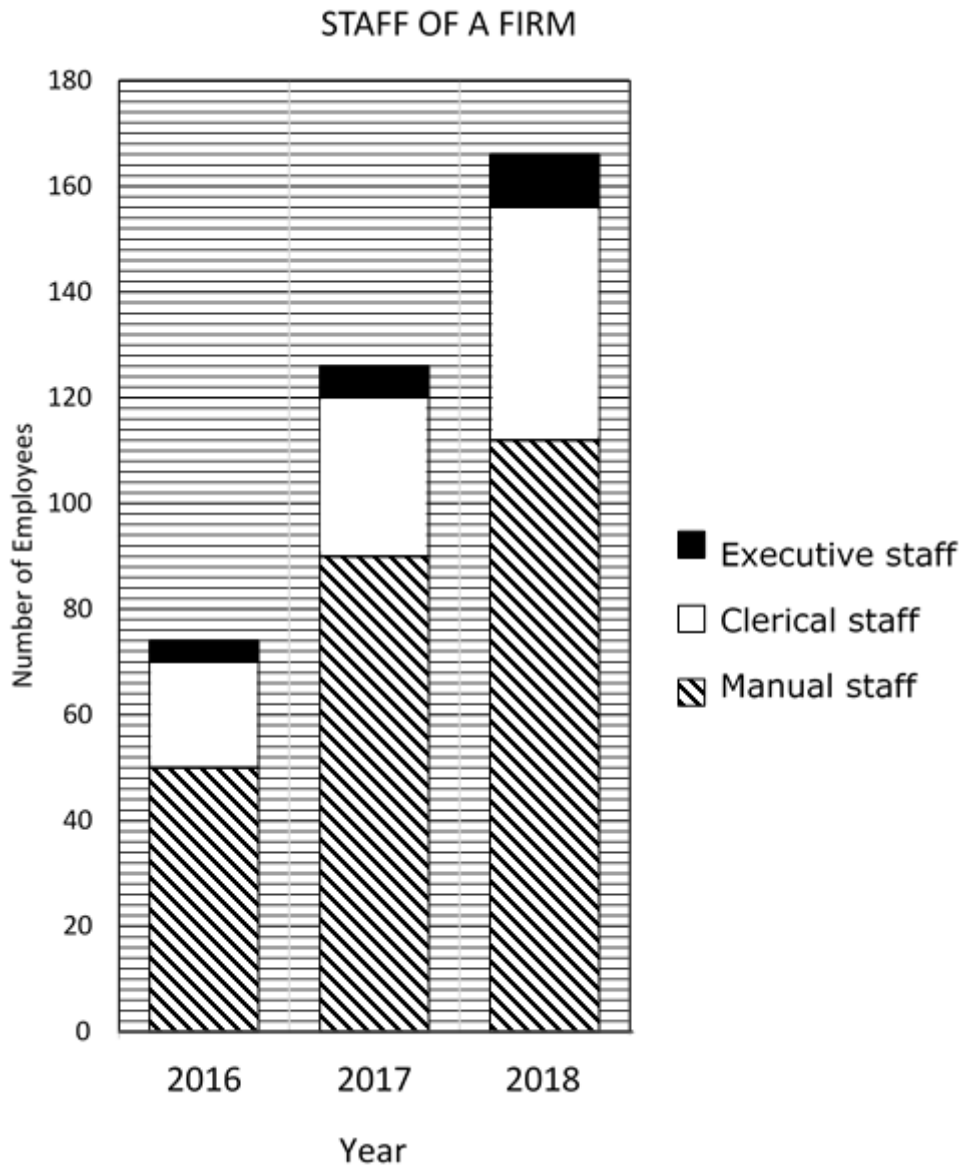

a) What fraction of the total staff in 2016 consisted of Clerical staff?

(2)

b) A report in the company magazine stated that, for each clerk, there were more Manual and Executive workers in 2017, than there were in 2018. Show that this report is correct.

(3)

(Total: 5 marks)

8) When it does not rain, the probability that Nathan goes fishing is $\frac{6}{7}$. When it does rain, the probability that Nathan goes fishing is $\frac{1}{5}$. The chance that it will rain tomorrow is 30%.

a) Complete the tree diagram writing the probabilities on the branches.

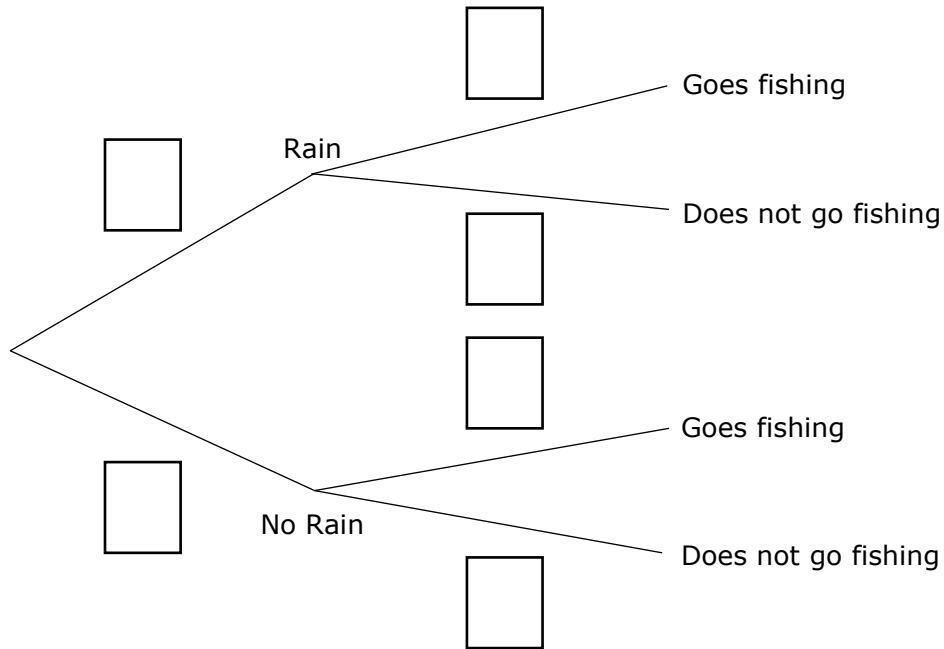

(2)

b) Calculate the probability that tomorrow, Nathan will not go fishing.

(5)

c) Last year Nathan went fishing 22 times and on 3 occasions he caught more than 2 kg of fish. What is the probability that tomorrow, Nathan will catch more than 2 kg of fish?

(3)

(Total: 10 marks)

9)

a)

i. Use prime factors to find Highest Common Factor of 128 and 72.

(4)

ii. Factorise completely the expression: $128yx^2 - 72y$.

(2)

b) Solve the equation: $25^{2x} = 125^{(x+3)}$.

(3)

(Total: 9 marks)

10) Traffic police use two speed cameras, set up at two points, A and B on a main road, 0.5 km apart (correct to 1 d.p.). The speed limit is 70 km/h. Malcolm takes 25 seconds (correct to the nearest second) to drive from point A to point B and he is fined for over speeding.

a) Write down the lower and the upper bound of the distance AB and of the time taken by Malcolm to cover this distance.

(2)

b) Malcolm says that he was travelling under the speed limit. Show how Malcolm could be right.

(3)

(Total: 5 marks)

11) a) Neglecting air resistance, the distance (d) covered by a falling object is directly proportional to the square of the time (t) it has been falling. If an object falls 19.56 m in 2 seconds, determine the distance it will fall in 6 seconds.

(4)

- b) The full capacity of a cone is 2.5 litres. The cone is filled with water exactly half way up. Calculate the volume of the empty space in the cone.

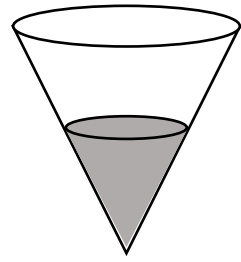

(4)

(Total: 8 marks)

- 12) A sphere is cut in half to form two identical hemispheres. The total surface area of the two hemispheres together is 192 cm^2 .

- a) Show that the surface area of the sphere is 128 cm^2 .

(3)

- b) Points A, B and C form a triangle on a plane where $AC = 125 \text{ m}$, $BC = 320 \text{ m}$ and $AB = 431 \text{ m}$. B is on a bearing of 083° from C.

- i. Calculate the size of angle ACB.

Diagram not drawn to scale

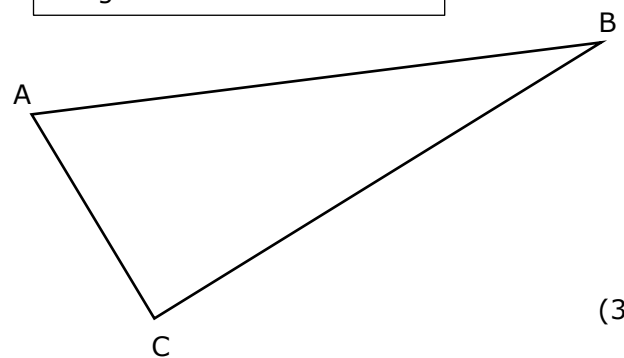

(3)

- ii. Calculate the bearing of A from C.

(1)

(Total: 7 marks)

13)

a) Complete the table of the graph $y = 2x^2 - 5x$.

x	-0.5	0	0.5	1	1.5	2	2.5	3
y								

(3)

b) Draw the graph of $y = 2x^2 - 5x$ on the grid below.

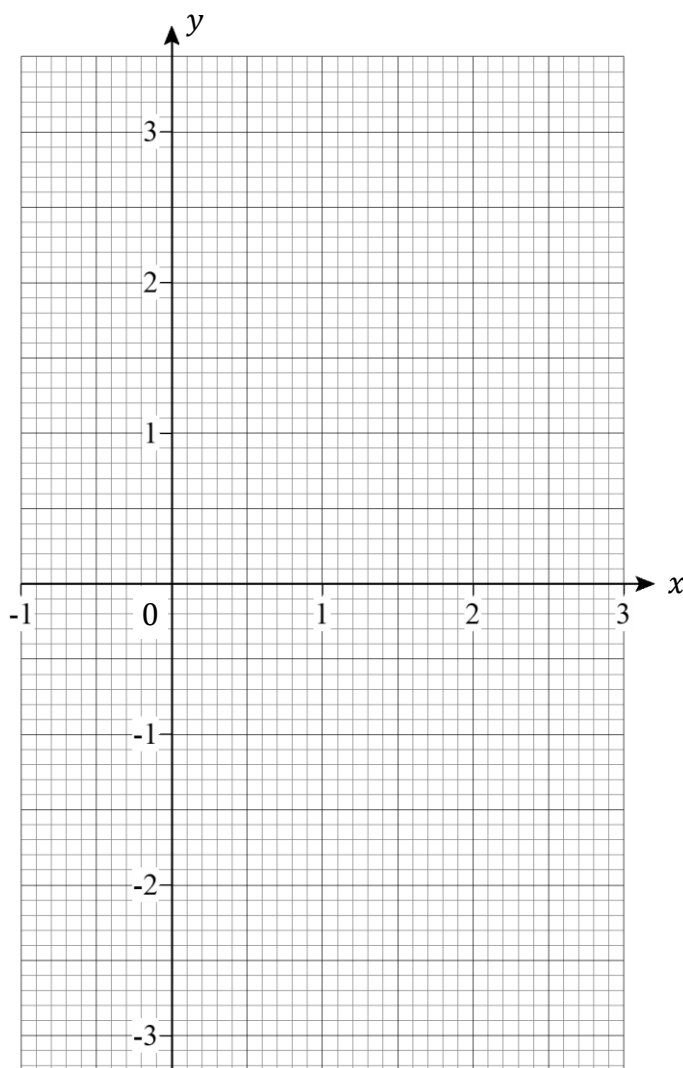

(2)

c) On the same grid above draw a suitable straight-line graph and use both graphs to solve the equation: $x^2 - 3x + 1 = 0$.

(6)

(Total: 11 marks)

END OF PAPER



L-Università
ta' Malta

MATRICULATION AND SECONDARY EDUCATION CERTIFICATE
EXAMINATIONS BOARD

**SECONDARY EDUCATION CERTIFICATE LEVEL
MARKING SCHEME FOR SAMPLE CONTROLLED PAPER**

SUBJECT: **Mathematics**
PAPER NUMBER: **Level 3 – 3***
DATE:
TIME: 2 hours

Question No.	Workings and Solutions	Additional guidance	Marks
1)	a) $\angle DBC = 90^\circ$ (angle in a semicircle) $\angle ABD = 180^\circ - 90^\circ = 90^\circ$ (angles on a straight line) $\angle AED + \angle ABD = 90^\circ + 90^\circ = 180^\circ$ Since opposite angles are supplementary, ABDE is a cyclic Quadrilateral		B1 M1 M1
	b) $\angle BOD = 30^\circ \times 2 = 60^\circ$ Angle at the centre is twice the angle on the circumference.		B1 B1
(Total: 5 marks)			
2)		correct line BC	B1
		correct $\angle B$ (45°)	B1
		correct $\angle C$ (60°)	B1
b)	correct perpendicular bisectors	B1 B1	
c)	correct locus: Circle	B1	
	correct radius and position of circle	B1	
(Total: 7 marks)			

3)	a)	i. $0.55 \div 0.75 = 0.7\bar{3}$ $5.28 \div 6 = 0.88$ $\% \text{ increase} = \frac{0.88 - 0.7\bar{3}}{0.7\bar{3}} \times 100 = 20$ ii. $100\% + 12\% = 112\% = 1.12$ $203 \times 5.28 \div 1.12 = \text{€ } 957$		M1 M1 M1 A1 (f.t.) M1 A1 M1 A1
	b)	$100\% - 10\% = 90\% = 0.9$ and $100\% - 8\% = 92\% = 0.92$ $72\,000 \times 0.9^5 \times 0.92^2 = \text{€ } 35\,985$	Both correct M1 for correct use of power. M1 for multiplying.	M1 M1 M1 A1

(Total: 12 marks)

4)	a)		Correct reflection	B1
	b)		Correct labels (all correct) Correct rotation Correct labels (1 mark for each two correct labels)	B1 B2 B2

(Total: 6 marks)

5)	a)	[P] $2x < 6$ $x < 3$ [Q] $-3 \leq 6x$ $-\frac{1}{2} \leq x$		M1 A1 M1 A1
	b)		Correct arrows and endpoints	B1 B1
	c)	2		B1

(Total: 7 marks)

6)	a)	$x = \frac{-5 \pm \sqrt{5^2 - 4 \times 2 \times (-1)}}{2 \times 2}$		M1
		$x = \frac{-5 \pm \sqrt{33}}{4}$		M1
		$x = 0.19 \text{ and } -2.69$	1 mark for each correct value	A2

	b)	$6(x + 1) - 3(2x - 1) = (2x - 1)(x + 1)$ $6x + 6 - 6x + 3 = 2x^2 + 2x - x - 1$ $2x^2 + x - 10 = 0$ $(2x + 5)(x - 2) = 0$ $x = -\frac{5}{2} \text{ or } 2$	Removing denominators Simplifying and equating to zero Factorising Both values correct	M1 M1 M1 A1
(Total: 8 marks)				
7)	a)	20 clerks out of 74 $\frac{10}{37}$		M1 A1
	b)	2017: $96 \div 30 = 3.2$ 2018: $122 \div 44 = 2.77$ $3.2 > 2.77$		M1 M1 A1
(Total: 5 marks)				
8)	a)		Correct first branch Correct second branch	B1 B1
	b)	$\frac{3}{10} \times \frac{4}{5} = \frac{6}{25}$ $\frac{7}{10} \times \frac{1}{7} = \frac{1}{10}$ $\frac{6}{25} + \frac{1}{10} = \frac{17}{50}$		B1 B1 M1 M1A1(f.t)
	c)	$1 - \frac{17}{50} = \frac{33}{50}$ $\frac{3}{22} \times \frac{33}{50} = \frac{9}{100}$		M1 M1A1(f.t)
(Total: 10 marks)				

9)	a)	i. $128 = 2^7$ $72 = 2^3 \times 3^2$ $\text{HCF} = 2^3 = 8$ ii. $8y(16x^2 - 9)$ $8y(4x - 3)(4x + 3)$		M1 M1 M1 A1 M1 A1
	b)	$(5^2)^{2x} = (5)^{3(x+3)}$ $4x = 3(x + 3)$ $4x = 3x + 9$ $x = 9$		M1 M1 A1
(Total: 9 marks)				
10)	a)	i. $0.45 \leq \text{distance} \leq 0.55$ $24.5 \leq \text{time} \leq 25.5$	Both values correct Both values correct	B1 B1
	b)	$\text{Time}_{(\text{upper bound})} \text{ in hours} = 25.5 \div 60 \div 60$ $\text{Speed}_{(\text{lower bound})} = \frac{\text{Distance}_{(\text{lower bound})}}{\text{Time}_{(\text{upper bound})}}$ $\text{Speed}_{(\text{lower bound})} = \frac{0.45}{25.5 \div 60 \div 60} = 63.5 \text{ km/h}$		M1 M1 A1 (f.t.)
(Total: 5 marks)				
11)	a)	$d = kt^2$ $19.56 = k(2)^2 \Rightarrow k = 19.56 \div 4 = 4.89$ $d = 4.89t^2 = 4.89 \times 6^2 = 176.04 \text{ m}$		M1 M1 M1 A1
	b)	Volume scale factor = $2^3 = 8$ Volume of small cone = $2.5 \div 8 = 0.3125 \text{ l}$ Volume of frustum = $2.5 - 0.3125 = 2.1875 \text{ l}$	Accept 2.2 l or more accurate	M1 M1 M1 A1
(Total: 8 marks)				
12)	a)	$2 \times (\text{S.A.}) = 2 \times (2\pi r^2 + \pi r^2)$ $192 = 6\pi r^2 = 192$ $\Rightarrow \pi r^2 = 32$ Surface area of sphere = $4\pi r^2 = 128 \text{ cm}^2$	Formulating	M1 M1 A1
	ii)	i. $\text{Cos } \hat{A}CB = \frac{a^2 + b^2 - c^2}{2ab}$ $\text{Cos } \hat{A}CB = \frac{320^2 + 125^2 - 431^2}{2 \times 125 \times 320} = -0.8467$ $\hat{A}CB = \cos^{-1} - 0.8467$ $= 148^\circ$ ii. $360^\circ - (148^\circ - 83^\circ) = 295^\circ$		M1 M1 A1 B1
(Total: 7 marks)				

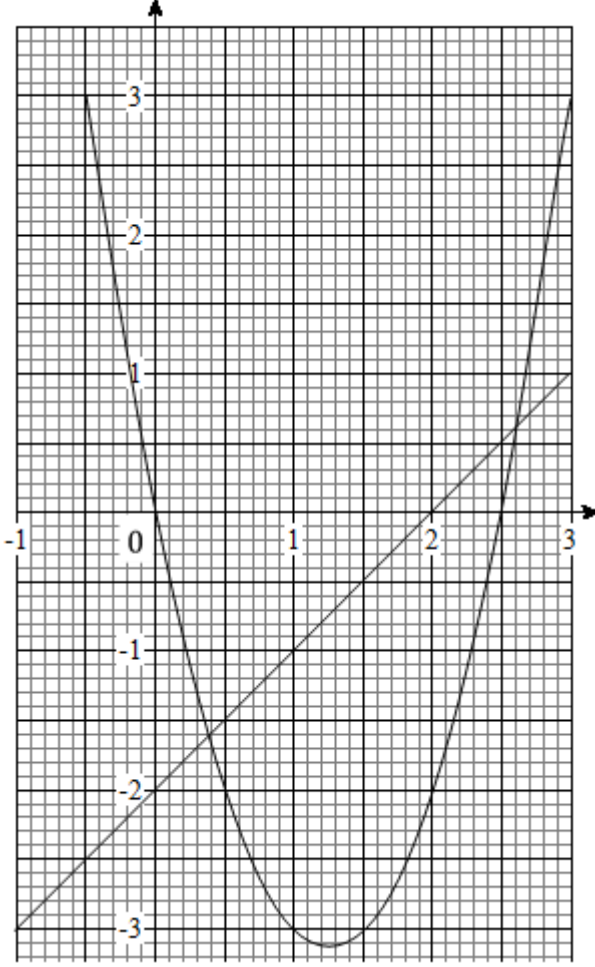
13)	a)	<table border="1" style="margin-left: auto; margin-right: auto;"> <tr> <td style="padding: 2px;">x</td> <td style="padding: 2px;">-0.5</td> <td style="padding: 2px;">0</td> <td style="padding: 2px;">0.5</td> <td style="padding: 2px;">1</td> <td style="padding: 2px;">1.5</td> <td style="padding: 2px;">2</td> <td style="padding: 2px;">2.5</td> <td style="padding: 2px;">3</td> </tr> <tr> <td style="padding: 2px;">y</td> <td style="padding: 2px;">3</td> <td style="padding: 2px;">0</td> <td style="padding: 2px;">-2</td> <td style="padding: 2px;">-3</td> <td style="padding: 2px;">-3</td> <td style="padding: 2px;">-2</td> <td style="padding: 2px;">0</td> <td style="padding: 2px;">3</td> </tr> </table>	x	-0.5	0	0.5	1	1.5	2	2.5	3	y	3	0	-2	-3	-3	-2	0	3	-1 e.e.o.o.	B3
x	-0.5	0	0.5	1	1.5	2	2.5	3														
y	3	0	-2	-3	-3	-2	0	3														
			<p>Correct plotting B1</p> <p>Correct curve B1</p>																			
b)		$2(x^2 - 3x + 1) = 0$ $2x^2 - 6x + 2 = 0$ $2x^2 - 6x + 2 + x - 2 = x - 2$ $2x^2 - 5x = x - 2$ $y = x - 2$ $x = 2.6 \text{ and } 0.4$	<p>Multiplying by 2 M1</p> <p>Adding $x - 2$ on both sides of equation. M1</p> <p>Simplifying. Finding equation of straight line. M1</p> <p>Drawing of straight line. M1</p> <p>x values of points of intersection. ± 0.1 B1 B1</p>																			
(Total: 11 marks)																						

Specimen Assessments: Private Candidates Controlled Paper MQF 1-2-3



L-Università
ta' Malta

MATRICULATION AND SECONDARY EDUCATION CERTIFICATE
EXAMINATIONS BOARD

SECONDARY EDUCATION CERTIFICATE LEVEL SAMPLE PRIVATE CANDIDATES CONTROLLED PAPER

SUBJECT: **Mathematics**
PAPER NUMBER: **Level 1 – 2 - 3**
DATE:
TIME: 2 hours

Answer **ALL** questions.

Write your answers in the space available on the examination paper.

Show clearly all the necessary steps, explanations and construction lines in your working.

Unless otherwise stated, diagrams are drawn to scale.

The use of non-programmable electronic calculators with statistical functions and mathematical instruments is allowed.

Candidates are allowed to use transparencies for drawing transformations.

This paper carries 100 marks.

1. a) Complete the pattern to make it symmetrical about the dotted line.

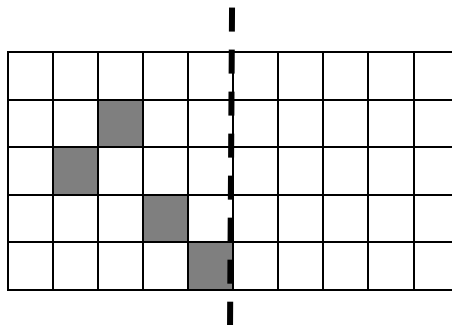

(2)

b) Complete the shape to make it symmetrical about the two dotted lines.

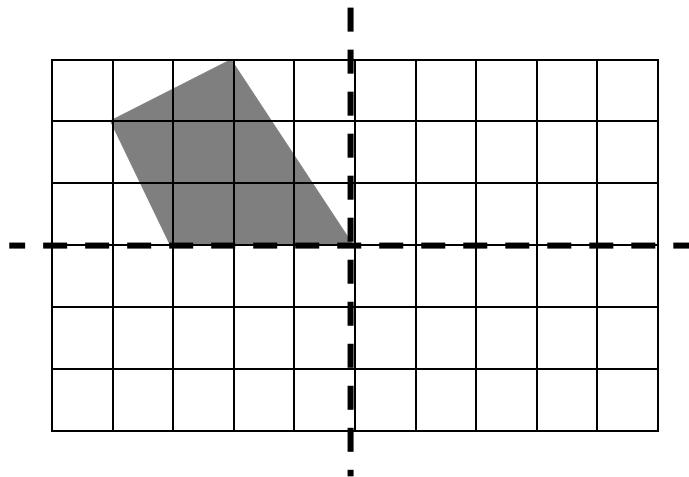

(3)

c)

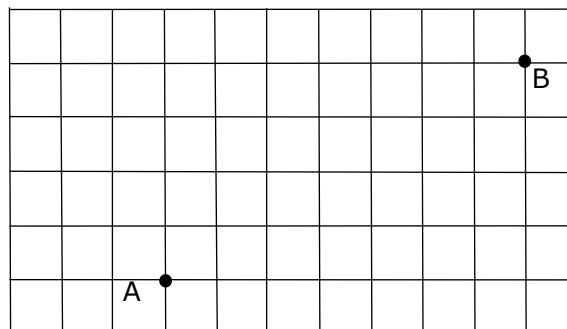

i. Move point A: 5 right and 2 up.

Label it A_1 .

ii. Move point B: 9 left and 3 down.

Label it B_2 .

(2)

(Total: 7 marks)

2. 271 school children and 11 teachers are going on a school trip. Coaches can carry a maximum of 51 passengers and minivans can carry a maximum of 14 passengers.

a) How many coaches can be completely filled with these passengers?

(2)

b) How many more minivans are needed for the remaining passengers?

(3)

(Total: 5 marks)

3. A teacher asked her pupils to create 5-digit numbers using all the cards below.



Use all the cards to write:

a) The largest possible 5-digit odd number:

--	--	--	--	--

b) The largest possible 5-digit even number:

--	--	--	--	--

c) The smallest possible 5-digit odd number:

--	--	--	--	--

d) The smallest possible 5-digit even number:

--	--	--	--	--

(Total: 4 marks)

4. Ryan, Stephanie, Mark and Lisa go to different schools. They carried out a survey to find the average number of books carried to school by their school mates. The tables below show the data they collected from their schools.

Ryan:

Number of books	1	2	3	4	5	Total
Tally	HHH HHH I	HHH HHH HHH HHH I	HHH HHH I	HHH	III	
Frequency	11			5		

Stephanie:

Number of books	1	2	3	4	5	Total
Tally	HHH III	HHH HHH HHH HHH II	HHH HHH	HHH	I	
Frequency		22				

Mark:

Number of books	1	2	3	4	5	Total
Tally	HHH HHH III	HHH HHH HHH II	HHH III	HHH II	II	47
Frequency						

Lisa:

Number of books	1	2	3	4	5	Total
Tally	HHH I	HHH HHH HHH II	HHH HHH I	HHH	II	
Frequency	6	12			2	

- a) Complete the tables above. (4)
- b) Complete the following table showing the total frequency from the four schools. Hence, calculate the angles to be represented on a pie-chart.

Number of books	1	2	3	4	5	Total
Total Frequency	38					180
Angle on Pie Chart	76°					360°

(2)

c) Draw a pie chart in the space below, using the angles found in part (b), to illustrate the data.

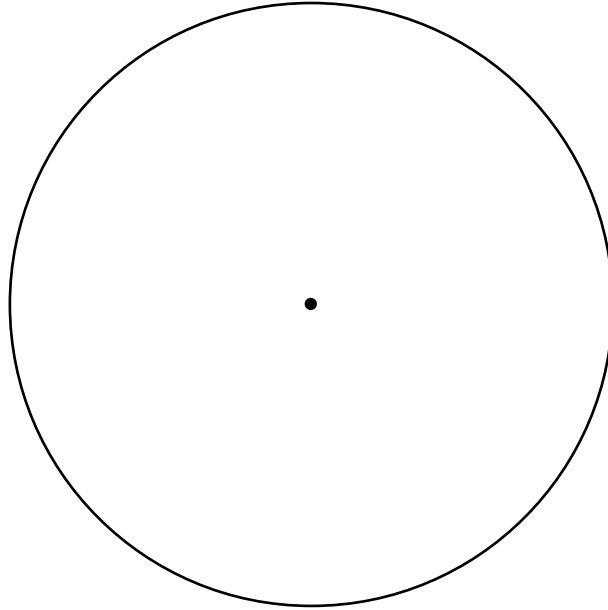

(3)

(Total: 9 marks)

5. a) Express **162** as a product of prime factors.
Give your answer in standard index form.

(2)

b) State the least multiple by which 162 should be multiplied in order to change it to a perfect square.

(1)

(Total: 3 marks)

6. Lara uses footsteps to calculate the length and breadth of this rectangular yard. The length of one footstep is 24cm.



<https://www.mypatiodesign.com/products/>

- a) She counts 18 footsteps to walk along the length. Calculate the length in metres.

(2)

- b) She counts 15 footsteps to walk along the width. Calculate the width in metres.

(2)

- c) Hence, find the area in m^2 of this rectangular space.

(2)

- d) The rectangular space is covered with square tiles of side 15cm. Calculate how many tiles are needed to cover the rectangular space. Give your answer to the nearest whole number.

(4)

(Total: 10 marks)

7. Amy wants to find the height of a tree in the garden. She moves away from the tree and looks at its top, as shown in the diagram.

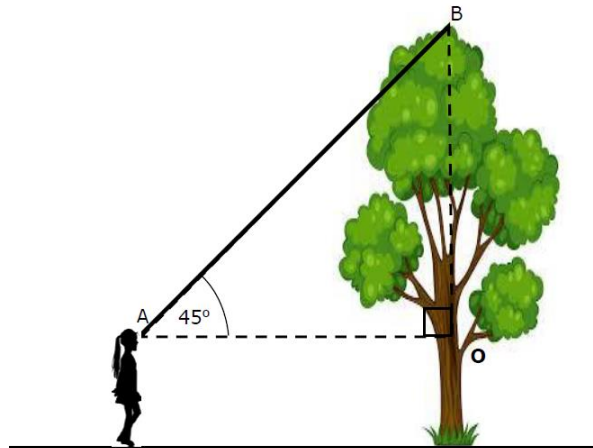

- a) What is the size of angle ABO?

(1)

- b) What kind of triangle is $\triangle ABO$?

(1)

- c) How tall do you think Amy is? (*Circle the right answer*)

0.16m 1.6m 1600cm

(1)

- d) Amy's friend measures the distance between Amy and the tree and finds that it is 2.38m. Calculate the height of the tree.

(2)

(Total: 5 marks)

8. Maria found this entryway in a garden. She drew the shape of the entryway on her copybook as shown in the following line drawing.

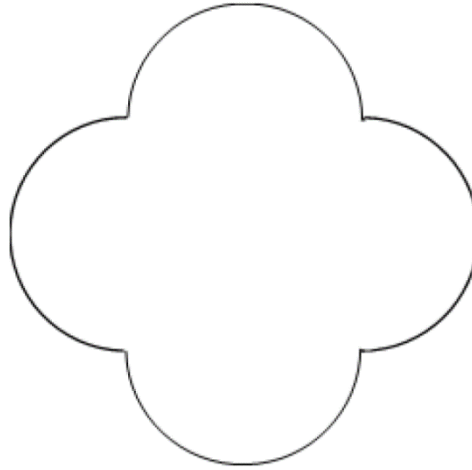

- a) Draw all the lines of symmetry on the shape in the line drawing above. (2)
- b) How many full circles make up the perimeter of this shape? _____ (1)
- c) Maria measures the length ***d*** and finds that it is 1.05m long. Find the perimeter of the shape.

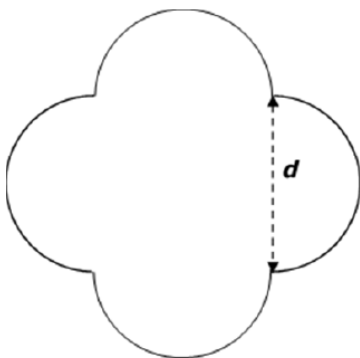

(3)

(Total: 6 marks)

9. Brian is using an application which simulates an 8-sector spinner. The following is a screen shot of the results after 50 spins.

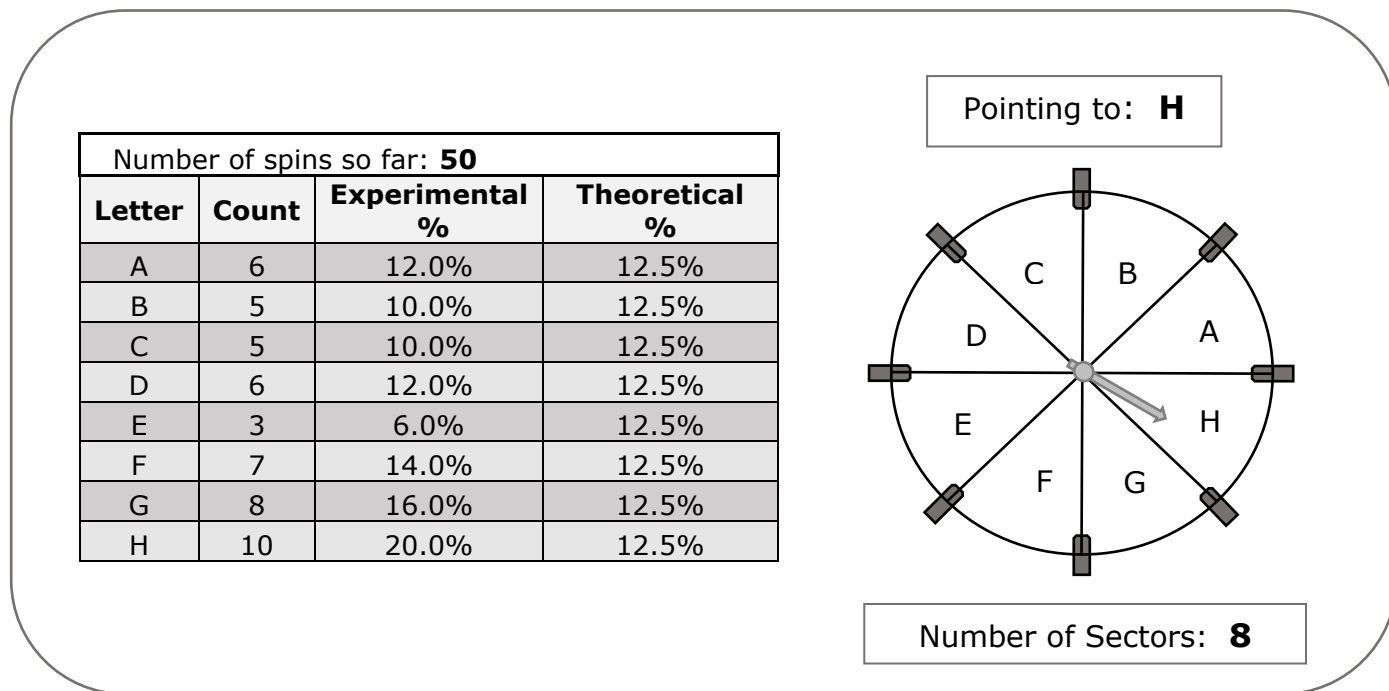

- a) Explain why the theoretical probability for **all** the colours is the same. (1)
- b) Give **ONE** reason why the experimental probabilities are **not** equal to the theoretical probabilities. (1)
- c) What is the theoretical probability that the spinner stops on either B or D? (2)
- d) What is the experimental probability that the spinner stops on either B or D? (1)
- e) Would you say that the application is fair or biased? Give a reason for your answer. (1)
- f) What should Brian do so that he can check whether the application is fair or not? (1)

(Total: 7 marks)

10. a) Complete the following table for $y = 2x - 1$.

x	-1	0	1	2	3
y					

(2)

b) Draw the graph of $y = 2x - 1$.

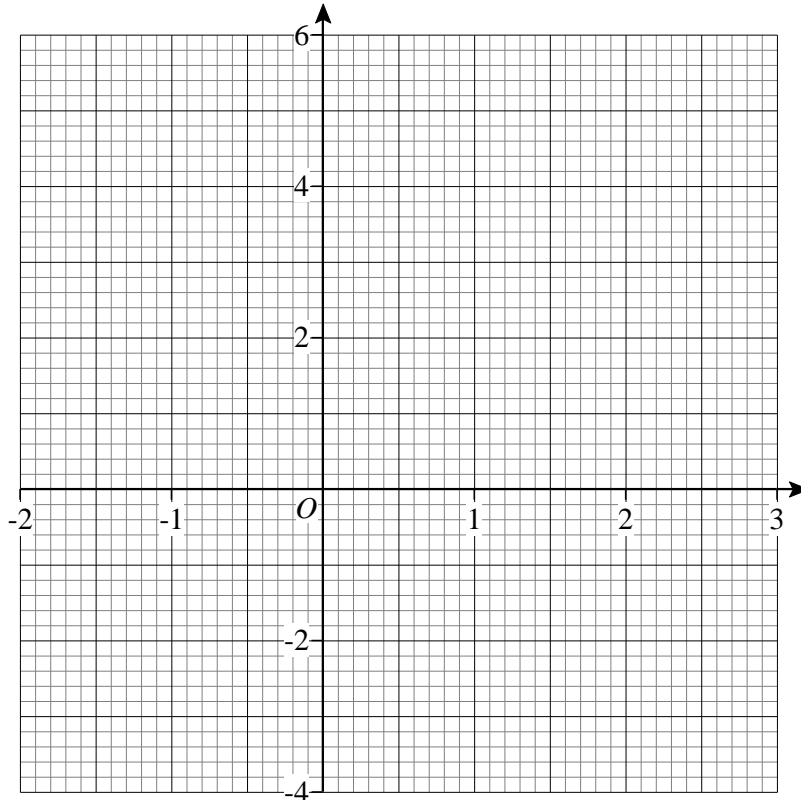

(2)

c) Draw a second straight line graph that passes through the two points $(-1, 5)$ and $(2, -4)$.

(1)

d) Write down the **equation** of the straight line described in part (c).

(3)

e) Hence, solve the following pair of simultaneous equations graphically.

$y = 2x - 1$ $y = -3x + 2$

(2)

(Total: 10 marks)

11. The diagram shows two rectangles.

The width and height of rectangle B are both **20% greater than** the width and height of rectangle A.

Use the figures given to find the width and height of rectangle A.

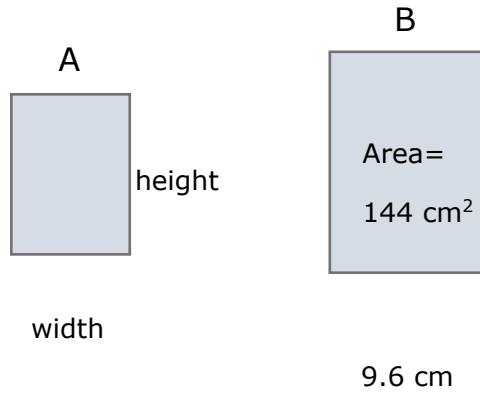

(Total: 5 marks)

12. Paul was asked to find the sum of the terms from the 23rd up to and including the 124th term of a linear sequence that starts as follows:

8, 11, 14, 17, ...

The n^{th} term of this sequence is: $3n+5$.

a) Find the 23rd term and the 124th term of this sequence.

(4)

b) Find how many terms there are from the 23rd up to and including the 124th term.

(2)

c) Paul noticed something about the following totals. What did Paul notice?

$$23^{\text{rd}} \text{ term} + 124^{\text{th}} \text{ term},$$

$$24^{\text{th}} \text{ term} + 123^{\text{rd}} \text{ term},$$

$$25^{\text{th}} \text{ term} + 122^{\text{nd}} \text{ term}, \dots$$

(3)

d) Hence or otherwise, work out the sum of **all** the terms from the 23rd up to and including the 124th term.

(4)

(Total: 13 marks)

13. Using a ruler and compasses only:

a) Construct triangle ABC such that $BC = 10 \text{ cm}$, $\hat{A}BC = 45^\circ$ and angle $\hat{A}CB = 60^\circ$.

(4)

b) Construct the perpendicular bisectors of lines AB and BC.

Label the point O where these two perpendicular bisectors meet.

(2)

c) Draw the locus of the point which is 5.2 cm from O.

(2)

(Total: 8 marks)

14. The distance - time graph shows the journey of man who went for a walk.

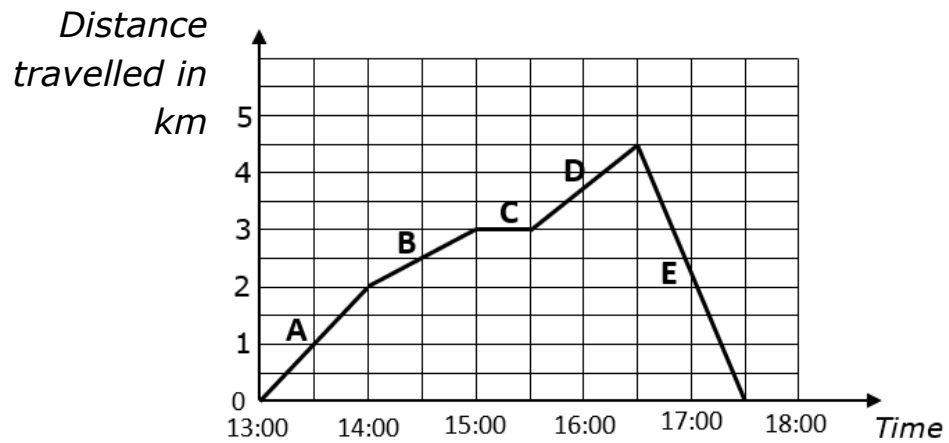

a) How far did he travel altogether?

(2)

b) Calculate his average speed in km/h.

(3)

c) For how long did he stop?

(1)

d) In which stage, A, B, C, D, or E, did he travel fastest?
Give a reason for your answer.

(2)

(Total: 8 marks)

END OF PAPER



**SECONDARY EDUCATION CERTIFICATE LEVEL
MARKING SCHEME FOR SAMPLE PRIVATE CANDIDATES
CONTROLLED PAPER**

SUBJECT: **Mathematics**
 PAPER NUMBER: **Level 1 – 2 – 3**
 DATE:
 TIME: 2 hours

Que.		Marks	Additional Guidance
1.	a)	B2	7 1 mark each for two correct squares
	b)	B3	
	c)	B1 B1	
2.	a)	M1 A1	5 1 mark for each two correct digits
	b)	M1 M1 A1	
3.	a)	B1	4
	b)	B1	
	c)	B1	
	d)	B1	

4.	a)	<p>Ryan:</p> <table border="1"> <tr><td>No.</td><td>1</td><td>2</td><td>3</td><td>4</td><td>5</td><td>Total</td></tr> <tr><td>Freq.</td><td>11</td><td>21</td><td>11</td><td>5</td><td>3</td><td>51</td></tr> </table> <p>Stephanie:</p> <table border="1"> <tr><td>No.</td><td>1</td><td>2</td><td>3</td><td>4</td><td>5</td><td>Total</td></tr> <tr><td>Freq.</td><td>8</td><td>22</td><td>10</td><td>5</td><td>1</td><td>46</td></tr> </table> <p>Mark</p> <table border="1"> <tr><td>No.</td><td>1</td><td>2</td><td>3</td><td>4</td><td>5</td><td>Total</td></tr> <tr><td>Freq.</td><td>13</td><td>17</td><td>8</td><td>7</td><td>2</td><td>47</td></tr> </table> <p>Lisa</p> <table border="1"> <tr><td>No.</td><td>1</td><td>2</td><td>3</td><td>4</td><td>5</td><td>Total</td></tr> <tr><td>Freq.</td><td>6</td><td>12</td><td>11</td><td>5</td><td>2</td><td>36</td></tr> </table>	No.	1	2	3	4	5	Total	Freq.	11	21	11	5	3	51	No.	1	2	3	4	5	Total	Freq.	8	22	10	5	1	46	No.	1	2	3	4	5	Total	Freq.	13	17	8	7	2	47	No.	1	2	3	4	5	Total	Freq.	6	12	11	5	2	36	B1 B1 B1 B1	9	
	No.	1	2	3	4	5	Total																																																						
	Freq.	11	21	11	5	3	51																																																						
	No.	1	2	3	4	5	Total																																																						
Freq.	8	22	10	5	1	46																																																							
No.	1	2	3	4	5	Total																																																							
Freq.	13	17	8	7	2	47																																																							
No.	1	2	3	4	5	Total																																																							
Freq.	6	12	11	5	2	36																																																							
b)	<table border="1"> <tr><td>No.</td><td>1</td><td>2</td><td>3</td><td>4</td><td>5</td><td>Total</td></tr> <tr><td>Freq.</td><td>38</td><td>72</td><td>40</td><td>22</td><td>8</td><td>180</td></tr> <tr><td>Angle</td><td>76°</td><td>144°</td><td>80°</td><td>44°</td><td>16°</td><td>360°</td></tr> </table>	No.	1	2	3	4	5	Total	Freq.	38	72	40	22	8	180	Angle	76°	144°	80°	44°	16°	360°	B1 B1																																						
No.	1	2	3	4	5	Total																																																							
Freq.	38	72	40	22	8	180																																																							
Angle	76°	144°	80°	44°	16°	360°																																																							
c)	Correct pie chart drawn	B3																																																											
5.	a)	$\begin{array}{r} 2 \overline{)162} \\ \underline{3 \ 18 \ 1} \\ 3 \overline{)27} \\ \underline{3 \ 19} \\ 3 \overline{)33} \\ \underline{\quad 1} \end{array}$ <p>Ans. 2×3^4</p>	M1 A1	3																																																									
	b)	2	B1																																																										
6.	a)	Length = $18 \times 24 = 432\text{cm}$ = 4.32 m	M1 A1	10																																																									
	b)	Width = $15 \times 24 = 360\text{cm}$ = 3.6 m	M1 A1																																																										
	c)	Area = 4.32×3.6 = 15.552m^2	M1 A1 f.t.																																																										
	d)	Area of 1 tile = 0.15×0.15 = 0.0225m^2 Number of tiles = $15.552 \div 0.0225$ = 691 tiles	M1 A1 M1 A1 f.t.																																																										
7.	a)	45°	B1	5																																																									
	b)	Isosceles or right-angled triangle	B1																																																										
	c)	1.6m	B1																																																										
	d)	Height = $1.6\text{m} + 2.38\text{m}$ = 3.98m	M1 A1 f.t.																																																										

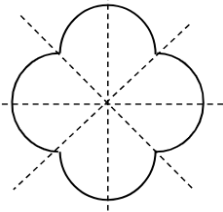
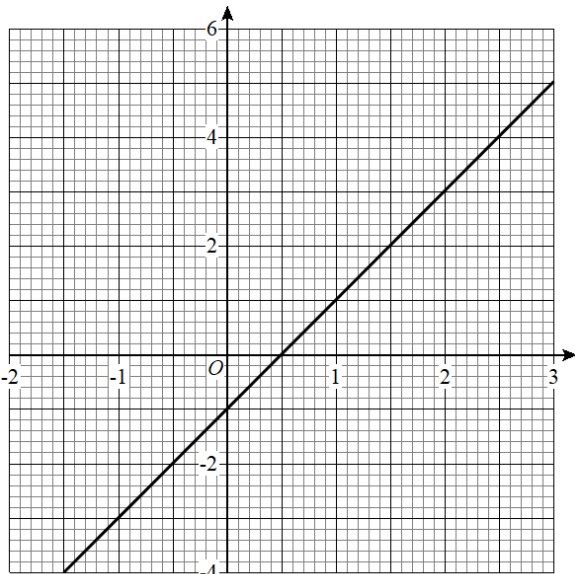
8.	a)		B2	6													
	b)	2	B1														
	c)	Circumference = πd Perimeter = $2 \times \pi \times 1.05 = 6.6 \text{ m}$	M1 M1A1														
9.	a)	Angle at the centre of all sectors is the same.	B1	7	Or any other valid reason												
	b)	Theoretical probability is what one expects to happen, but it isn't always what actually happens during an experiment.	B1														
	c)	$12.5 \times 2 = 25\%$	M1A1														
	d)	$10 + 12 = 22\%$	B1														
	e)	Fair because for most of the outcomes, the experimental probability is very close to the theoretical probability or Biased because there are two outcomes where there is a big difference between the experimental and the theoretical probability.	B1		Or any other valid reason												
	f)	Increase the number of spins.	B1		Or any other valid reason												
10.	a)	<table border="1" data-bbox="331 1142 925 1299"> <tbody> <tr> <td>x</td> <td>-1</td> <td>0</td> <td>1</td> <td>2</td> <td>3</td> </tr> <tr> <td>y</td> <td>-3</td> <td>-1</td> <td>1</td> <td>3</td> <td>5</td> </tr> </tbody> </table>	x	-1	0	1	2	3	y	-3	-1	1	3	5	B2	10	(-1e.e.o.o.)
	x	-1	0	1	2	3											
y	-3	-1	1	3	5												
b)		B1 B1	Correct plotting of points Correct line														

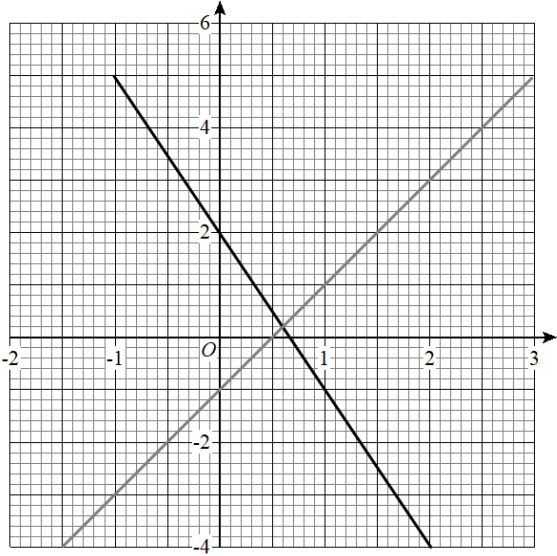
c)		B1		
d)	$m = \frac{-4 - 5}{2 - (-1)} = \frac{-9}{3} = -3$ $c = 2$ <p>Equation of the line is $y = -3x + 2$</p>	B1 B1 B1		Gradient can be read from the straight line.
e)	$x = 0.6, y = 0.2$	B2		1 mark for the x-coordinate and 1 mark for the y-coordinate
11.	$h_B = 144 \div 9.6 = 15 \text{ cm}$ $h_A = \frac{15 \times 100}{120} = 12.5 \text{ cm}$ $w_A = \frac{9.6 \times 100}{120} = 8 \text{ cm}$	B1 M1A1 M1A1	5	
12.	<p>a) $23^{\text{rd}} \text{ term} = 3 \times 23 + 5 = 74$</p> <p>$124^{\text{th}} \text{ term} = 3 \times 124 + 5 = 377$</p> <p>b) $\text{Number of terms} = 124 - 23 + 1 = 102$</p> <p>c) Finding the terms and adding 451 They all add up to the same number</p> <p>d) There are $102 \div 2 = 51$ pairs Sum required = $451 \times 51 = 23\,001$</p>	M1A1 M1A1 M1A1 M2 A1 M1A1 M1A1	13	

13.	a)		B1	8	Correct line BC
	b)		B2		Correct \hat{B} (45°)
	c)		B1		Correct \hat{C} (60°)
14.	a)	$4.5 \times 2 = 9 \text{ km}$	M1 A1	8	
	b)	Total time = 4.5 hrs Average Speed = $9.0 \div 4.5 = 2 \text{ km/h}$	M 1 M1 A1		
	c)	30 minutes	B1		Accept 0.5 hours or half an hour
	d)	Part E Gradient is steeper	B2		