

MATRICULATION AND SECONDARY EDUCATION CERTIFICATE EXAMINATIONS BOARD
UNIVERSITY OF MALTA, MSIDA

SECONDARY EDUCATION CERTIFICATE LEVEL

SPECIMEN PAPER

MAY 2019 SESSION

SUBJECT:	Design and Technology
PAPER NUMBER:	IIB SPECIMEN PAPER
DATE:	2019
TIME:	xx

Answer ALL THREE Sections.

Section A: Core Design and Technology Principles	20 marks
Section B: Design Aspect	25 marks
Section C: Technology Aspect	55 marks

READ carefully the Theme and Situation of this paper: (Reference will be made in all sections)

***Theme:* Cultural Displays**

***Situation:* The idea of celebrating history and culture in our country has led to the development of various museum spaces. These spaces are also a meeting place where people create new ideas. A new Maltese museum requires ideas and designs for various needs it encounters. The museum will have 3 wings, each covering one of these categories: Toy Design, Local Inventions and Luxury Products Design.**

The name of the museum is ‘*CREATE*’ and is aimed at people of all ages and cultures.

Useful Information:

Non-programmable calculators are allowed.

Useful formulae:

***Gear Ratio* :**
$$\frac{\text{Number of Teeth on driven gear}}{\text{Number of Teeth on driver gear}}$$

DO NOT WRITE ABOVE THIS LINE

SECTION A: Core Design & Technology Principles**Read carefully the Situation presented on page 1.****Question 1: Underline the correct answer**

- a. Identify a **keyword/phrase** in the following sentence from the given situation: (underline)

‘A new Maltese museum requires ideas and designs for various needs it encountered’

1 mark

-
- b. Choose which of these lists best describes some of the main areas of **research** you could explore in this situation:

- i. Archaeology, hirographs and papyrus
- ii. Display cabinets, lights and information signs.
- iii. Popular antiques, storage and lights

1 mark

-
- c. Which list best describes ways to gather information about what users want to see in a museum:

- i. Interview historians, news reporters, watch a quiz show.
- ii. Observe people, questionnaires in schools , hire an investigator.
- iii. Questionnaires to different people, observe a similar museum, research online.

1 mark

-
- d. Which of these is **NOT** a way of modelling ideas in a design project.

- i. writing the design brief
- ii. cardboard modelling
- iii. circuit simulation on breadboard

1 mark

-
- e. Which components / materials listed are best suited for an illuminated **outdoor museum sign**:

- i. Mild steel, softwood and smart materials
- ii. Corrugated board, glass and circuits with exposed copper wires
- iii. Stainless steel, thermoplastic sheets and low voltage LED lights.

1 mark

Question 2: Fill in the blanks

a. Mention ONE thermosetting plastic:

_____ **1 mark**

b. Mention ONE mechanism that produces reciprocating motion:

_____ **1 mark**

c. Name ONE material that can be purchased in a pipe standard form:

_____ **1 mark**

d. Mention ONE electronic component that is polarised:

_____ **1 mark**

Question 3: Select the correct answer/s with a tick (✓):

Look carefully at some of the images which were researched for the Situation on page 1.

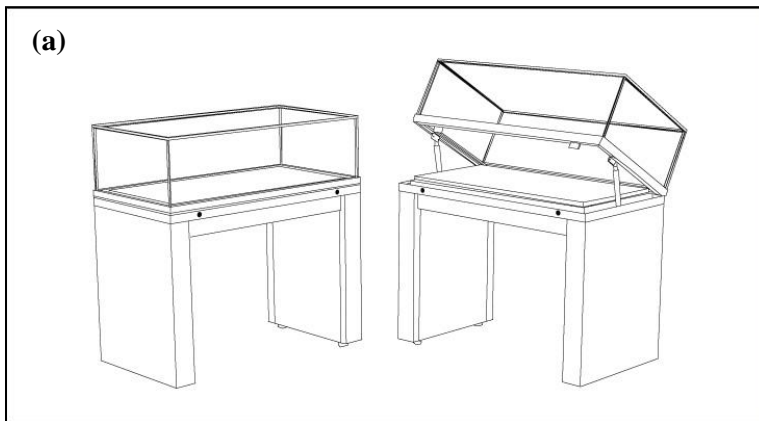
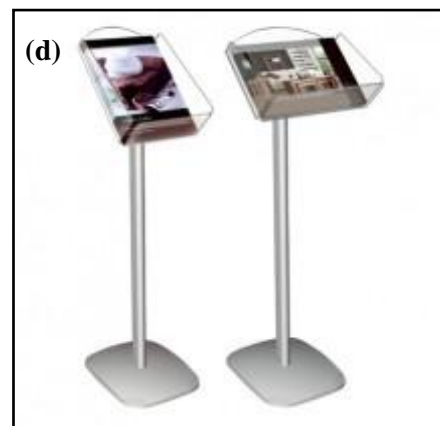

Figure A



DO NOT WRITE ABOVE THIS LINE

a. Which of the image in Figure A shows a revolving display base.

a	b	c	d

1 mark

b. Which image in Figure A shows a hinge mechanism?

a	b	c	d

1 mark

c. Which image in Figure A shows a display case that could best be manufactured as 'one-off' ?

a	b	c	d

1 mark

Question 4: Look carefully at the following Figure B.

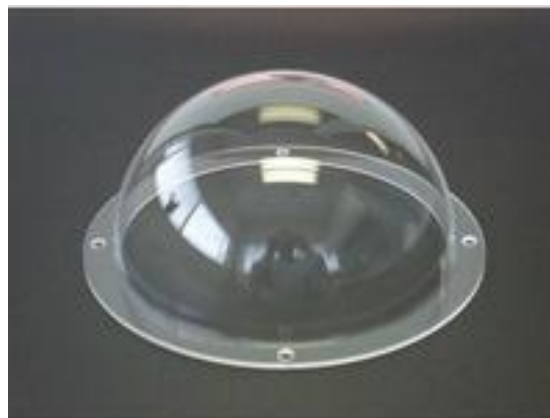

Figure B

a. Which type (name and classification) of polymer could be used to produce the shown hemispheric polymer case?

name: _____ classification: _____ **2 marks**

b. What process could be used to achieve the dome shape shown in Figure B?

_____ **1 mark**





c. What type of structure is the one shown in the Figure B?

_____ **1 mark**

DO NOT WRITE ABOVE THIS LINE

Question 5

a. Fill in the table by naming the components shown.

Component				
Name				

2 marks

b. Draw the schematic symbol for one of the above components. Name again the chosen components.

SYMBOL	
NAME	

1 mark

c. Sketch a 2 x 2 CUBE in 3D isometric view using the grid below:

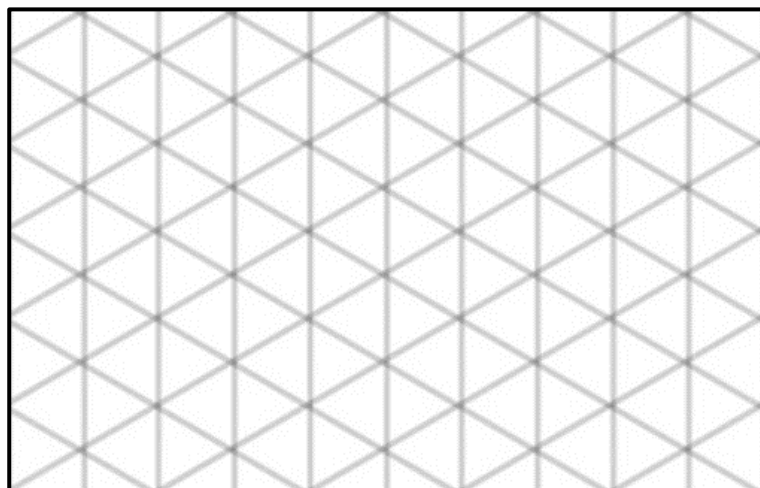

1 mark

DO NOT WRITE ABOVE THIS LINE

SECTION B: DESIGN ASPECT**Read carefully the situation presented on page 1.**

In the following section you will be focusing on the museum's "Toy Design" wing.

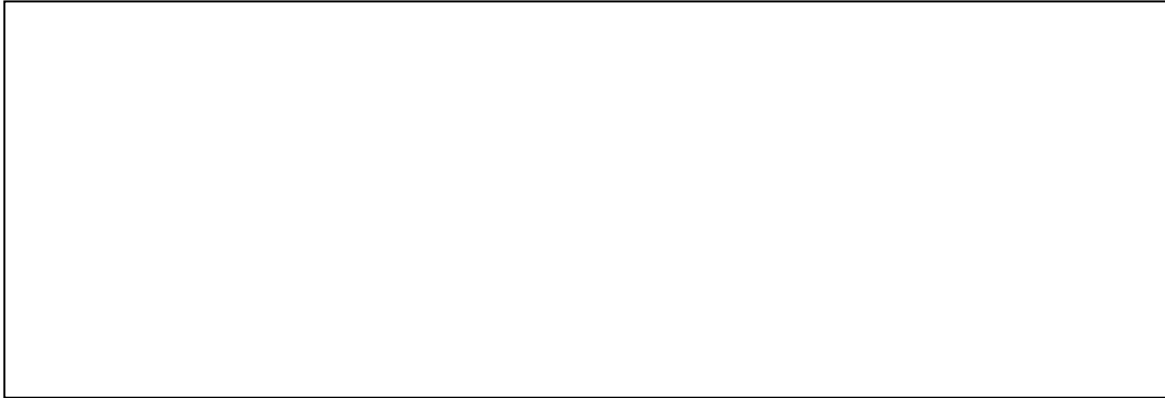
Question 1In the space below, DRAW a sketch of a **3D toy torch**, which could be displayed in the Toy Design museum wing. On your 3D sketch label the switch, lens and one material.**3 marks****Question 2**

a. Complete the DESIGN BRIEF given for the design of a showcase that will display one main attraction item in the Toy Design museum wing. Mention (i) what the item is, (ii) where the display will be used, (iii) at least ONE important feature.

i. Design and make _____

_____.

ii. This needs to be displayed in _____

_____.

iii. The showcase needs to feature _____

_____.

3 marks

DO NOT WRITE ABOVE THIS LINE

b. Read the following specification list which were developed for a similar showcase to the above design brief. Complete the list by suggesting ONE other design specification focusing on lighting.

- 1. *Dimensions and Form factors : The display case needs to have a geometric shape and must not exceed 25cm x 25 cm x 25 cm (LxBxH).*
- 2. *A see-through, clear polymer material shall be used at least for the front side of the display.*
- 3. _____

1 mark

c. Propose and sketch TWO different Ideas for the museum display showcase, in which a Rubik’s cube as shown on the right, can be displayed.

Marks will be awarded for: realistic and effective design, graphic techniques, presentation, annotations, dimensions and innovation. You may divide the space as required or give more prominence to ONE idea compared to the other.

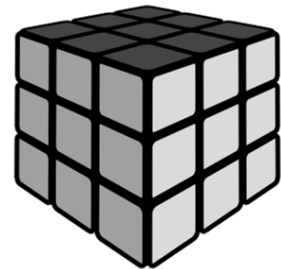

DO NOT WRITE ABOVE THIS LINE

7 marks

Question 3

- a. Write a suitable use for each domain listed in the design of the display cabinet.
The first example has been done for you.

Domain	Use
Textiles	<i>A felt material under the exhibit item for visual contrast.</i>
Wood	
Electronics	
Mechanism	

3 marks

- b. The museum requires every item on display to be illuminated. Describe suitable advantages of this choice to the following stakeholders:

	Advantage
display designer	
museum owners	

2 marks

Question 4

The table below show the number of kids and adults visiting the museum from Monday to Friday.

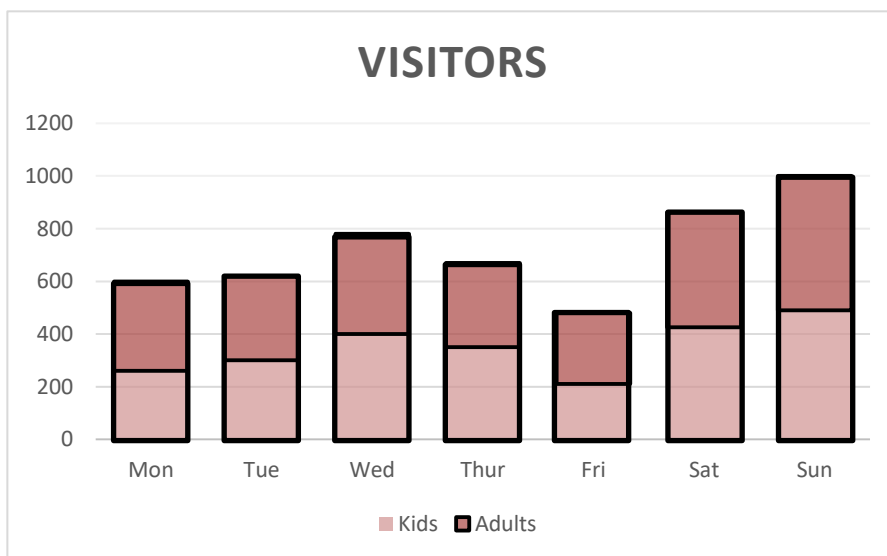

a. Analyse the table above and establish which is the busiest day of the week and the day the museum is least visited.

Busiest day: _____

Day the museum is least visited: _____

2 marks

b. A gift for kids will be distributed every Tuesday. How many gifts would be typically required?

1 mark

c. From the data shown one can conclude that more kids visit the museum on weekends than on week days. Mention TWO factors that contribute to this scenario.

Factor: _____

1 mark

d. During a peer review, the following feedback was collected.

- (a) *“did not help me understand the item being displayed”*
- (b) *“very elegant”*
- (c) *“could be simpler”*
- (d) *“does not appeal at all to adult visitors”*

Identify which of the above comments can be considered as:

i. Positive comment: _____

ii. Constructive criticism: _____

2 marks

SECTION C: TECHNOLOGY ASPECT

Question 1

a. Explain one main characteristic of the following materials.

Aluminium	
PVC	

2 marks

b. Complete the grid below.

Material type	Material Class	Material Name
Metals	Ferrous	
		Aluminium
Woods		Oak
		Pine

4 marks

Question 2

Figure C explains the process of extrusion which is used to make continuous lengths of the same cross-section in metals and plastics.

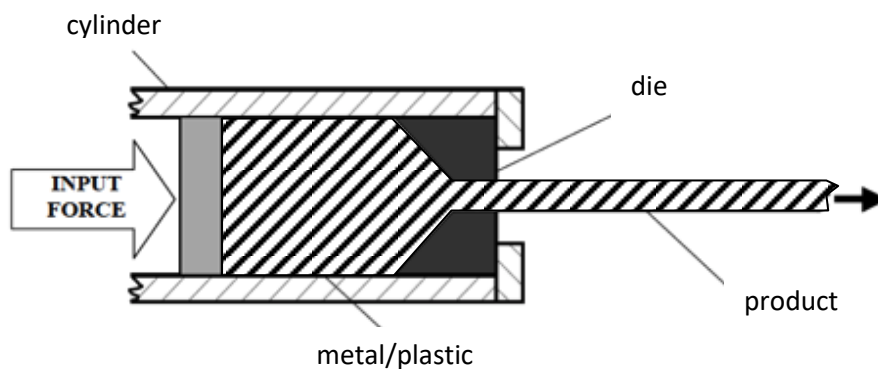

Figure C : Extrusion process

DO NOT WRITE ABOVE THIS LINE

a. Use the following words to fill in the blanks:

● die ● hot ● extrusion ● section

During the _____ process, a material is forced through a _____ to produce a particular cross-_____ profile. The material being pressed can be either _____ or cold.

4 marks

b. State if the following statements are true or false (underline):

i. Hot forming of materials is only suitable for plastics. True / False

ii. Wool is a protein based fibre. True / False

2 marks

c. Give a reason for these procedures done during manufacturing processes:

i. Moulds for vacuum forming need to be tapered:

ii. Material being drilled on a pillar drill needs to be secured:

iii. Before applying a second coat of paint, this should be fully dry and sanded lightly.

3 marks

d. A strip of plastic material needs to be bent to form a corner cover to be installed in the museum passage ways.

Suggest a suitable process to bend plastic along a straight line:

1 mark

Question 3

- a. The system block diagram below shows a light sensor circuit system. On the lines provided below, STATE what each block is called in this system:

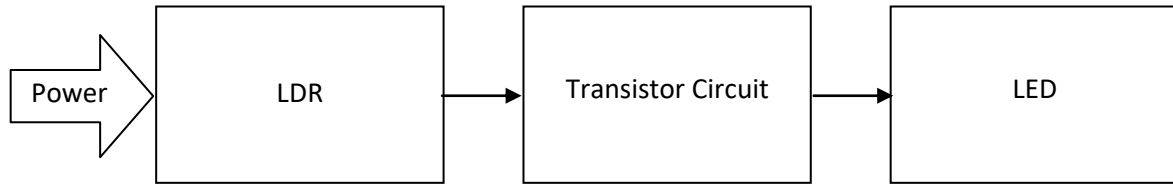

answer here: _____ Process _____

2 marks

- b. Another system design requires a buzzer to sound when a relay is given an input from a user.

Complete the system block diagram below, by filling in the components making up the system explained above (a):

- buzzer
- push-to-make switch
- relay

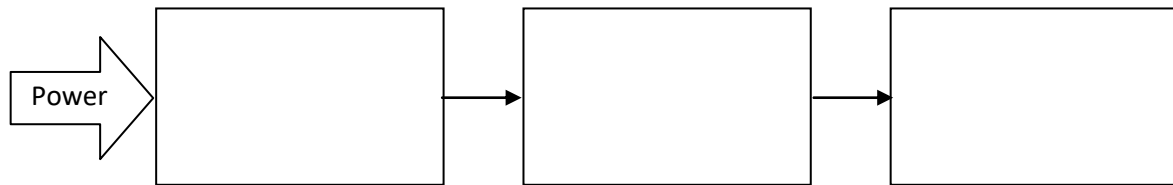

3 marks

Question 4.

- a. Mention an (i) application for the following mechanical system, stating the type of (ii) input and (iii) output movement involved:

	(Toothed) Belt and Pulley system
i. Application	
ii. Input movement	
iii. Output movement	

3 marks

b. Figure D shows a **Gear train**. Gear A = 24 teeth, B = 8 teeth.

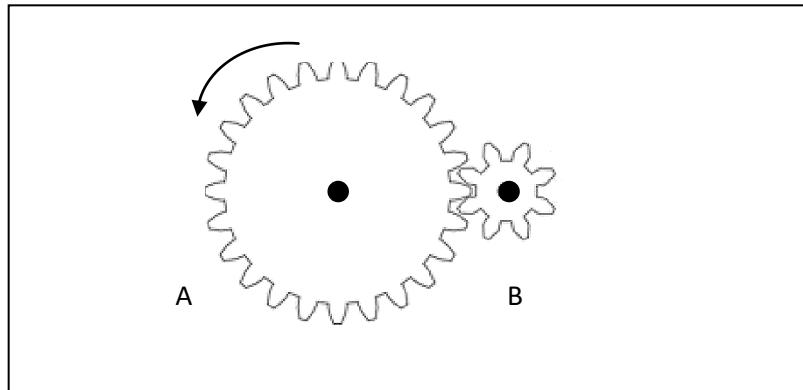

Figure D

i. Given that gear A is the driver of this mechanism, draw the direction of gear B.

1 mark

ii. Calculate the gear ratio between gear A and B.

2 marks

Question 5.

a. Complete the truth table for the AND gate.

A	B	Output Z
1	1	
1	0	
0	1	
0	0	

2 marks

b. Describe the functions of the following components in circuits

(i) Resistor

(ii) LED

2 marks

Question 6

The mechanism shown below in figure E is displayed in the Toy Design museum wing. Visitors turn the cam and observe the motion of the lever.

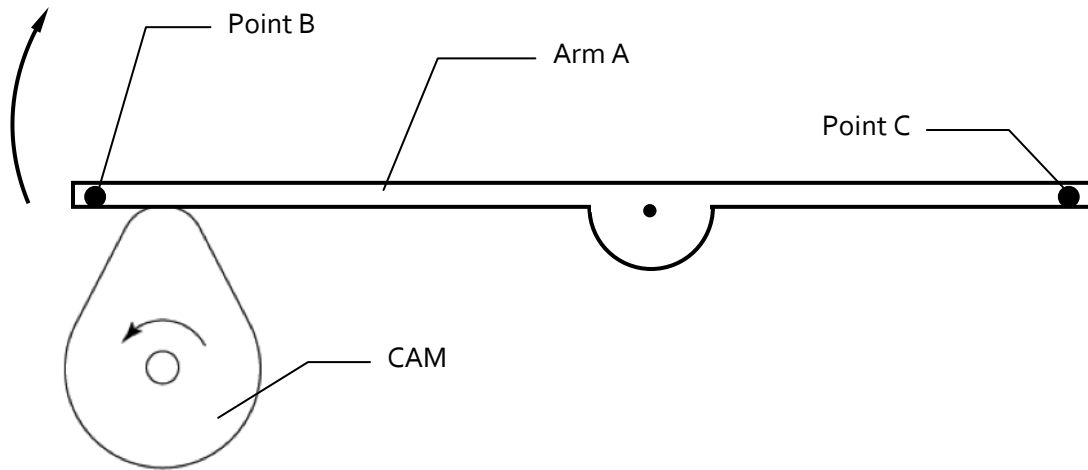

Figure E

a. Arm A is a lever. Name the class of Arm A.

_____ **1 mark**

b. Give the name of the cam profile shown in Figure E.

_____ **1 mark**

c. On Figure E, add an arrow to show the movement of point C when the cam is turned.

1 mark

d. How many times does point B rise when the cam is rotated one revolution?

_____ **1 mark**

Question 7

The circuit in Figure F shows a light sensor alarm for one of the museum showcases. The circuit will trigger a buzzer when there is too much light.

COMPLETE the circuit below by placing (DRAW on figure F) correctly the components shown below:

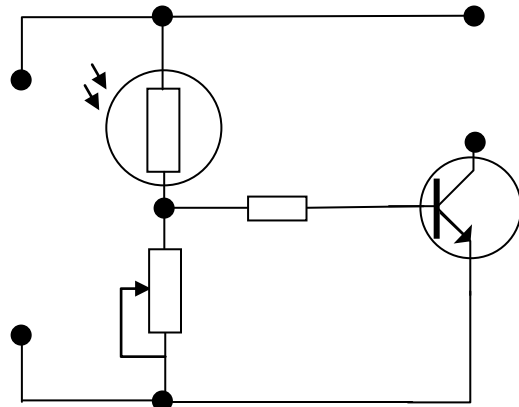
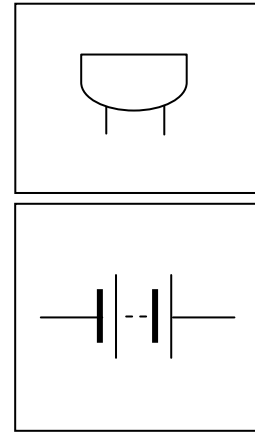

Figure F



4 marks

Question 8

An interactive area in the museum will let preschool kids play with an electronic shape sorter which works with a microcontroller circuit. The divide flashes LEDs when a solid shape is placed correctly on the input switch, in the slot provided. When removed, the switch is off.

- a. The image below shows a circuit which includes a microcontroller. Identify and name the input, the output, the supply and the microcontroller IC. 2 examples have been given.

4 marks

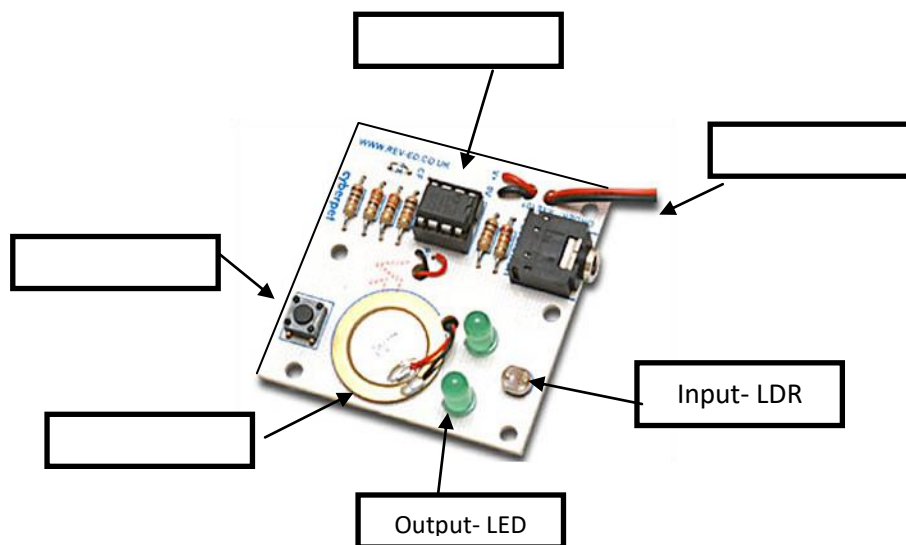

b. Figure G shows a simple programme in a flow chart format.

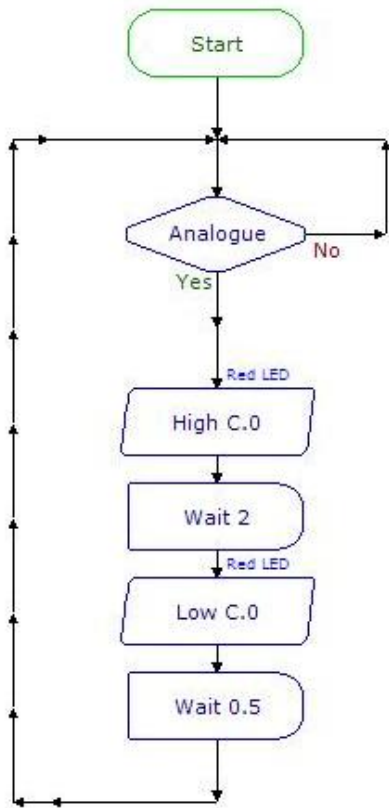

Figure G

Note: code C.O. on the flow chart refers to 1 output pin in the circuit. Other units are standard time units in seconds.

i. What is the output in this simple programme?

ii. How long would the Red LED stays ON when the input is high? _____

iii. What does this symbol mean?

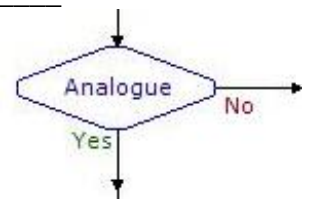

iv. What happens when you keep pressing the analogue input? _____

4 mark

c. A flashing LED in a simple circuit can also provide the same blinking effect as the circuit above. What advantage is gained over a flashing LED circuit with the microcontroller circuit shown above.

2 marks

DO NOT WRITE ABOVE THIS LINE

Question 9

The Museum's management needs a new logo for the museum to help send the message to prospective visitors that their exhibit focuses on innovation, ideas and design.

- a. In the space provided below, sketch TWO logo ideas, including the name of the museum, "CREATE". Use of colours is recommended.

Sketch 1



Sketch 2

**4 marks**

DO NOT WRITE ABOVE THIS LINE

Figure H shows a brochure holder, which is usually placed on the Museum’s counter.

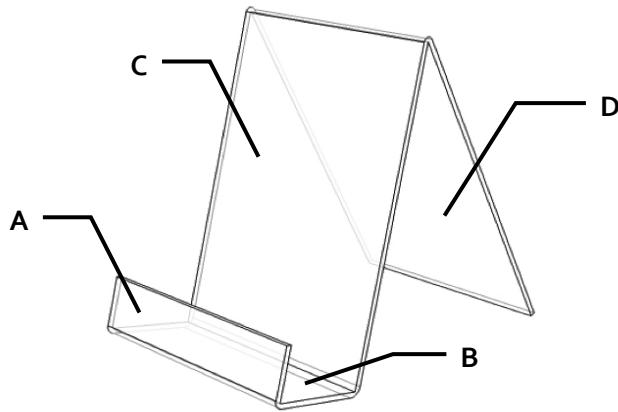
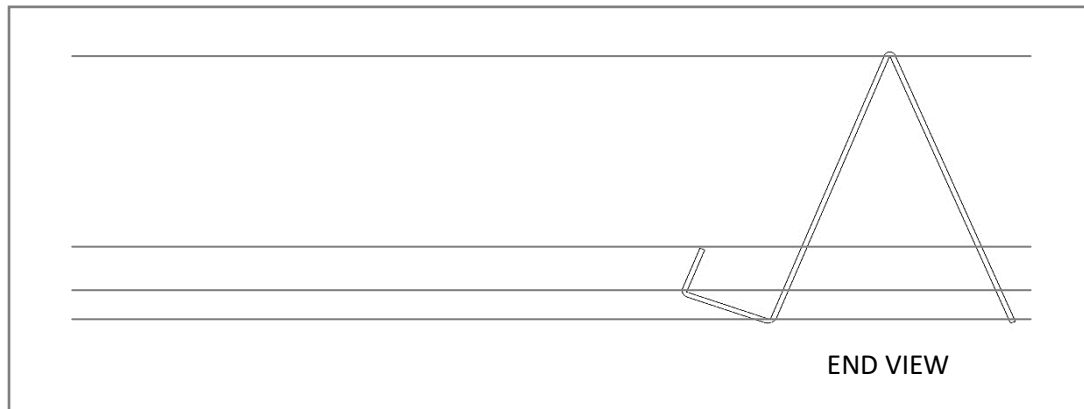

Figure H

b. From the given end view, draw freehand the front view of the brochure holder.



2 marks

c. From the options below select the appropriate net needed, to be produced the brochure holder shown in figure H.

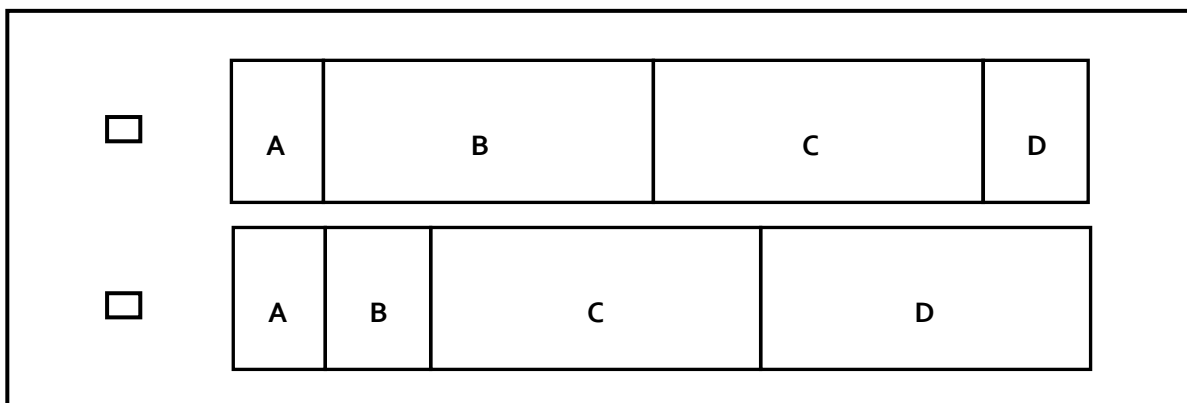

2 marks